

Halsey Solar RRFB Pedestrian Crossings



City of Wood Village & Multnomah County

Background

- City of Wood Village received a grant for a portion of the design and installation of RRFB crosswalks
- The locations of these RRFB's are included in the Main Streets on Halsey Plan which is a Strategic Economic plan that was a collaboration between the cities of Fairview, Wood Village, and Troutdale and Metro and community stakeholders.
- City of Wood Village requested the County to design 4 RRFB crossings on Halsey St
- City of Wood Village is covering the cost of design and construction
- The City of Wood Village is managing the construction contract
- The County will be owning and maintaining these RRFB's

Locations

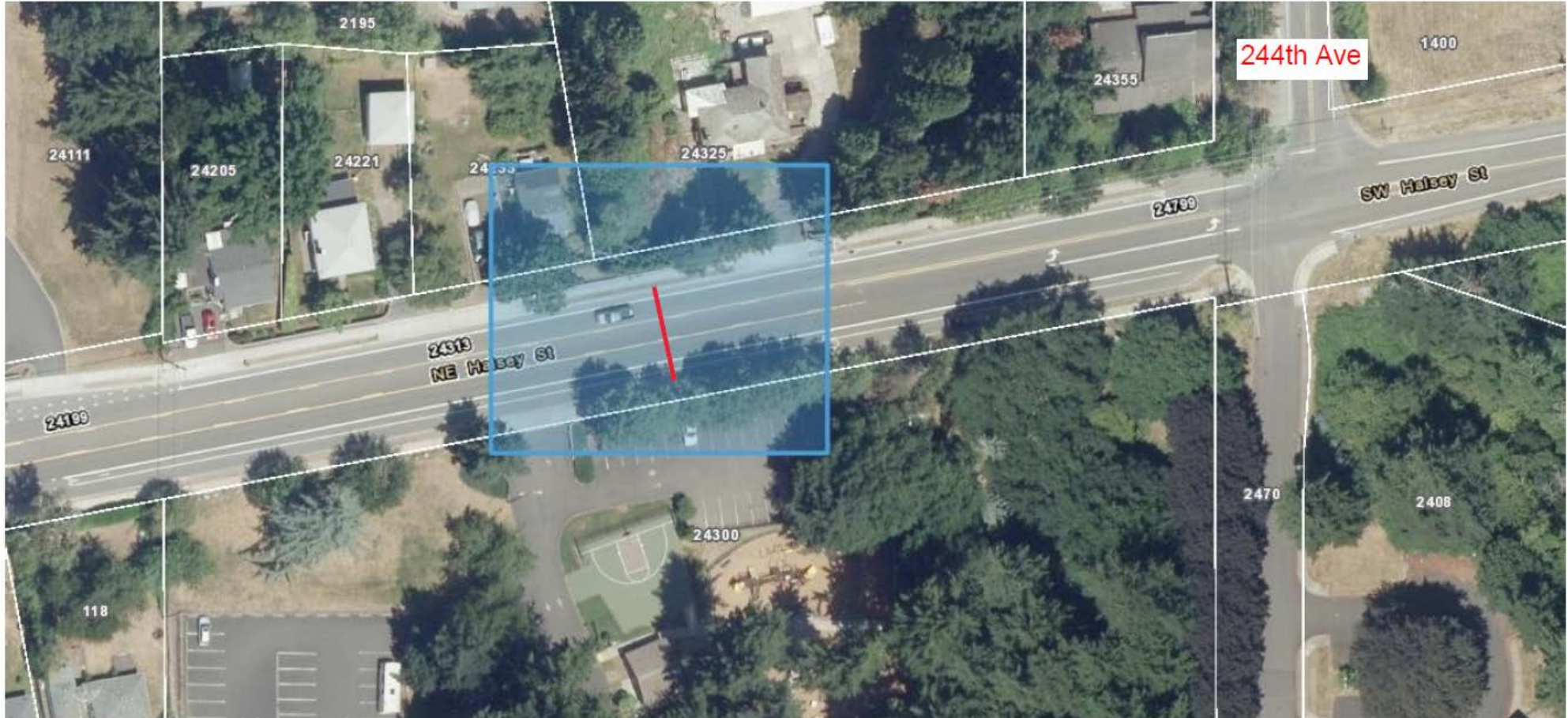

Location 1 - Near 244th intersection – in between the park entrance and the west side of the turn lane at 244th

Locations



Location 2 – east side of the T intersection at 240th

Locations



Location 3 – Between the Best Western and the business park. Approximate address 23424 NE Halsey St.

Locations



Location 4 – Depending on existing conditions, one of these 2 locations near the limits of the City of Wood Village and City of Fairview. Approximate address 23139 NE Halsey St.

What's next?

- Multnomah County is currently working on the design
 - New ADA ramps
 - Possible refuge islands
 - Solar RRFB's
 - Crosswalk Striping

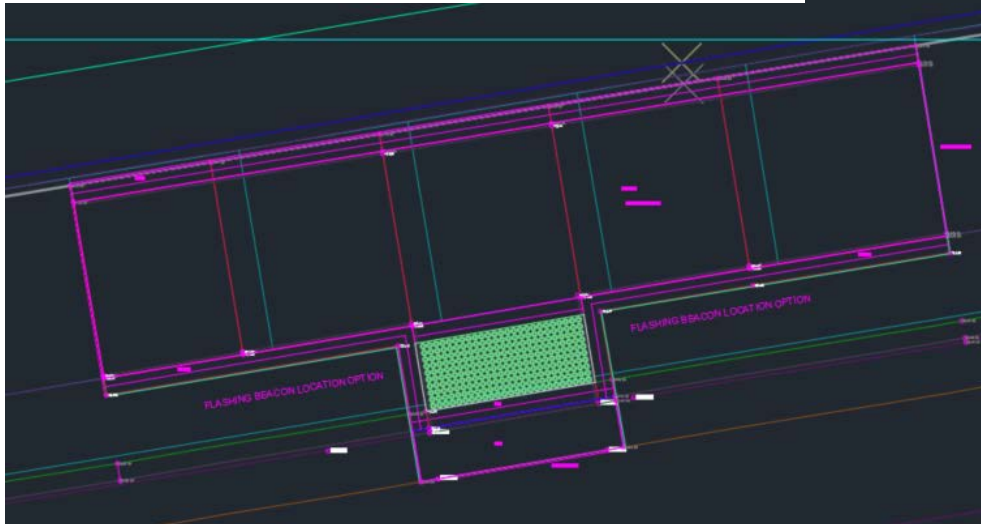
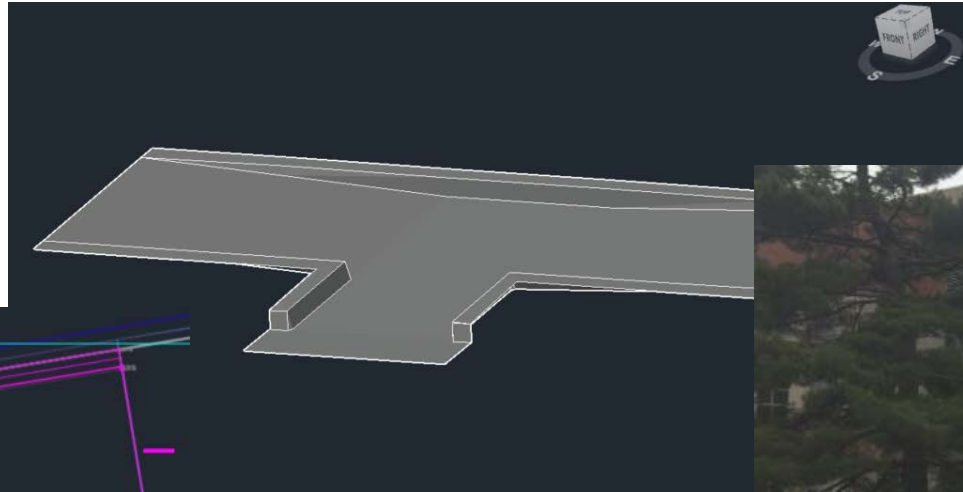

- The City and the County are hoping to get these RRFB crosswalks installed this year

Questions?

