



Technical Memorandum

Subject: Filtration Facility Site and Lighting Plans

PWB Project #s: W02229

Date: March 15, 2023

To: Lyda Hakes, P.E., Project Manager
Portland Water Bureau

From: Mark Graham, P.E., Project Manager
Stantec

Prepared by: Jason Hirst, Oregon #LA0821
NNA Landscape Architecture LLC



in association with

and other firms

Rafael Gaeta, P.E.
Emerio Design

Reviewed by: Mark Graham, P.E.
Stantec

The two sets of drawings attached to this technical memorandum (TM) were prepared in support of the City of Portland Water Bureau’s Bull Run Treatment Facilities’ land use applications in Multnomah County. These drawings reflect the current status of the Filtration Facility design, which is approximately 90% complete as of the date of this TM. The drawings have been prepared and compiled for the specific purpose of addressing conformance to Multnomah County land use requirements as expressed in the Multnomah County Code.

The contents of each set of drawings are listed in the tables below.

Table 1. Site Plan Drawings	
Drawing Number	Drawing Name
00-LU-101	Cover Sheet
00-LU-102	Vicinity and Zoning Map
00-LU-301	Existing Conditions Plan
00-LU-302	Proposed Conditions Site Plan
00-LU-303	Utility Plan
00-LU-304	Grading Plan
00-LU-305	Facility Circulation Map
00-LU-306	Landscape Plan
00-LU-307	Stormwater Management Plan - Filtration Facility
00-LU-400	Facility Enlargement 1
00-LU-401	Facility Enlargement 2
00-LU-402	Tower Area Enlargement
00-LU-403	Signs
00-LU-404	Stormwater Planting
00-LU-405	Roadway Typical Section
00-LU-406	Roadway Typical Section - 2
00-LU-407	Pond Section Details
00-LU-408	Flow Control Maintenance Hole Details
00-LU-409	Plant List
00-LU-410	Plant Layouts
GEN-C-920	Storm Details
GEN-C-923	Storm Details
00-LU-101	Cover Sheet
00-LU-102	Vicinity and Zoning Map
00-LU-301	Existing Conditions Plan
00-LU-302	Proposed Conditions Site Plan

Table 2. Lighting Plan Drawings	
Drawing Number	Drawing Name
00-E-322	Site Lighting Key Plan
00-E-323	Lighting & Receptacle Plan - Grid 1
00-E-324	Lighting & Receptacle Plan - Grid 2
00-E-325	Lighting & Receptacle Plan - Grid 3
00-E-326	Lighting & Receptacle Plan - Grid 4
00-E-327	Lighting & Receptacle Plan - Grid 5
00-E-328	Lighting & Receptacle Plan - Grid 6
00-E-329	Lighting & Receptacle Plan - Grid 7
00-E-330	Lighting & Receptacle Plan - Grid 8
00-E-331	Lighting & Receptacle Plan - Grid 9
00-E-332	Lighting & Receptacle Plan - Grid 10
00-E-333	Lighting & Receptacle Plan - Grid 11
GEN-E-140	Lighting Schedule - 1
GEN-E-141	Lighting Schedule - 2
GEN-E-142	Lighting Schedule - 3

Attachment A: Site Plans

Filtration Facility Land Use Submittal

Drawing Index

- LU-101 Cover Sheet
- LU-102 Vicinity and Zoning Map
- LU-301 Existing Conditions
- LU-302 Proposed Conditions Site Plan
- LU-303 Overall Utilities Plan
- LU-304 Overall Grading and Paving
- LU-305 Parking, Loading and Circulation Plan
- LU-306 Landscape Plan
- LU-307 Stormwater Management Plan
- LU-400 Facility Enlargement 1 - Parking and Loading
- LU-401 Facility Enlargement 2 - Parking and Loading
- LU-402 Tower Area Enlargement
- LU-403 Signage Elevations
- LU-404 Stormwater Planting
- LU-405 Roadway Typical Sections
- LU-406 Roadway Typical Sections 2
- LU-407 Pond Section Details
- LU-408 Flow Control Manhole Details
- GEN-C-920 Storm Details 1
- GEN-C-923 Storm Details 4

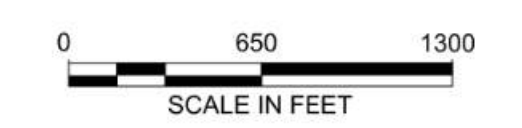
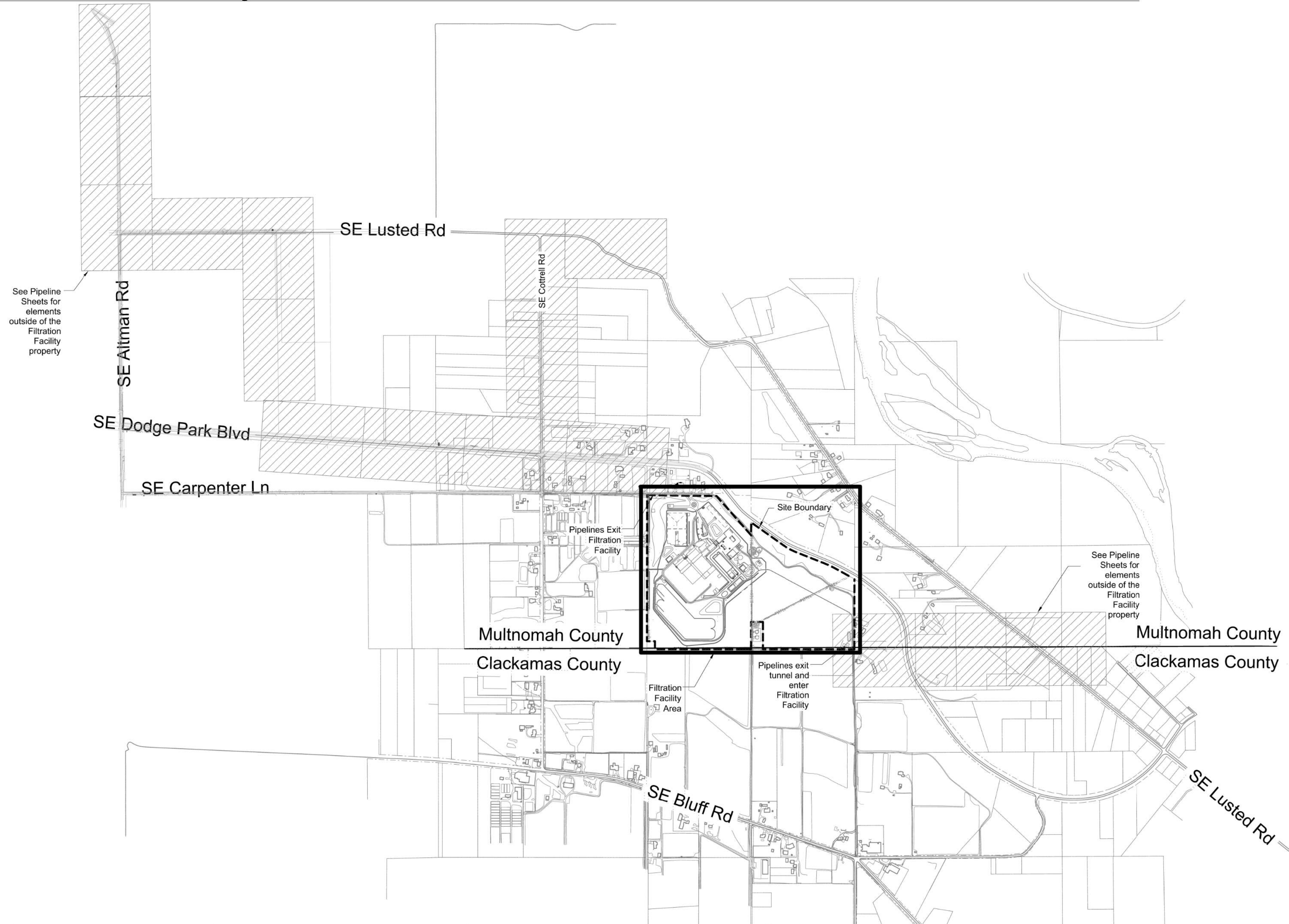

File: W02229-FF-00-LU-101.dgn Model: Gen-C-302 ColorTable: user attached from dialog DesignScript: PWB_PenTable.pen PlotScale: 1:0.0833333 Plot Date: 30-AUG-2022 11:36 User: JASON

No	Date	Description	Appd
C	09/2022	Second Intermediate Design and BCOE Review - 90% Submittal	MRG
B	01/2022	Intermediate Design - 60% Submittal	MRG
A	07/2021	Initial Design - 30% Submittal	MRG
Revision			
Survey			



Designed By	Program Mgr	DWP
Drawn By	Const Mgr	TG
Checked By	Const Supvr	RW
Project Mgr	Date	MRG 09/02/22

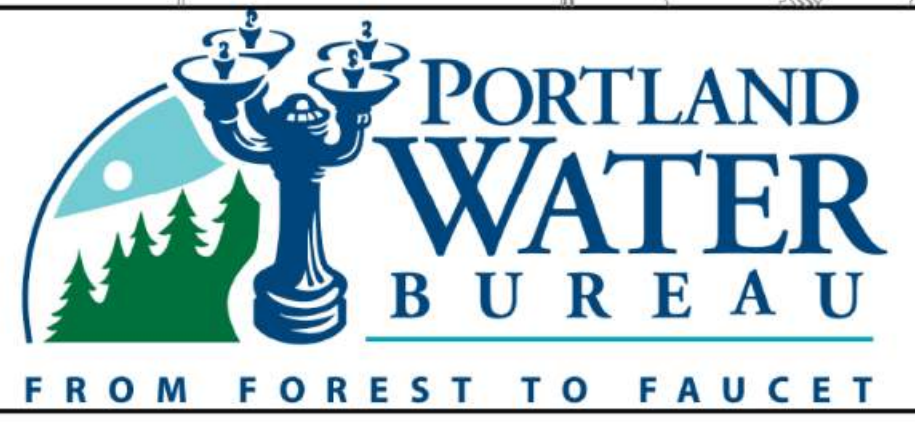

David W. Peters, Engineering Manager, PE No 16683



Bull Run Filtration Facility
Land Use Plans
Cover Sheet

Exhibit A.212.a

SAP Project No	W02229
1/4 Section	
Sheet No	00-LU-101
	1 of 18

Plot Date: 6-SEP-2022 14:46 User: JASON File: W02229-FF-00-LU-102.dgn Model: Layout1 ColorTable: user attached from dialog DesignScript: PWB_PenTable.pen PlotScale: 1:0.0833333

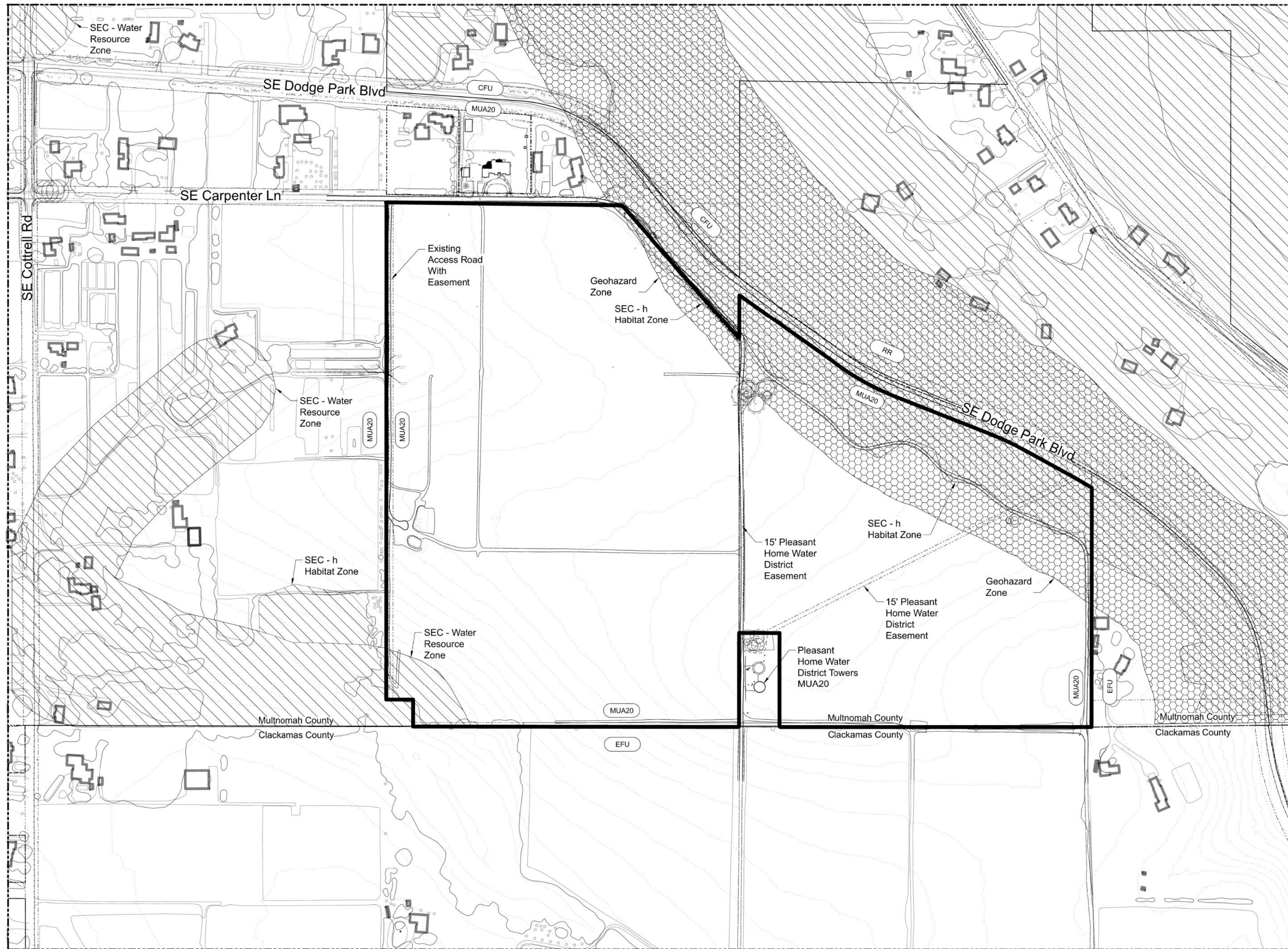

PLAN
SCALE: 1" = 200'-0"

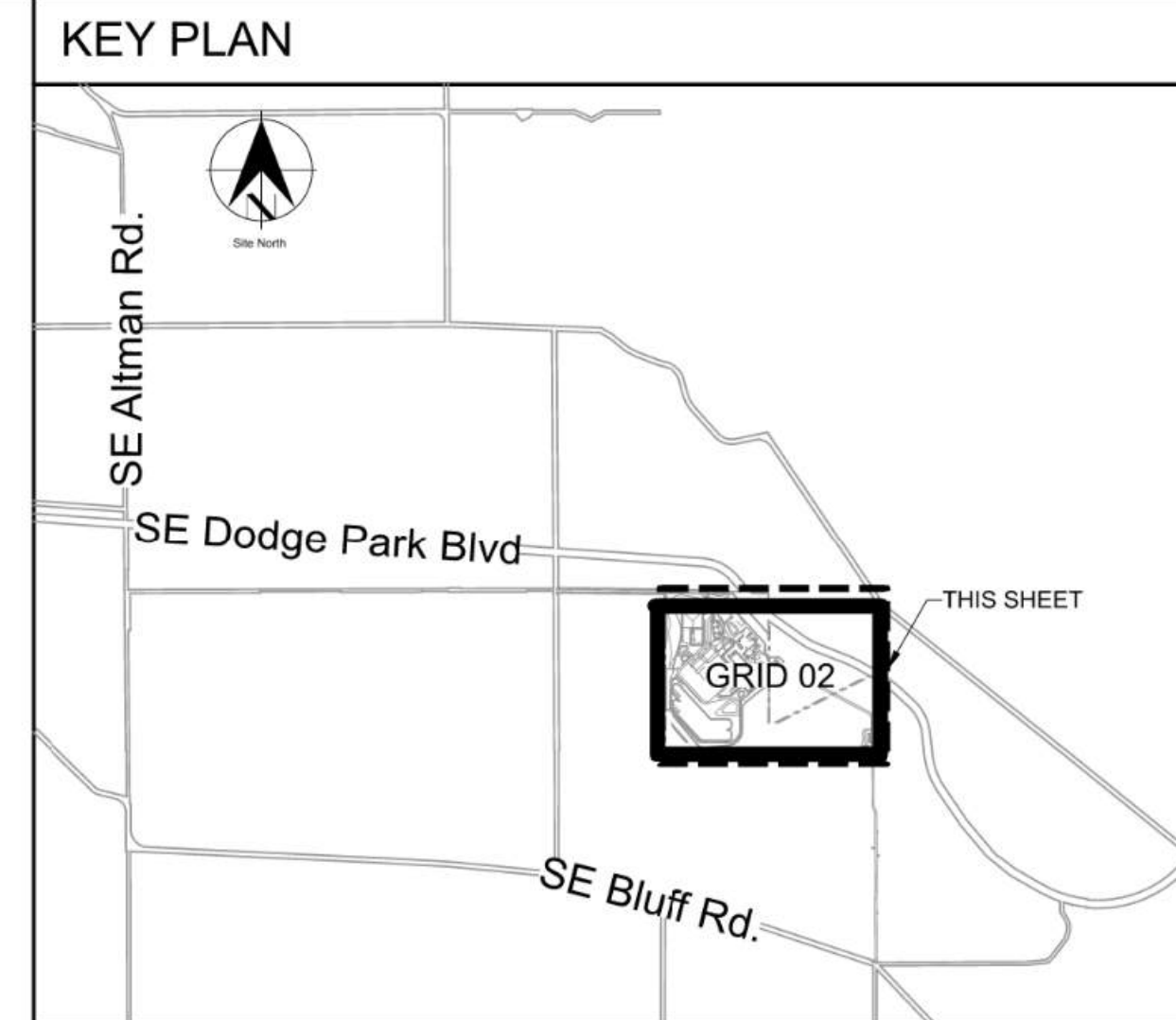

General Sheet Notes
1. No development or construction activity proposed within SEC zones on Filtration Site.

- Legend
- Geohazard Zone
 - Significant Environmental Concern (SEC) Zones - See Labels
 - Lot Line
 - ROW Line
 - Topographic Lines - 5' Interval
 - Structure
 - Vegetation Edge
 - MUA20 Zone
 - EFU Zone
 - CFU Zone
 - RR Zone

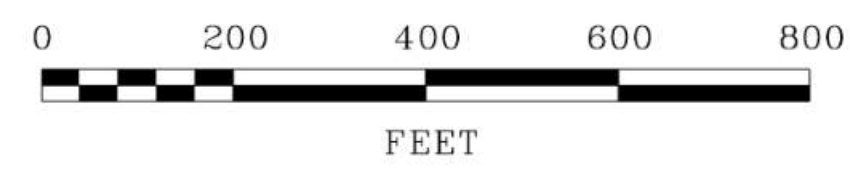

REGISTERED
0821
Jason First
OREGON
02/20/2014
LANDSCAPE ARCHITECT
Expires: 02/27/2023



No	Date	Description	Appd
C	09/2022	Second Intermediate Design and BCOE Review - 90% Submittal	MRG
B	01/2022	Intermediate Design - 60% Submittal	MRG
A	07/2021	Initial Design - 30% Submittal	MRG
No			



Designed By	NNA	Program Mgr	MRG
Drawn By	NNA	Const Mgr	MRG
Checked By	NNA	Const Supvr	MRG
Project Mgr	MRG	Date	09/02/22

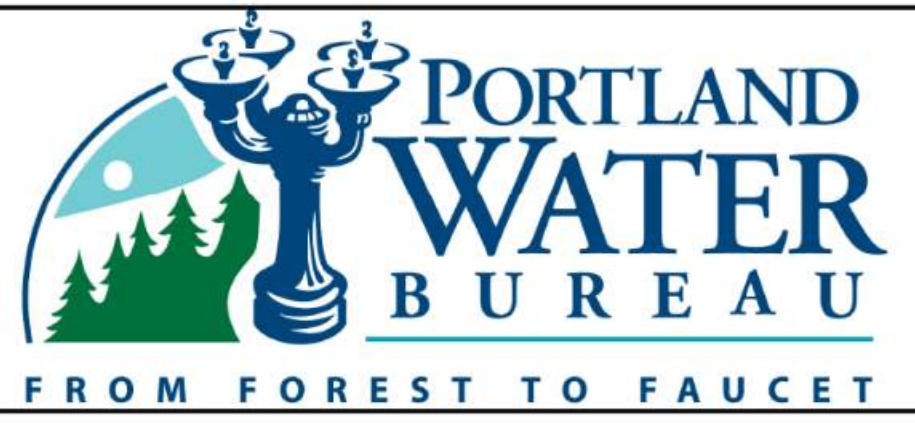

David W. Peters, Engineering Manager, PE No 16683 Date



Bull Run Filtration Facility
Land Use Plans
Vicinity and Zoning Map

Exhibit A.212.b

SAP Project No	W02229
1/4 Section	-
Sheet No	00-LU-102
	2 of 18

File: W02229-F0-LU-301.dgn Model: Layout1 ColorTable: user attached from dialog DesignScript: PWB_PenTable.pen PlotScale: 1:0.0833333
 Plot Date: 30-AUG-2022 09:38 User: JASON

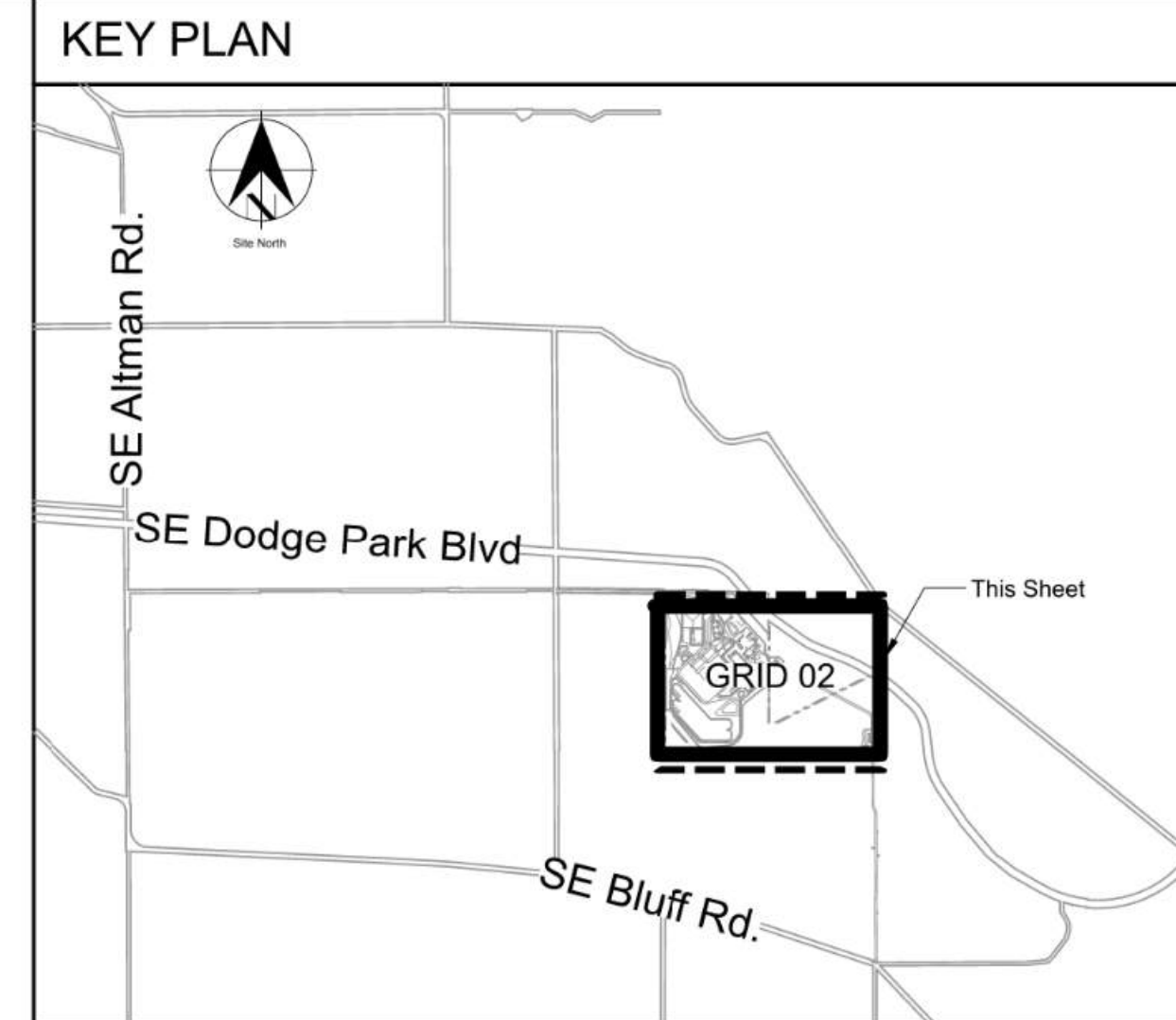
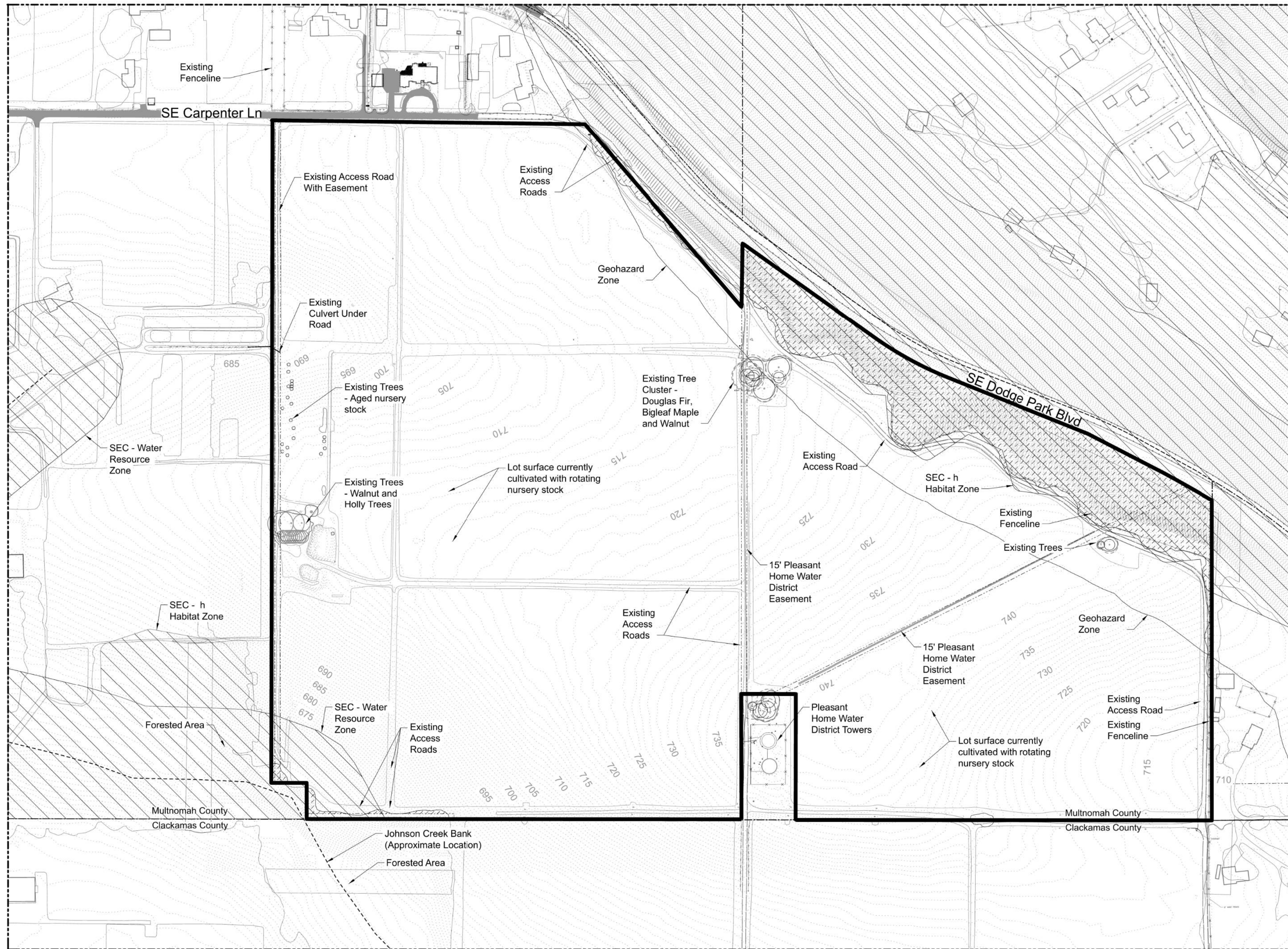

General Sheet Notes

1. Site is currently cultivated as nursery stock.

Legend

- See Labels
 - Lot Line
 - ROW Line
 - Topographic Lines - 5' Interval
 - Structure
 - Existing Fencing
 - Edge of Existing Vegetation Areas
 - Forested Area within Site Boundary
- Zones**

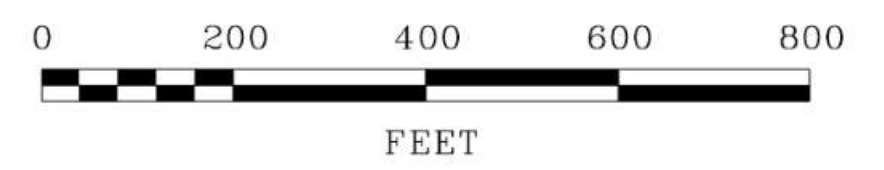

PLAN
SCALE: 1" = 200'-0"

No	Date	Description	Appd
C	09/2022	Second Intermediate Design and BCOE Review - 90% Submittal	MRG
B	01/2022	Intermediate Design - 60% Submittal	MRG
A	07/2021	Initial Design - 30% Submittal	MRG
No			



Designed By	NNA	Program Mgr	MRG
Drawn By	NNA	Const Mgr	MRG
Checked By	NNA	Const Supvr	MRG
Project Mgr	MRG	Date	09/02/22



David W. Peters, Engineering Manager, PE No 16683 Date



Bull Run Filtration Facility
Land Use Plans
Existing Conditions Plan

Exhibit A.212.c

SAP Project No	W02229
1/4 Section	-
Sheet No	00-LU-301
	3 of 18

Plot Date: 30-AUG-2022 09:55 User: JASON File: W02229-FF-00-LU-302.dgn Model: Layout1 ColorTable: user attached from dialog DesignScript: PWB_PenTable.pen PlotScale: 1:0.08333333

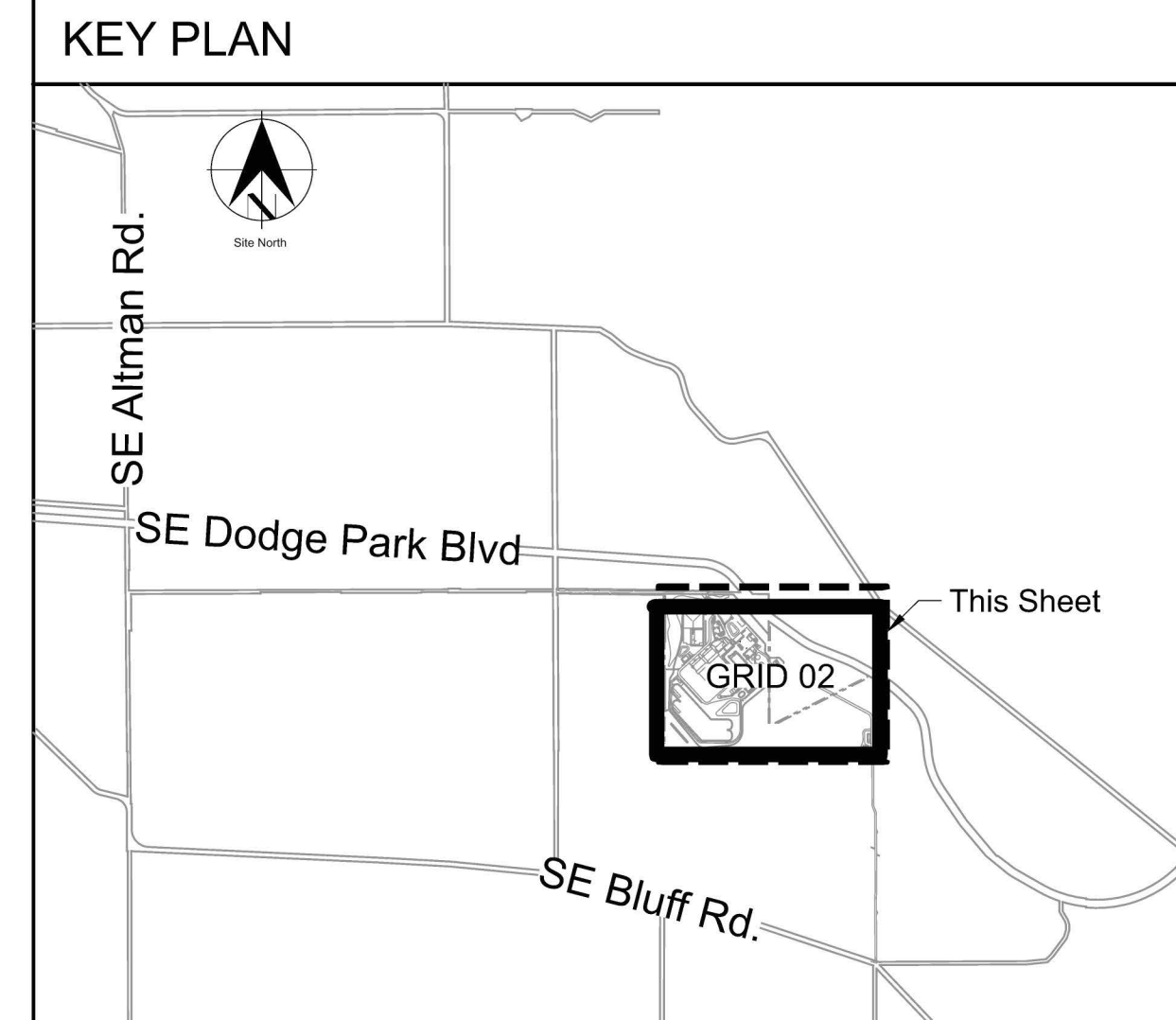
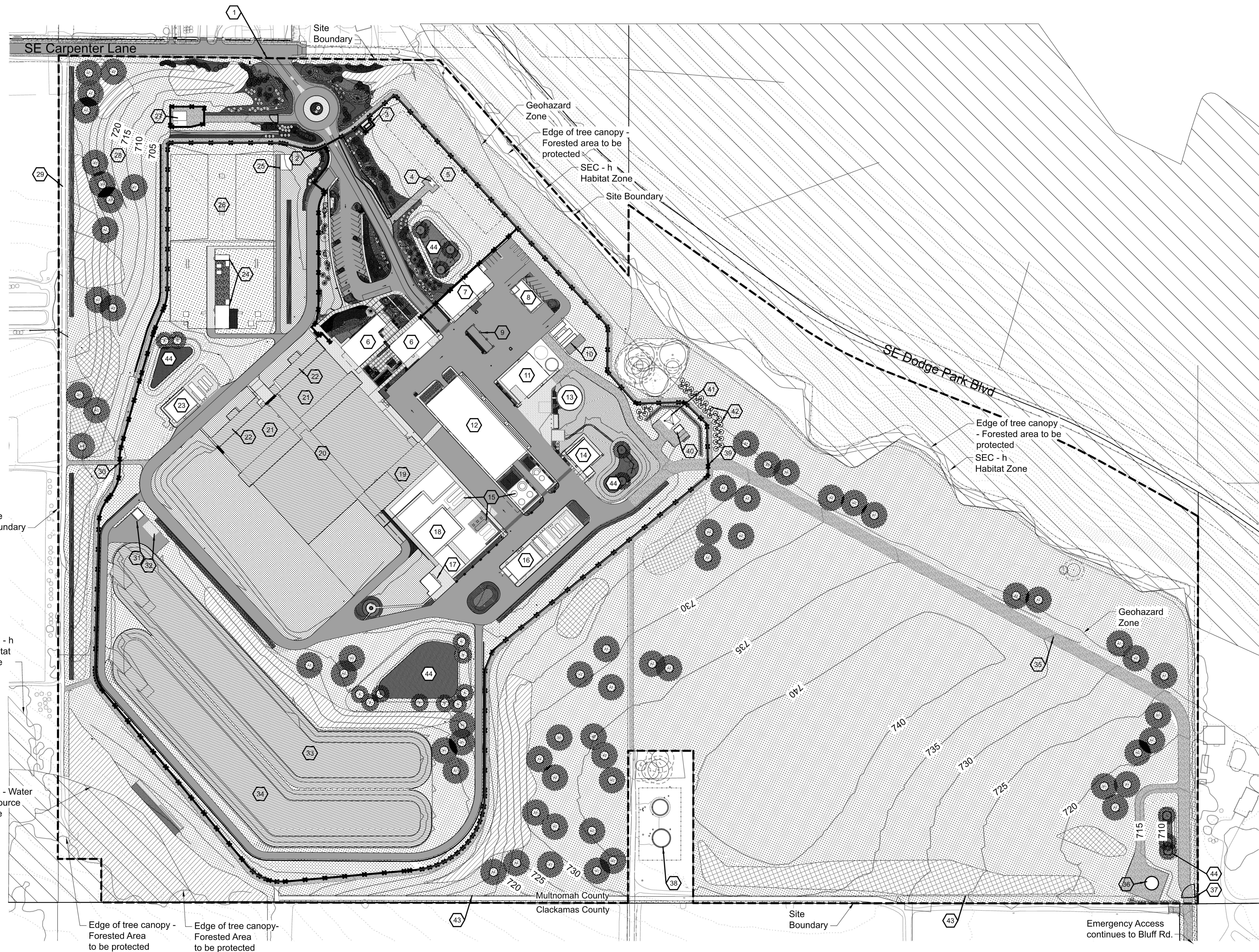

- Sheet Keynotes**
- | | |
|---|---|
| 1. Carpenter Lane Entry | 24. Pumpstation |
| 2. Main Facility Entry Gates | 25. Fire Pumpstation Enclosure |
| 3. North PGE Electrical Cutout | 26. Finish Water Clearwell (Below Grade) |
| 4. Septic Structure (At Grade) | 27. Pleasant Home Pumpstation (Non-PWB) |
| 5. Septic Drainage Field | 28. West Screening Berm |
| 6. Administration Building | 29. Easement on PWB Property (To Remain) |
| 7. Maintenance Building | 30. West Gate |
| 8. General Storage Building | 31. Electrical Building |
| 9. Refuse / Recycling Storage Shed | 32. Overflow Pumpstation (At-Grade) |
| 10. Pilot (CONEX) | 33. North Overflow Basin |
| 11. Mechanical Dewatering / Solids | 34. South Overflow Basin |
| 12. Chemical Building | 35. Emergency Access Route |
| 13. Gravity Thickeners | 36. Raw Water Pipeline Cover (At-Grade) |
| 14. Washwater Clarification | 37. Manual Bar Gate with Knox Box |
| 15. Chemical Storage Tanks | 38. Pleasant Home Water Towers (Off-Site) |
| 16. Main Electric Complex | 39. East Gate |
| 17. Raw Water Inlet Structure | 40. Communication Tower Accessory Building |
| 18. Ozone Building (Not In Use) | 41. Communication Tower |
| 19. Ozone Injection / Flash Mix | 42. Tower Screen Planting
(Native Evergreen Hedge and
25' Min. Tree Buffer) |
| 20. Flocculation / Sedimentation Basin | 43. Agricultural Style Fence |
| 21. Filtration Basin | 44. Detention Ponds |
| 22. Waste Washwater Equalization Basins | |
| 23. North Electric Complex | |

- General Sheet Notes**
- Site is Zoned MUA-20
 - No development or construction activity proposed within SEC zones on Filtration Site. Revegetation of existing agricultural land to be performed with hand tools only. Native plant species only allowed for revegetation in these zones
 - No development or construction activity proposed within Geohazard Area on Filtration Site.

- Legend**
- | | |
|---------------------------|--|
| Asphalt Paving | Swale Planting |
| Concrete Paving | Stormwater Planting |
| Gravel Paving | Screen Mix: Forested Planting |
| Basins | Screen Mix: Shrubby Planting |
| Fenceline | Tree / Shrub Planting Clusters |
| Native Grass / Forb Mixes | Proposed Trees - Deciduous and Evergreen |
| | Landscape Bed - Shrubs, Groundcover, Mulch |
| | Existing tree to remain |

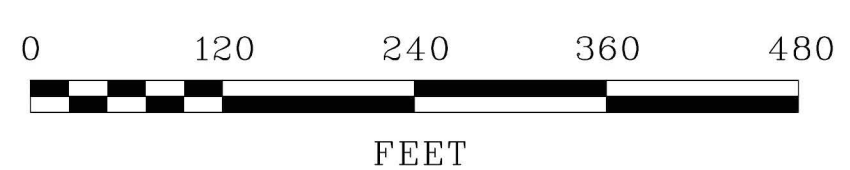

PLAN
SCALE: 1" = 120'-0"

No	Date	Description	Appd
D	12/2022	Response to Completeness Review	MRG
C	09/2022	Second Intermediate Design and BCOE Review - 90% Submittal	MRG
B	01/2022	Intermediate Design - 60% Submittal	MRG
A	07/2021	Initial Design - 30% Submittal	MRG
No			



Designed By	NINA	Program Mgr	MRG
Drawn By	NINA	Const Mgr	MRG
Checked By	NINA	Const Supvr	MRG
Project Mgr	MRG	Date	09/02/22



David W. Peters, Engineering Manager, PE No 16683 Date



Bull Run Filtration Facility
Land Use Plans
Proposed Conditions Site Plan

Exhibit A.212.d

SAP Project No	W02229
1/4 Section	-
Revised Sheet No	00-LU-302
	4 of 18

Plot Date: 19-SEP-2022 20:04 User: stanpw11-pw-svc File: W02229_FF_004-LU-303.dgn Model: 00-LU-303 ColorTable: bw_jPlot.ctb DesignScript: PWB_PenTable.pen PlotScale: 0.0833333:1

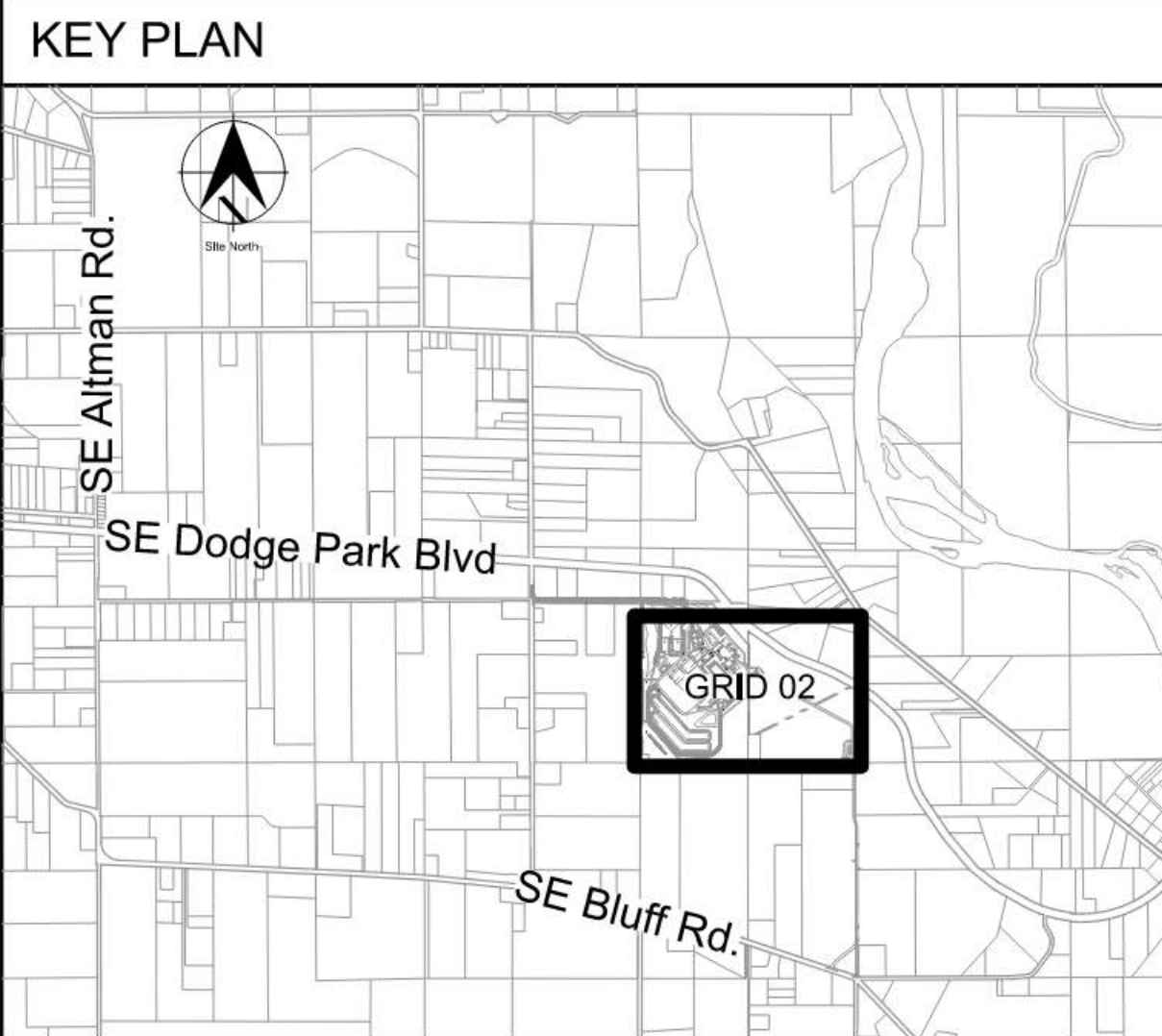
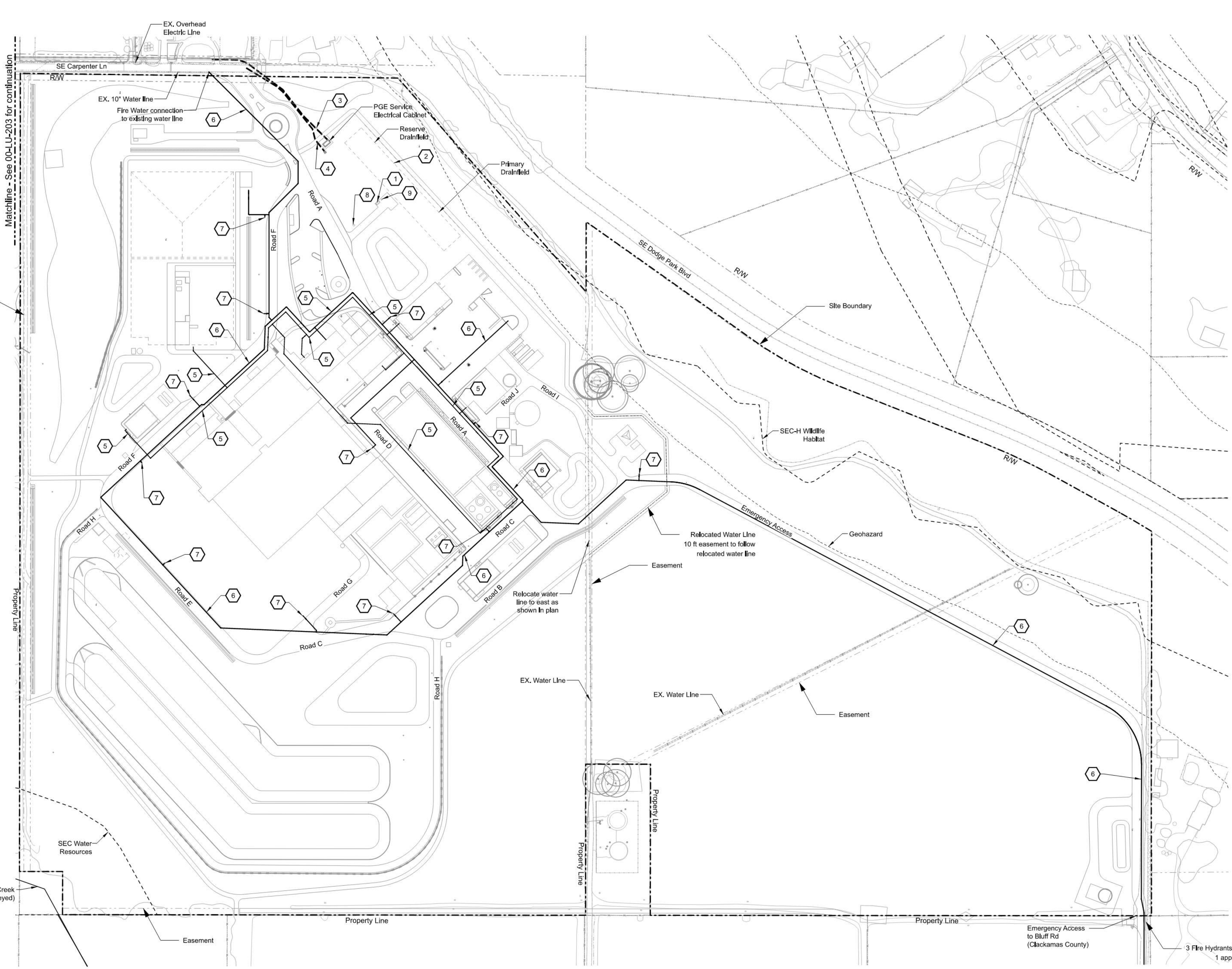

- General Sheet Notes**
- All existing utilities to remain in place and protected during construction.
 - See Sheet 00-LU-307 for Stormwater features and pipes.
 - Potable Water and Utility Water Lines come from Clearwell (on-site finished water).

- Sheet Keynotes**
- Septic Tank
 - Septic Drainfield
 - Electrical Duct bank (underground)
 - Fiber Optic Line (underground)
 - Potable Water
 - Fire Water
 - Fire Hydrant
 - Septic Sewer Lift Station
 - Septic Dosing Tank

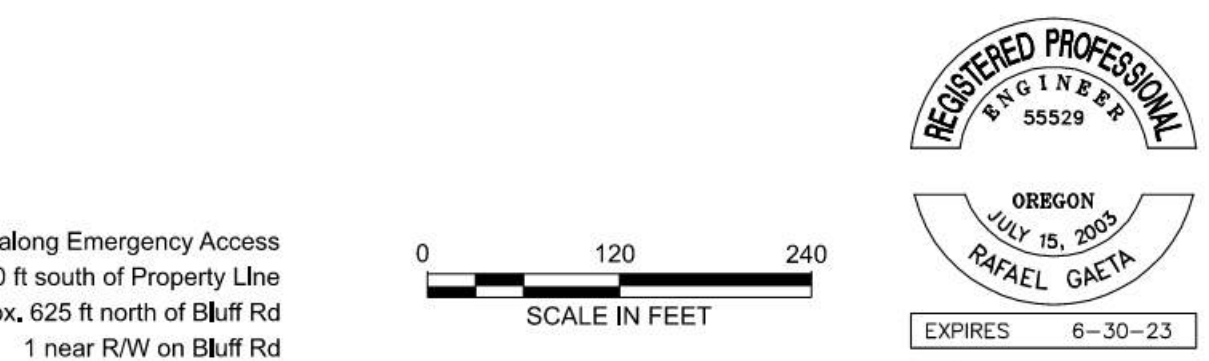
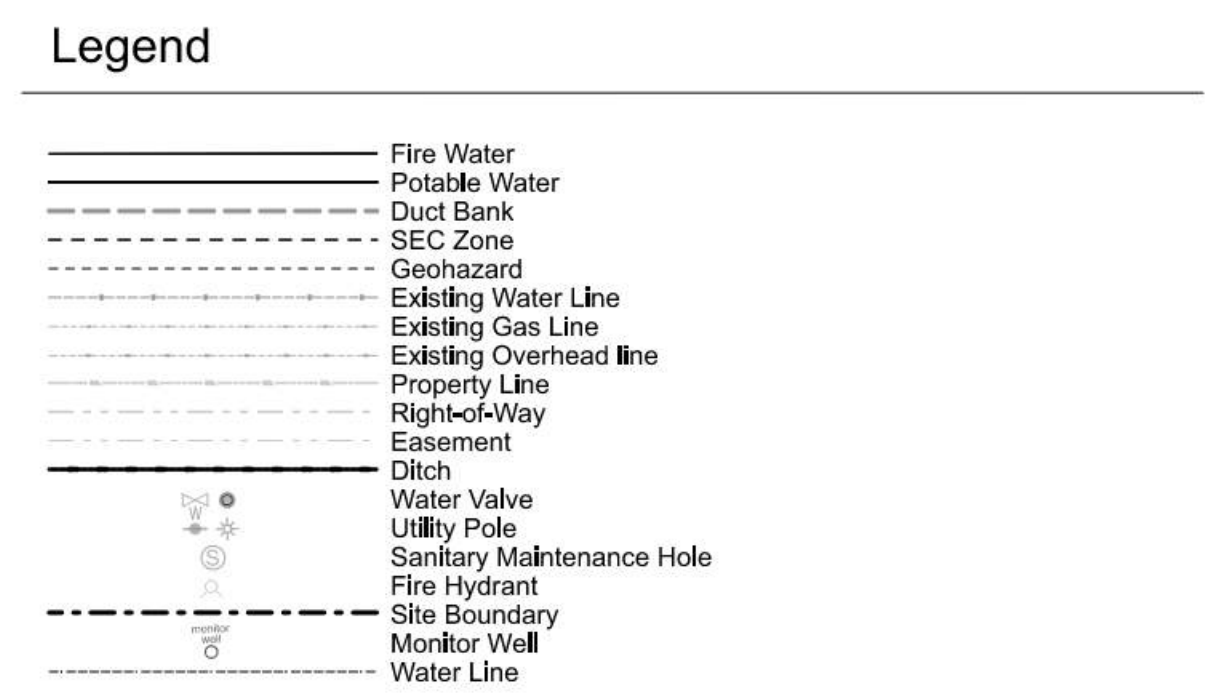

No	Date	Description	Appd
C	09/2022	Second Intermediate Design and BCOE Review - 90% Submittal	MRG
B	01/2022	Intermediate Design - 60% Submittal	MRG
A	07/2021	Initial Design - 30% Submittal	MRG
No			



Designed By	JSL	Program Mgr	MRP
Drawn By	BS	Const Mgr	XXX
Checked By	ERG	Const Supvr	MRX
Project Mgr	MRK	Date	09/02/22



David W. Peters, Engineering Manager, PE No 16683



Bull Run Filtration Facility
Civil
Utility Plan
Filtration Facility
Exhibit A.212.e



SAP Project No
W02229
1/4 Section
3765 / 3766
Sheet No
00-LU-303
3 of 10

Plot Date: 19-SEP-2022 20:04 User: stanpw11-pwsvic Files: W02229_FF_00-LU-304.dgn Model: 00-LU-304 ColorTable: bw_plot.ctb DesignScript: PWB_PenTable.pen PlotScale: 0.0833333:1

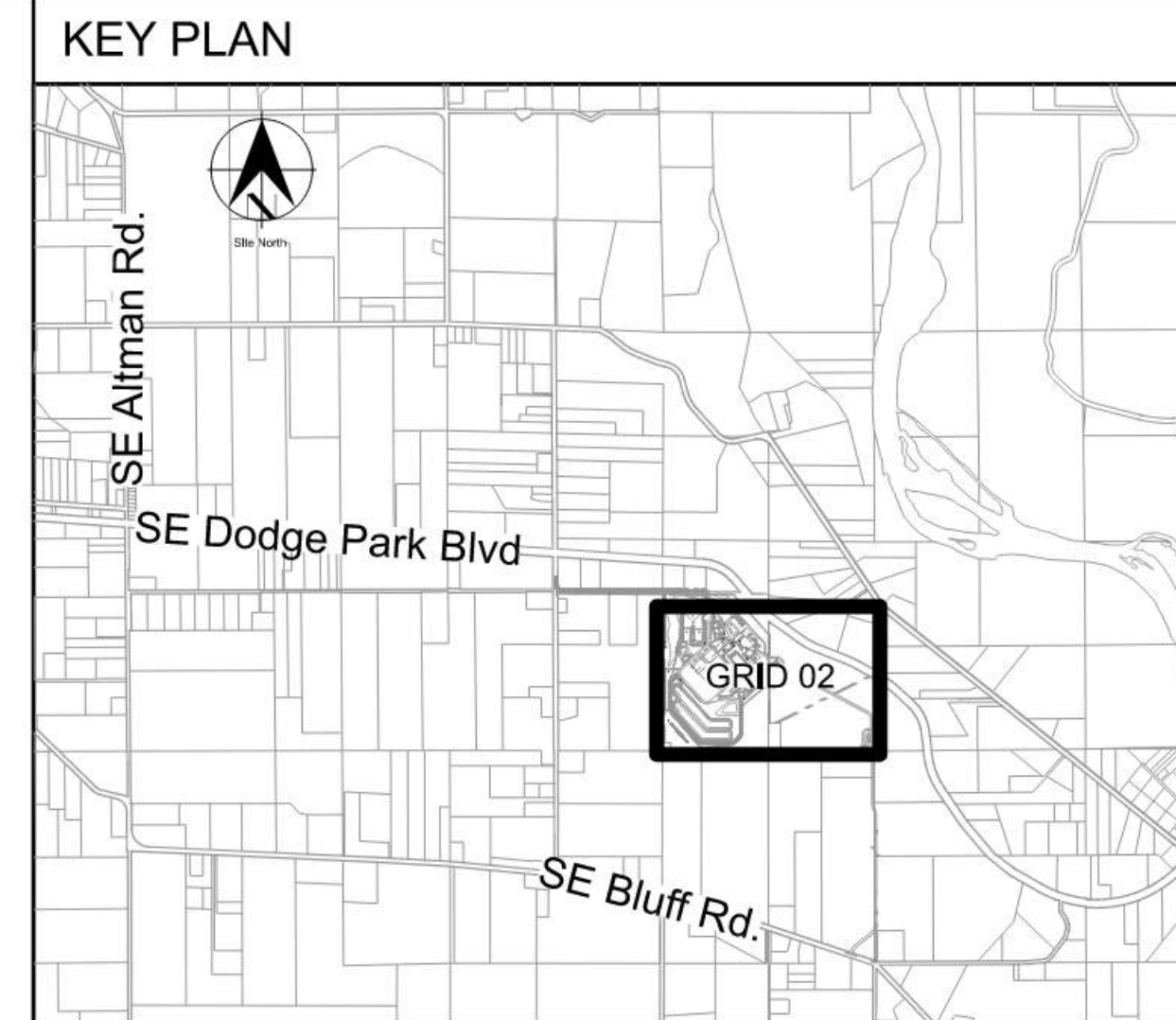
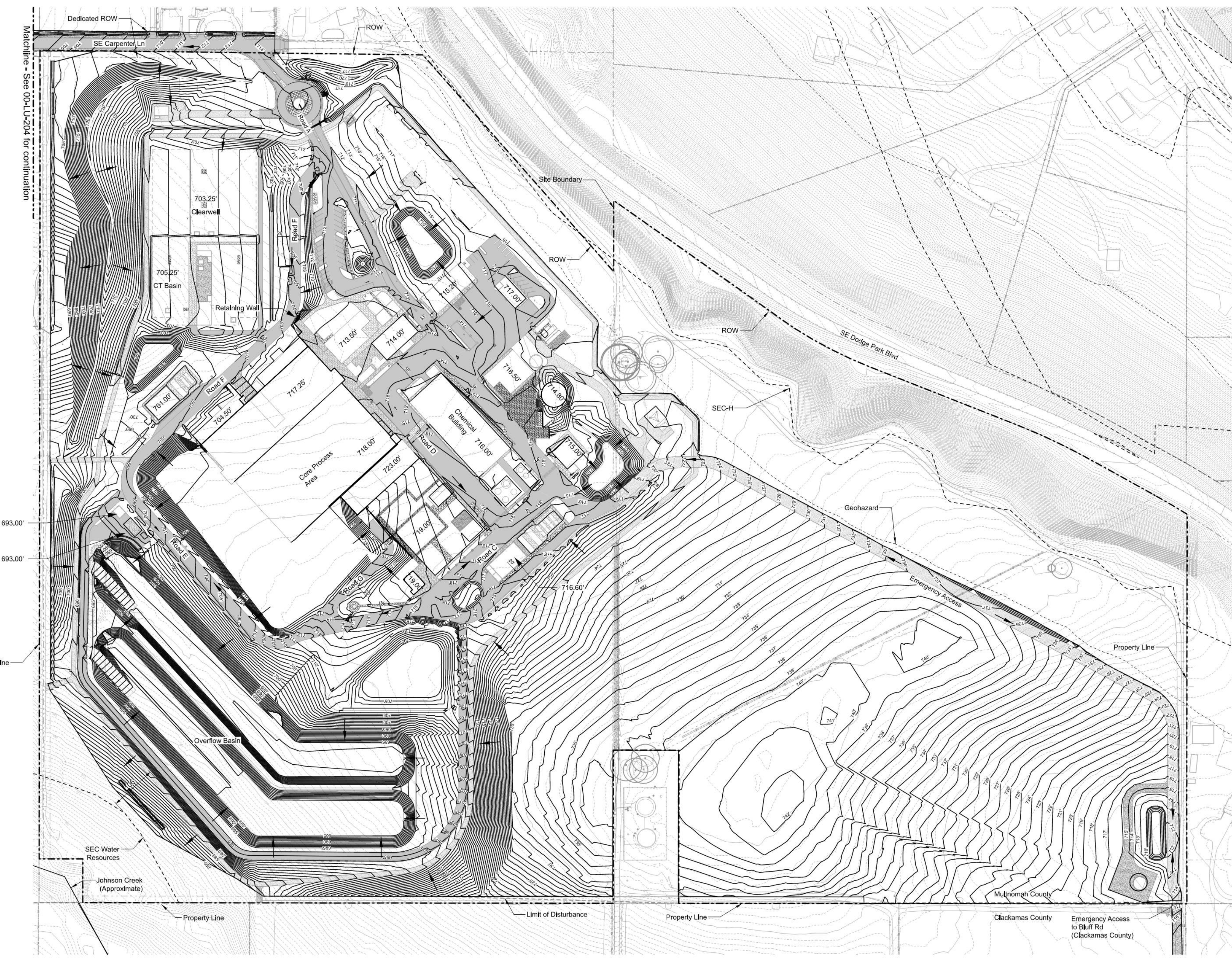

Legend

	Major Contour
	Minor Contour
	Existing Major Contour
	Existing Minor Contour
	SEC Zone
	Geohazard
	Deciduous Tree
	Evergreen Tree
	Existing Water Line
	Existing Fence
	Existing Gas Line
	Existing Overhead Line
	Existing Structure
	Existing Edge of Vegetation
	Property Line
	Right-of-Way
	Easement
	Ditch
	Water Valve
	Utility Pole
	Sanitary Maintenance Hole
	Edge of Gravel
	Fire Hydrant
	Site Boundary

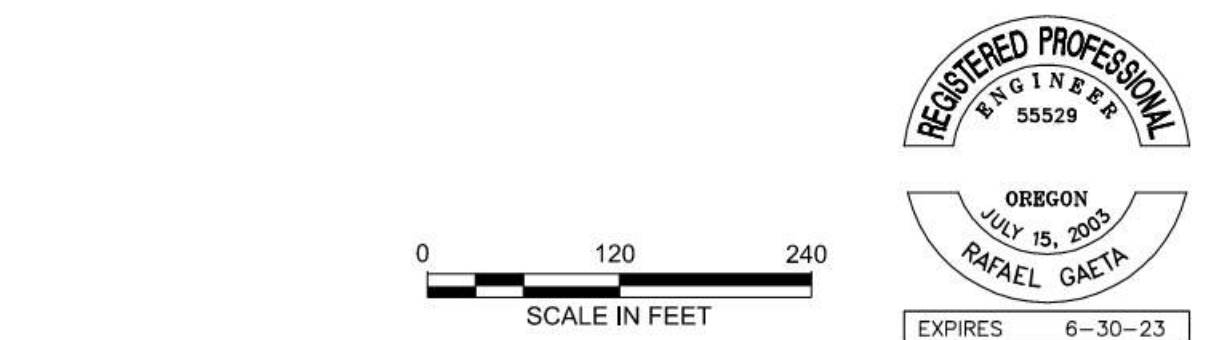

No	Date	Description	Appd
C	09/2022	Second Intermediate Design and BCOE Review - 90% Submittal	MRG
B	01/2022	Intermediate Design - 60% Submittal	MRG
A	07/2021	Initial Design - 30% Submittal	MRG
No			



Designed By	JSL	Program Mgr	DWP
Drawn By	BYS	Const Mgr	TG
Checked By	RC	Const Supvr	RM
Project Mgr	MRG	Date	09/02/22



David W. Peters, Engineering Manager, PE No 16683



Bull Run Filtration Facility

Civil
Grading Plan
Filtration Facility

SAP Project No
W02229

1/4 Section
3765 / 3766

Sheet No
00-LU-304

4 of 10

Exhibit A.212.f

Plot Date: 30-AUG-2022 10:05 User: JASON
 File: W02229-FF-00-LU-305.dgn Model: Layout1 ColorTable: user attached from dialog DesignScript: PWB_PenTable.pen PlotScale: 1:0.08333333

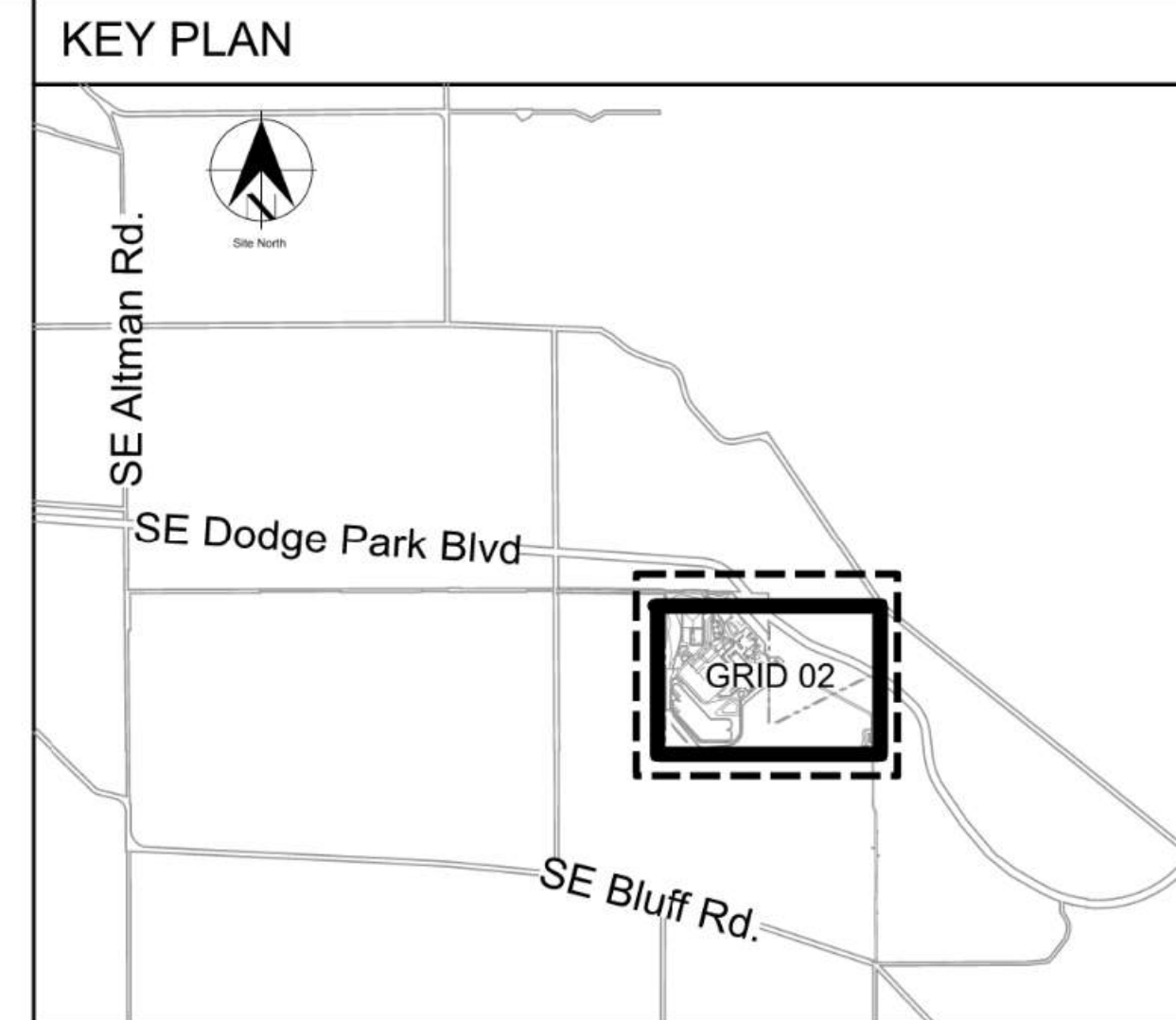
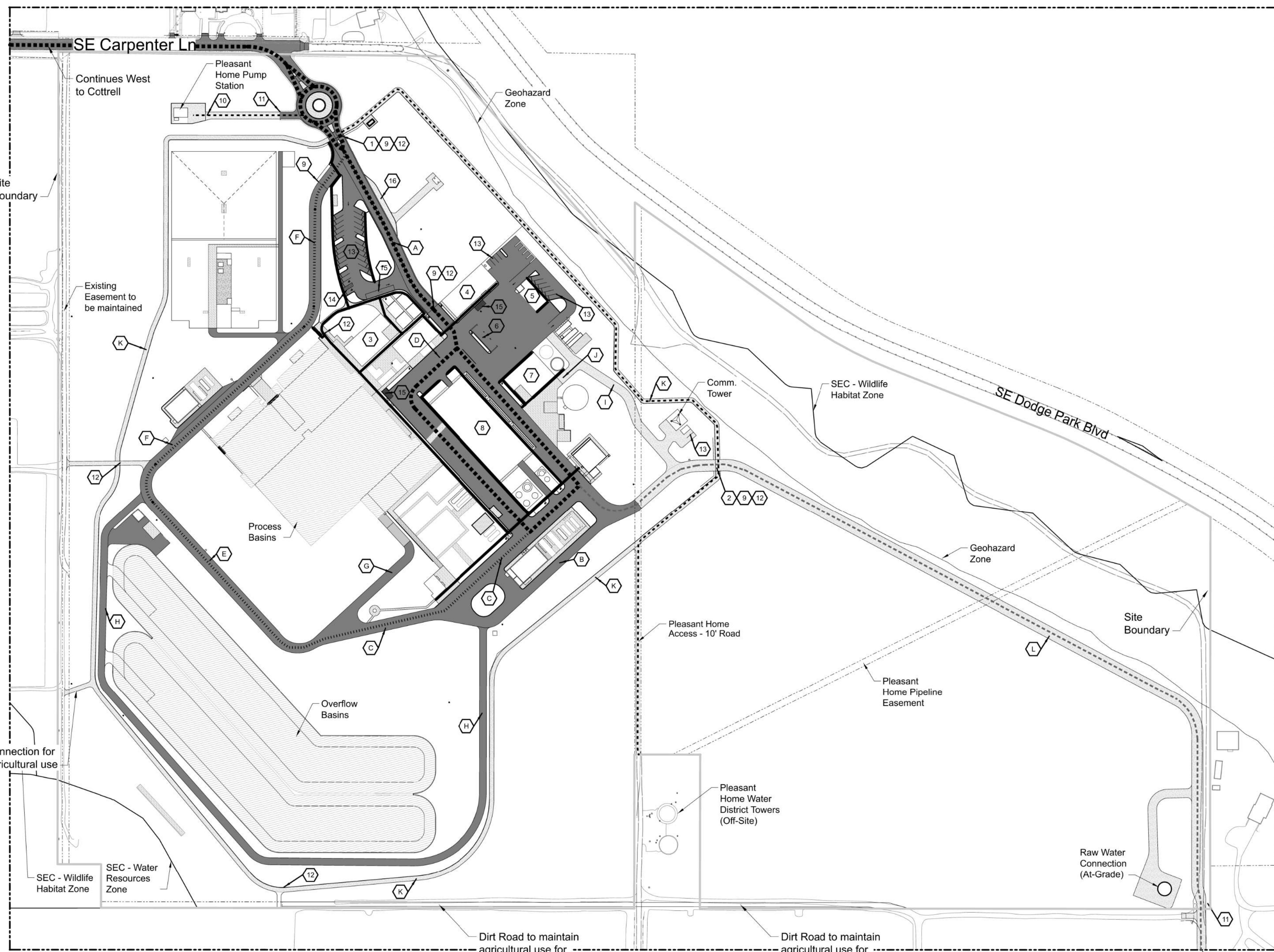

- Sheet Keynotes**
- | | |
|--|------------------------------------|
| 1. Carpenter Lane Entry | 9. Automated Vehicle Gate |
| 2. Emergency Access Entry | 10. Manual Vehicle Gate |
| 3. Administration Building (Mail Delivery) | 11. Manual Bar Gate |
| 4. Maintenance Building | 12. Pedestrian Gate |
| 5. General Storage Building | 13. Parking Area |
| 6. Refuse / Recycling Storage (Pickup) | 14. ADA Parking (2 spots + refuge) |
| 7. Solids Handling Building | 15. Loading Zone |
| 8. Chemical Building | 16. Bus Parking Area |

- Road Keynotes**
- | | | |
|---------------------|---------------------------|------------------------------|
| A. Road A | - Width varies 26' to 63' | - Asphalt Surface |
| B. Road B | - 20' Width | - Asphalt Surface |
| C. Road C | - 26' and 40' Width | - Asphalt Surface |
| D. Road D | - 54' Width | - Asphalt Surface |
| E. Road E | - 26' Width | - Asphalt Surface |
| F. Road F | - 26' Width | - Asphalt Surface |
| G. Road G | - 20' Width | - Asphalt Surface |
| H. Road H | - 16' Width | - Asphalt Surface |
| I. Road I | - 20' Width | - Gravel Surface |
| J. Road J | - 20' Width | - Asphalt and Gravel Surface |
| K. Perimeter Road | - 10' Width | - Gravel Surface |
| L. Emergency Access | - 26' Width | - Gravel Surface |

- General Sheet Notes**
- Unlabeled paved areas are operational / maintenance access routes.

- Legend**
- Main Truck / Access Route - Chemical Delivery, Solids Removal, Process Circulation, General Deliveries
 - Secondary Truck Route - Fuel Delivery, Alternative Chemical and Solids Use
 - Emergency Access Route - Connects to Bluff Rd. to the south
 - Pleasant Home Access Routes - Tank and Pump Station accesses
 - Main Pedestrian Routes
 - Site Boundary
 - Asphalt Paving - Vehicular Focus
 - Concrete Paving - Pedestrian Focus
 - Crushed Rock Road / Access
 - Basins
 - Lot Line
 - ROW Line
 - Easement Line

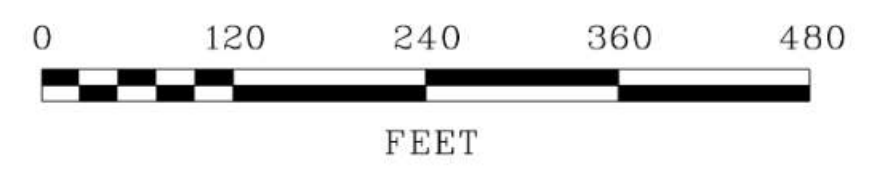

PLAN
SCALE: 1" = 120'-0"

No	Date	Description	Appd
C	09/2022	Second Intermediate Design and BCOE Review - 90% Submittal	MRG
B	01/2022	Intermediate Design - 60% Submittal	MRG
A	07/2021	Initial Design - 30% Submittal	MRG
No			



Designed By	NNA	Program Mgr	MRG
Drawn By	NNA	Const Mgr	MRG
Checked By	NNA	Const Supvr	MRG
Project Mgr	MRG	Date	09/02/22



David W. Peters, Engineering Manager, PE No 16683



Bull Run Filtration Facility
Land Use Plans
Facility Circulation Map

Exhibit A.212.g

SAP Project No	W02229
1/4 Section	-
Sheet No	00-LU-305
	7 of 18

Plot Date: 30-AUG-2022 10:15 User: JASON File: W02229-FF-00-LU-306.dgn Model: Layout1 ColorTable: user attached from dialog DesignScript: PWB_PenTable.pen PlotScale: 1:0.0833333

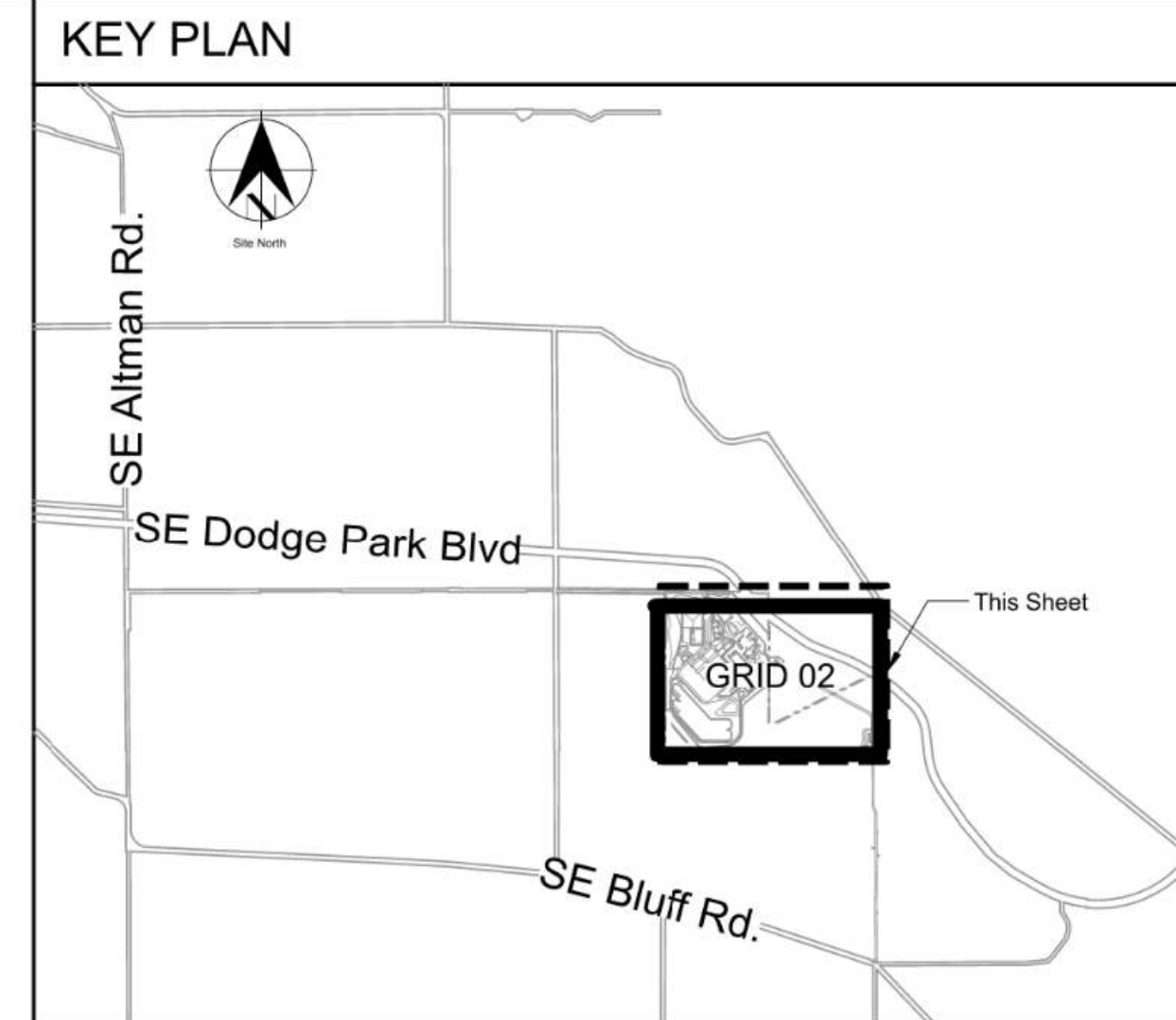
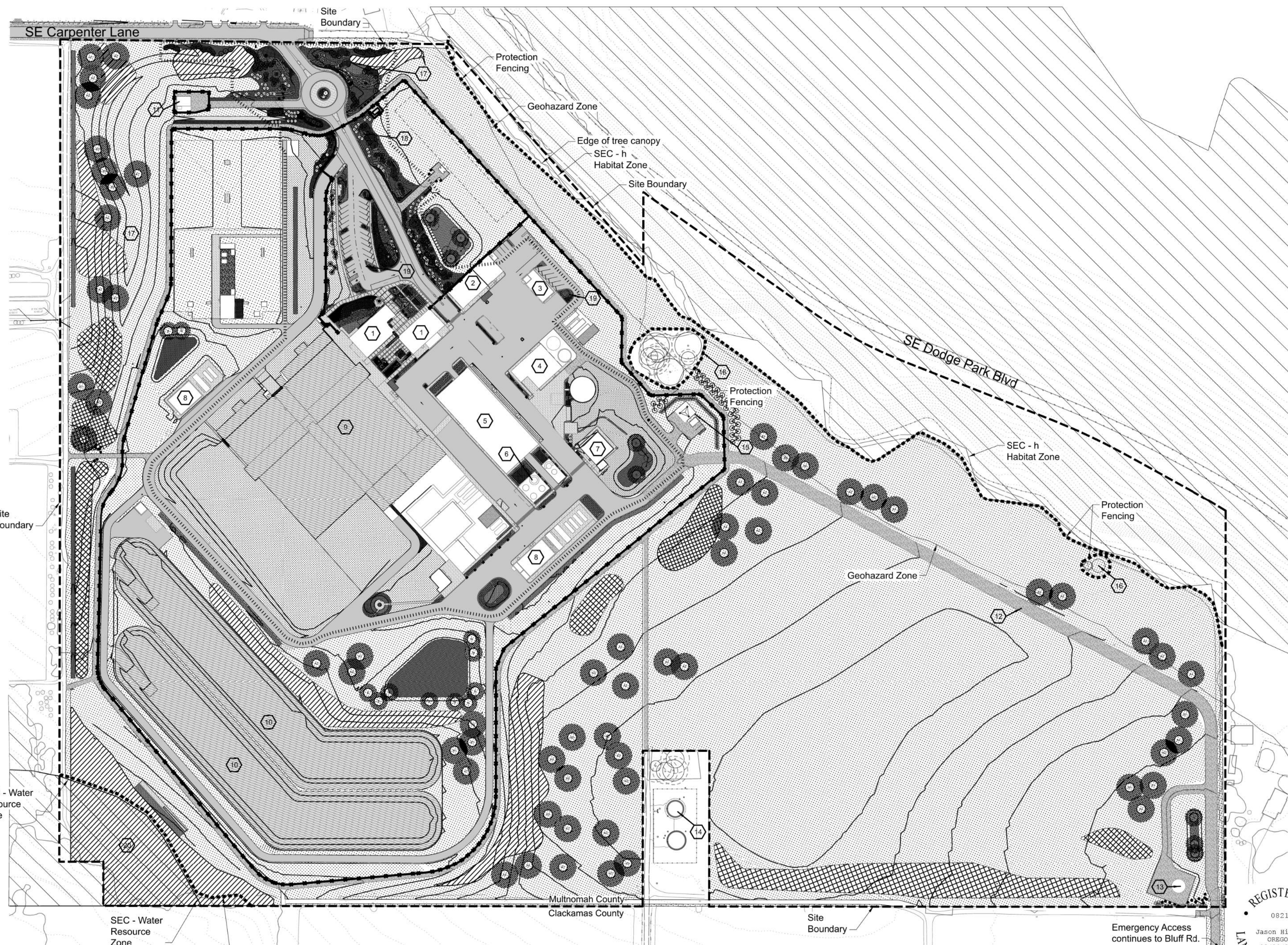

- Sheet Keynotes**
- | | |
|--------------------------------|---|
| 1. Administration Building | 12. Emergency Access Route |
| 2. Maintenance Building | 13. Raw Water Pipeline Cover (At-Grade) |
| 3. General Storage Building | 14. Pleasant Home Water Towers (Off-Site) |
| 4. Mechanical Dewatering Bldg. | 15. Communication Tower Area (See Planting Note 1) |
| 5. Chemical Building | 16. Existing Trees to Remain |
| 6. Chemical Storage Tanks | 17. Planted Berm for Screening |
| 7. Washwater Clarification | 18. Plantings at Facility Entry (See Planting Note 2) |
| 8. Electric Building | 19. Parking Area plantings (See Planting Note 3) |
| 9. Filtration Basins | 20. SEC Water Resource Area (See Planting Note 4) |
| 10. Overflow Basins | |
| 11. Pleasant Home Pumpstation | |

- Planting Notes**
- Communication Tower Area planting is designed to meet screening and parking requirements. See sheet LU-402 for enlargement and more detail on specific requirements.
 - Plantings around facility buildings are of a more ornamental nature and are proposed as containerized plants which will have supplemental irrigation. See sheet LU-400, 401 and 402 for enlargements to see plant sizes and locations in this area. Additional seeded areas shown within facility also may receive supplemental irrigation as a fire risk mitigation measure. See outlined area.
 - Parking Area plantings - See sheets LU-400 and LU-402 for enlargements to see locations of parking islands with plant sizes to meet parking lot planting requirements and listed by Multnomah County.
 - SEC Water Resource Area - This area is currently under agricultural use and has bare soil. Proposed plans have no additional disturbance within this zone. Proposed plantings to be all native species installed with hand tools only.

- General Sheet Notes**
- No development or construction activity proposed within SEC zones on Filtration Site. Native plantings only within these zones.

Legend

Asphalt Paving	Swale Planting
Concrete Paving	Stormwater Planting
Gravel Paving	Screen Mix: Forested Planting
Basins	Screen Mix: Shrubby Planting
Facility Fenceline	Tree / Shrub Planting Clusters
Protection Fencing	Proposed Trees - Deciduous and Evergreen
Areas to receive supplemental irrigation	Landscape Bed - Shrubs, Groundcover, Mulch
Native Grass / Forb Mixes	Existing tree to remain
Significant Environmental Concern (SEC) Zone	

PLAN
SCALE: 1" = 120'-0"

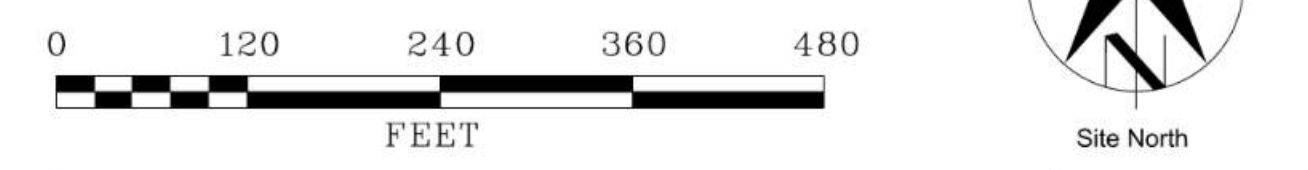

No	Date	Description	Appd
C	09/2022	Second Intermediate Design and BCOE Review - 90% Submittal	MRG
B	01/2022	Intermediate Design - 60% Submittal	MRG
A	07/2021	Initial Design - 30% Submittal	MRG
No			



Designed By	NNA	Program Mgr	MRG
Drawn By	NNA	Const Mgr	MRG
Checked By	NNA	Const Supvr	MRG
Project Mgr		Date	09/02/22



David W. Peters, Engineering Manager, PE No 16683

Bull Run Filtration Facility
Land Use Plans
Landscape Plan

City of Portland Oregon 1851

SAP Project No: W02229
1/4 Section
Sheet No: 00-LU-306
8 of 18

Exhibit A.212.h

Plot Date: 19-SEP-2022 20:04 User: stanpw11-pw-ssc Files: W022229_FF_00-LU-307.dgn Model: 00-LU-307 ColorTable: bw_plot.ctb DesignScript: PWB_PenTable.pen PlotScale: 0.0833333:1

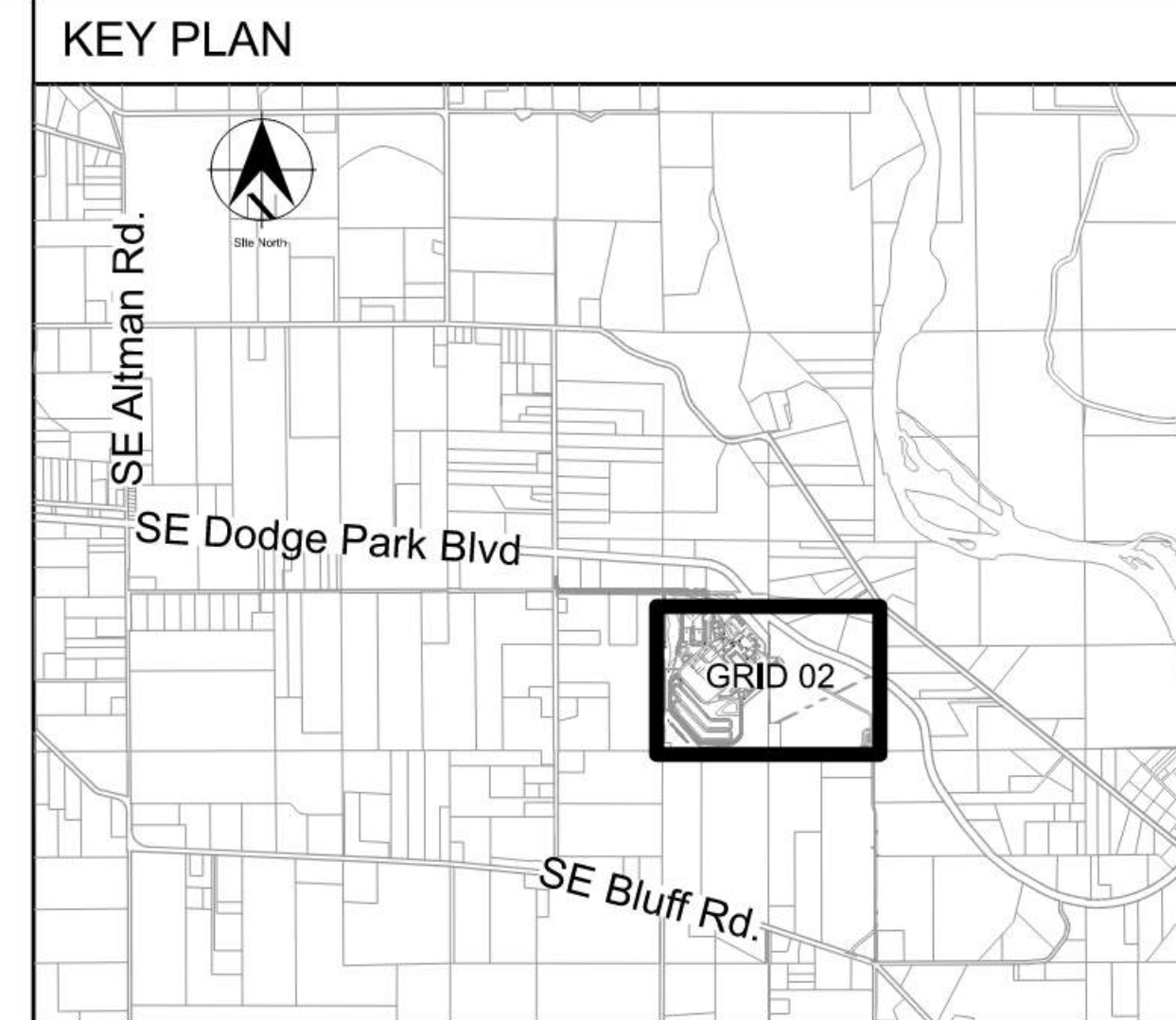
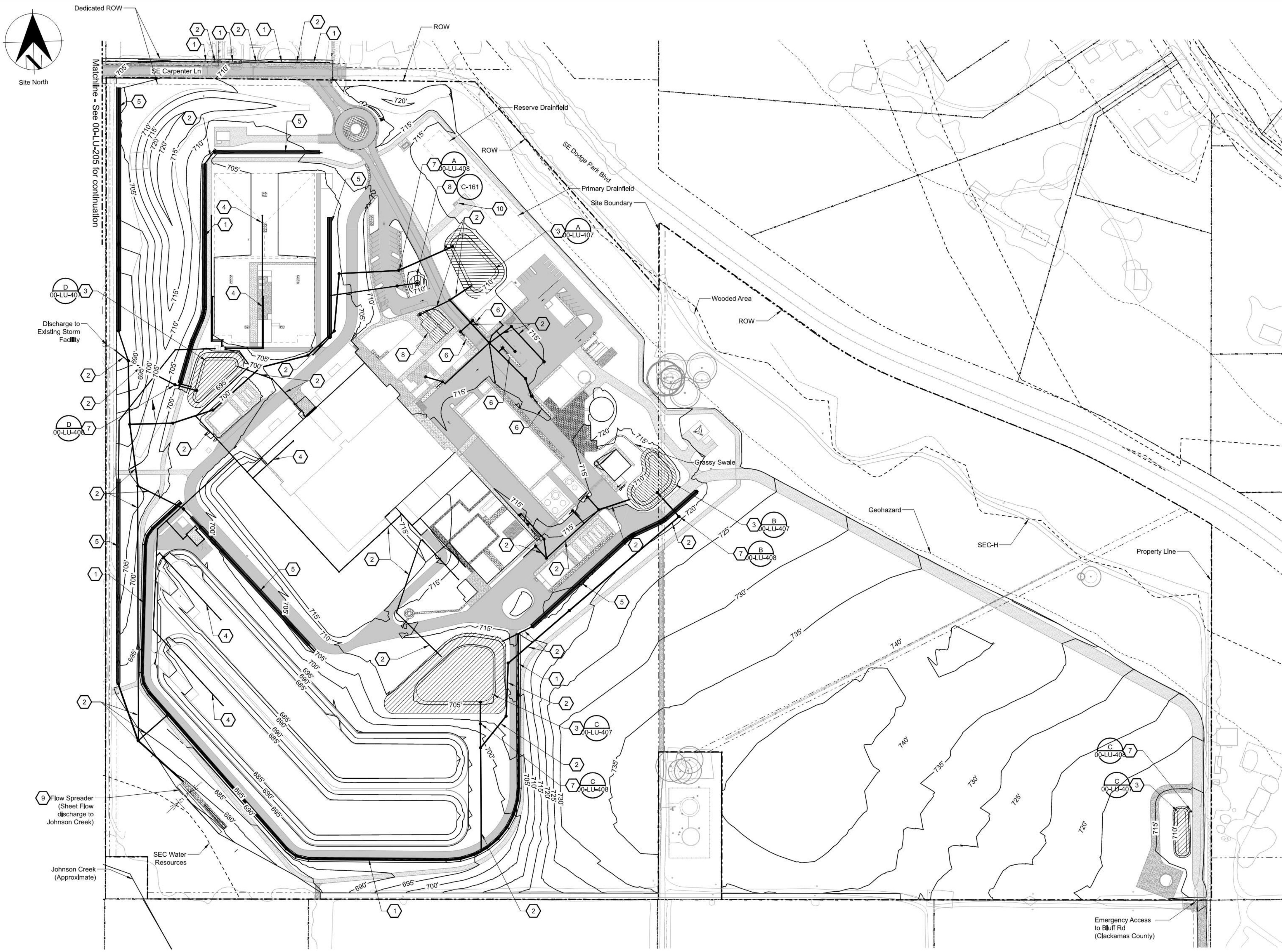

- General Sheet Notes**
1. Refer to Filtration Facility Stormwater Report (Appendix H.1) for stormwater calculations and sizing.
 2. See 00-LU-304 (Grading Plan) for ground disturbance limits.
 3. See 00-LU-306 (Landscape Plan) for propose vegetation.

- Sheet Keynotes**
1. Drainage Ditch per detail C-169/GEN-C-923
 2. Storm Pipes
 3. Detention Pond
 4. Underdrain Storm Pipe
 5. Water Quality Swale per detail C-168/GEN-C-923
 6. Stormwater Planter per detail C-162/GEN-C-920
 7. Flow Control Maintenance Hole
 8. Stormwater Basin per detail C-161/GEN-C-920
 9. Outfall Flow Spreader per detail C-171/GEN-C-923
 10. Septic Tank

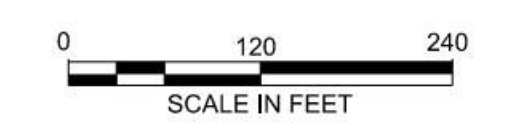
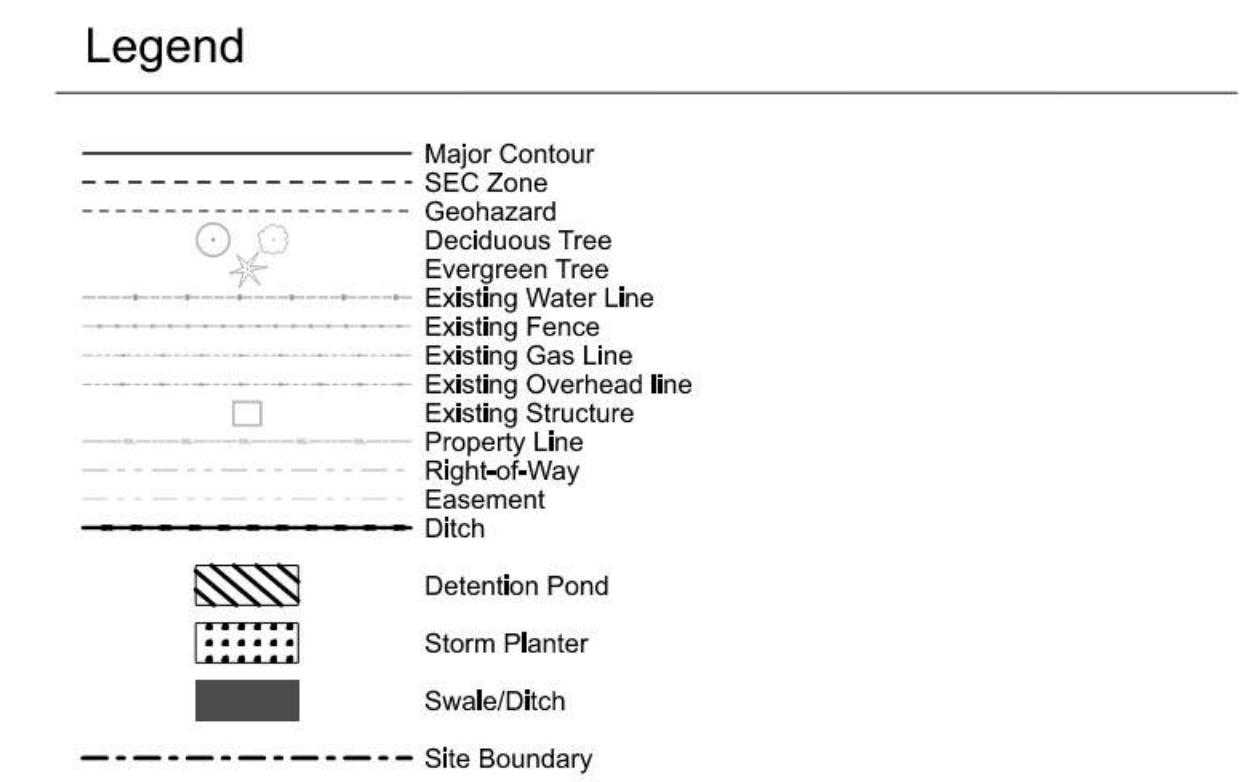

No	Date	Description	Appd
C	09/2022	Second Intermediate Design and BCOE Review - 90% Submittal	MRG
B	01/2022	Intermediate Design - 60% Submittal	MRG
A	07/2021	Initial Design - 30% Submittal	MRG
No			



Designed By	JSL	Program Mgr	MRK
Drawn By	BYS	Const Mgr	XXX
Checked By	ERG	Const Supvr	MRK
Project Mgr	MRK	Date	09/02/22



David W. Peters, Engineering Manager, PE No 16683



Bull Run Filtration Facility
Civil
Stormwater Management Plan
Filtration Facility

SAP Project No
W02229
1/4 Section
3765 / 3766
Sheet No
00-LU-307
3 of 10

Exhibit A.212.i

File: W02229-F0-LU-400.dgn Model: Layout1 ColorTable: user attached from dialog DesignScript: PWB_PenTable.pen PlotScale: 1:0.0833333
 Plot Date: 30-AUG-2022 10:20 User: JASON

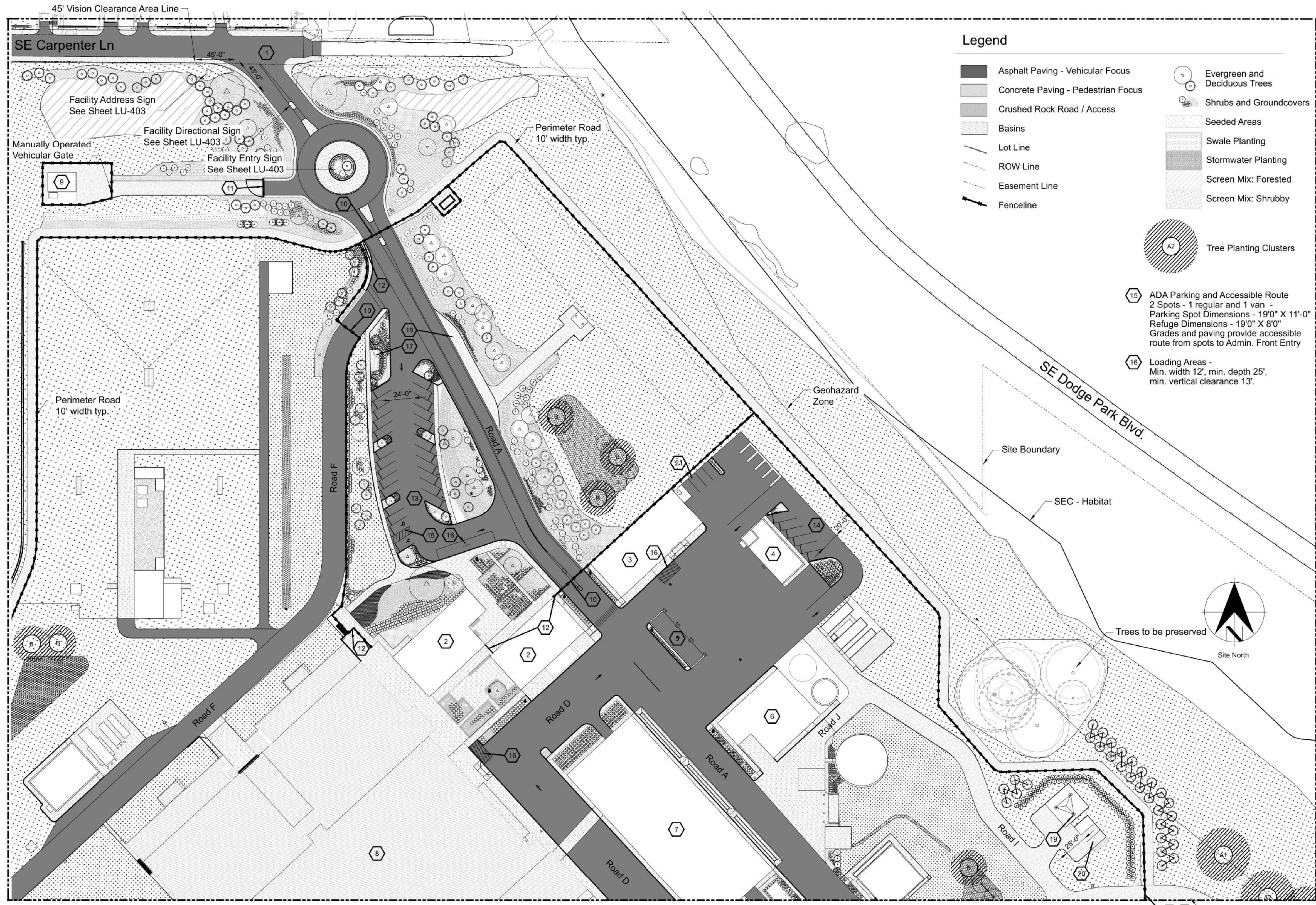

Legend

	Asphalt Paving - Vehicular Focus		Evergreen and Deciduous Trees
	Concrete Paving - Pedestrian Focus		Shrubs and Groundcovers
	Crushed Rock Road / Access		Seeded Areas
	Basins		Swale Planting
	Lot Line		Stormwater Planting
	ROW Line		Screen Mix: Forested
	Easement Line		Screen Mix: Shrubby
	Fenceline		Tree Planting Clusters

15 ADA Parking and Accessible Route
 2 Spots - 1 regular and 1 van -
 Parking Spot Dimensions - 19'0" X 11'-0"
 Refuge Dimensions - 19'0" X 8'0"
 Grades and paving provide accessible route from spots to Admin. Front Entry

16 Loading Areas -
 Min. width 12', min. depth 25',
 min. vertical clearance 13'.

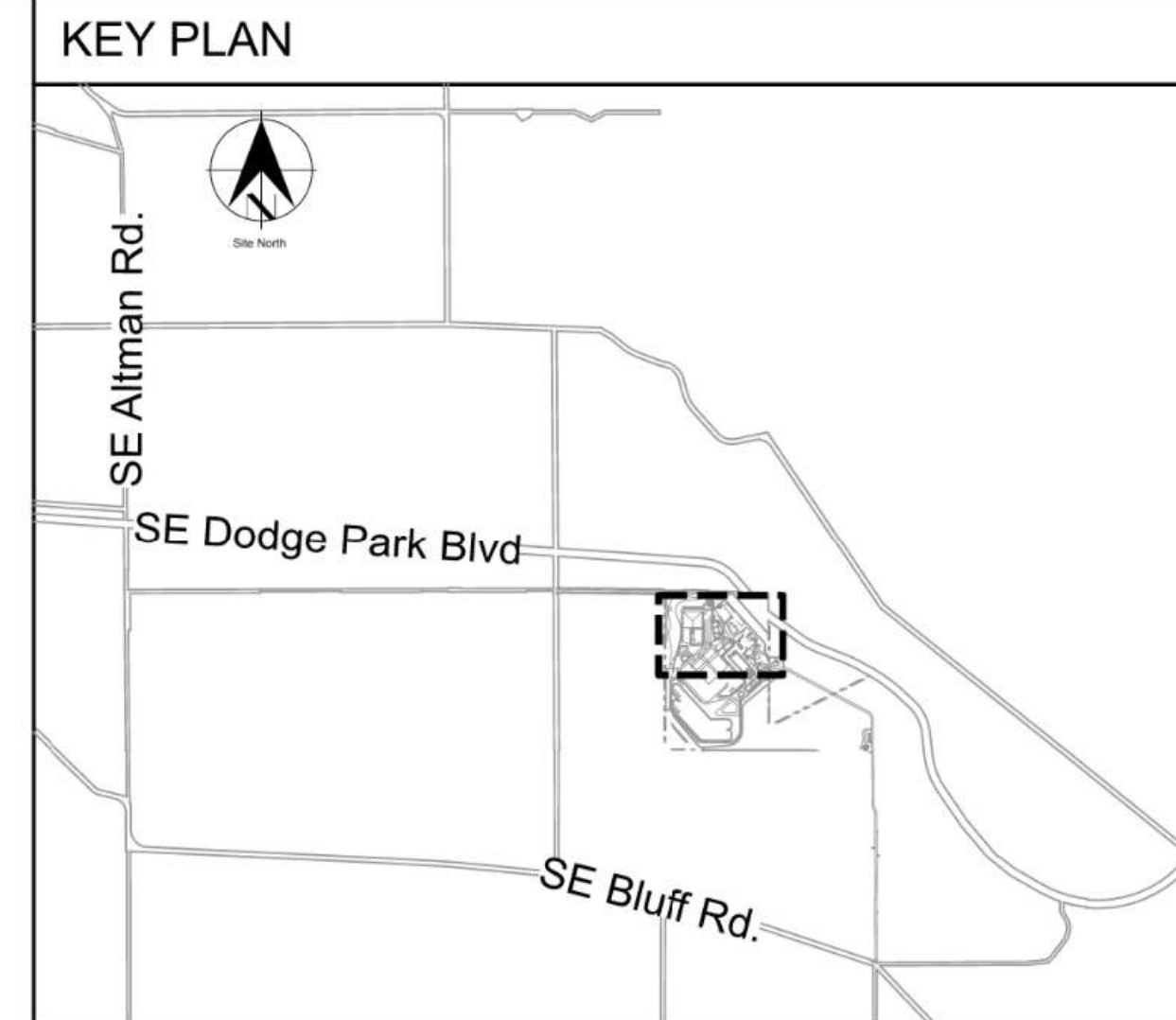

- ### Sheet Keynotes
- | | |
|--|--|
| 1. Carpenter Lane Entry | 11. Manual Bar Gate |
| 2. Administration Building - Mail Drop-Off | 12. Pedestrian Gate |
| 3. Maintenance Building | 13. Parking Area 1 |
| 4. General Storage Building | 14. Parking Area 2 |
| 5. Refuse / Recycling Storage and Pickup | 15. ADA Parking (2 spots + refuge) |
| 6. Solids Handling Building | 16. Loading Zone |
| 7. Chemical Building | 17. Emergency Gathering Area |
| 8. Process Basins | 18. Bus Parking Spot |
| 9. Pleasant Home Pumpstation (Non-PWB) | 19. Comm. Tower and Accessory Building |
| 10. Automated Vehicle Gate | 20. Communication Tower Parking |
| | 21. Parking Area 4 Maintenance |

- ### Requirements
- 13 Parking Area 1 - Administration
 Angled Parking Drive Aisle Width - Requirement is not less than 20'
 Proposed width 23'-6"
 Number of Parking Spots - 23 standard and 2 accessible and 1 Bus (See note 18)
 Area of Landscape - Parking/Loading Area greater than 10 spots requires 25 s.f. per.
 Parking Area 1 requires 625 s.f. - Area proposed exceeds 1,110 s.f. - Min. 5' width.
 Parking Spot Dimensions - 19'-0" X 10'-0"
 Wheelstops Typical - Bumper rails allowing for stormwater passage
 Parking area 1 is set back from closest public road (Carpenter Lane) by
 over 350'. Planted buffer between Admin parking area and Carpenter
 is a min. 60' width and contains numerous evergreen shrubs and trees
 to create continuous screening.
- 14 Parking Area 2 - Fleet Parking
 Angled Parking Drive Aisle Width - Requirement is not less than 20'
 Proposed width 20'-0"
 Number of Parking Spots - 6 standard and 0 accessible
 Area of Landscape - Parking/Loading Area greater than 10 spots requires 25 s.f. per.
 Parking Area 2 requires 0 s.f. - Area proposed exceeds 275 s.f. - Min. 5' width.
 Parking Spot Dimensions - 20'-0" X 10'-0"
 Wheelstops Typical - Bumper rails allowing for stormwater passage
 Parking area 2 is set back from closest public road (Dodge Park Blvd.) by
 over 290'. Existing forest buffer between Fleet parking area and Dodge
 Park Blvd. is minimum 100' width and populated with a dense stand of
 developed evergreen forest forming a visual buffer.
- 19 Parking Area 3 - Tower Parking Area
 Parking Drive Aisle Width - Requirement is not less than 25'
 Proposed width 25'-0"
 Number of Parking Spots - 2 standard and 0 accessible. Non-public area.
 Area of Landscape - Parking/Loading Area greater than 10 spots requires 25 s.f. per.
 Tower Parking Area requires 0 s.f. - Area proposed exceeds 100 s.f. - Min. 5' width.
 Standard Parking Spot Dimensions - 20'-0" X 10'-0"
 Wheelstops Typ. - Bumper rails allowing for stormwater passage
 Tower parking area set back from closest public road (Dodge Park Blvd.) by
 over 330'. Planted buffer between Tower parking area contains 2 rows of large
 evergreen shrubs as well as 2 rows of evergreen trees to exceed the parking
 strip requirement listed in Multnomah County Code.
- 21 Parking Area 4 - Maintenance Parking
 Parking Drive Aisle Width - Requirement is not less than 25'
 Proposed width min. 40'-0"
 Number of Parking Spots - 4 standard and 0 accessible. Non-public area.
 Area of Landscape - Parking/Loading Area greater than 10 spots requires 25 s.f. per.
 Maint. Parking Area requires 0 s.f. - Area proposed exceeds 105 s.f. - Min. 5' width.
 Standard Parking Spot Dimensions - 20'-0" X 10'-0"
 Wheelstops Typ. - Bumper rails allowing for stormwater passage
 Parking area 4 is set back from closest public road ROW (Dodge Park Blvd.) by
 over 195'. Existing forest buffer between Maintenance parking area and Dodge
 Park Blvd. is minimum 100' width and populated with a dense stand of
 developed evergreen forest forming a visual buffer.

See LU-401 for Continuation

REGISTERED
 0821
 Jason Hirst
 OREGON
 02/20/2014
 LANDSCAPE ARCHITECT
 Expires: 02/27/2023

No	Date	Description	Appd
C	09/2022	Second Intermediate Design and BCOE Review - 90% Submittal	MRG
B	01/2022	Intermediate Design - 60% Submittal	MRG
A	07/2021	Initial Design - 30% Submittal	MRG
No		Revision	



Designed By	NNA	Program Mgr	MRG
Drawn By	NNA	Const Mgr	MRG
Checked By	NNA	Const Supvr	MRG
Project Mgr		Date	09/02/22

Warning
 0 1/2 1
 If this bar does not measure 1" then the drawing is not to scale



David W. Peters, Engineering Manager, PE No 16683
 Date

Bull Run Filtration Facility
Land Use Plans
 Facility Enlargement 1

SAP Project No
W02229
 1/4 Section
 Sheet No
LU-400
10 of **18**

Exhibit A.212.j

Plot Date: 29-AUG-2022 16:36 User: JASON File: W02229-F0-LU-401.dgn Model: Layout1 ColorTable: user attached from dialog DesignScript: PWB_PenTable.pen PlotScale: 1:0.0833333

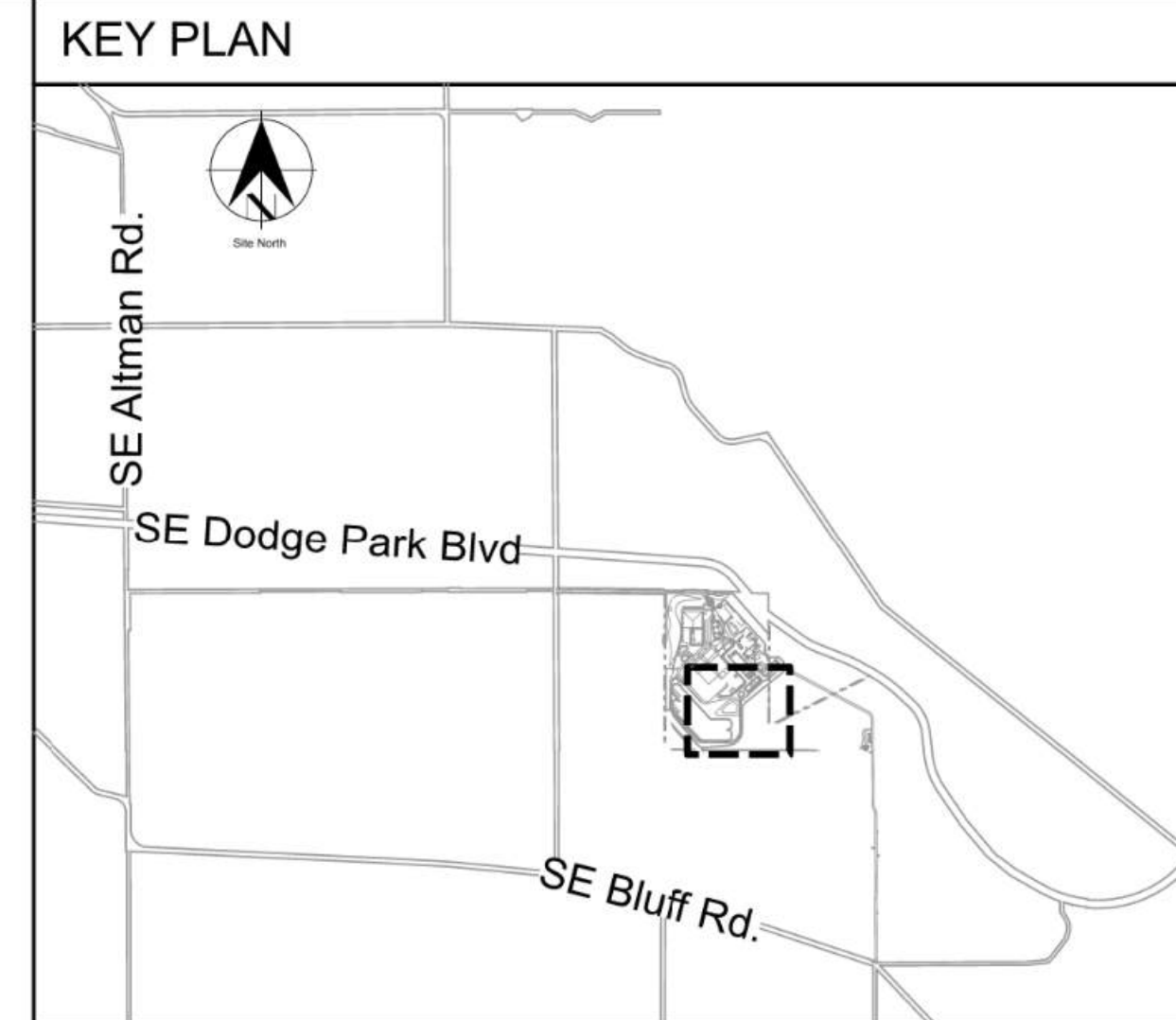
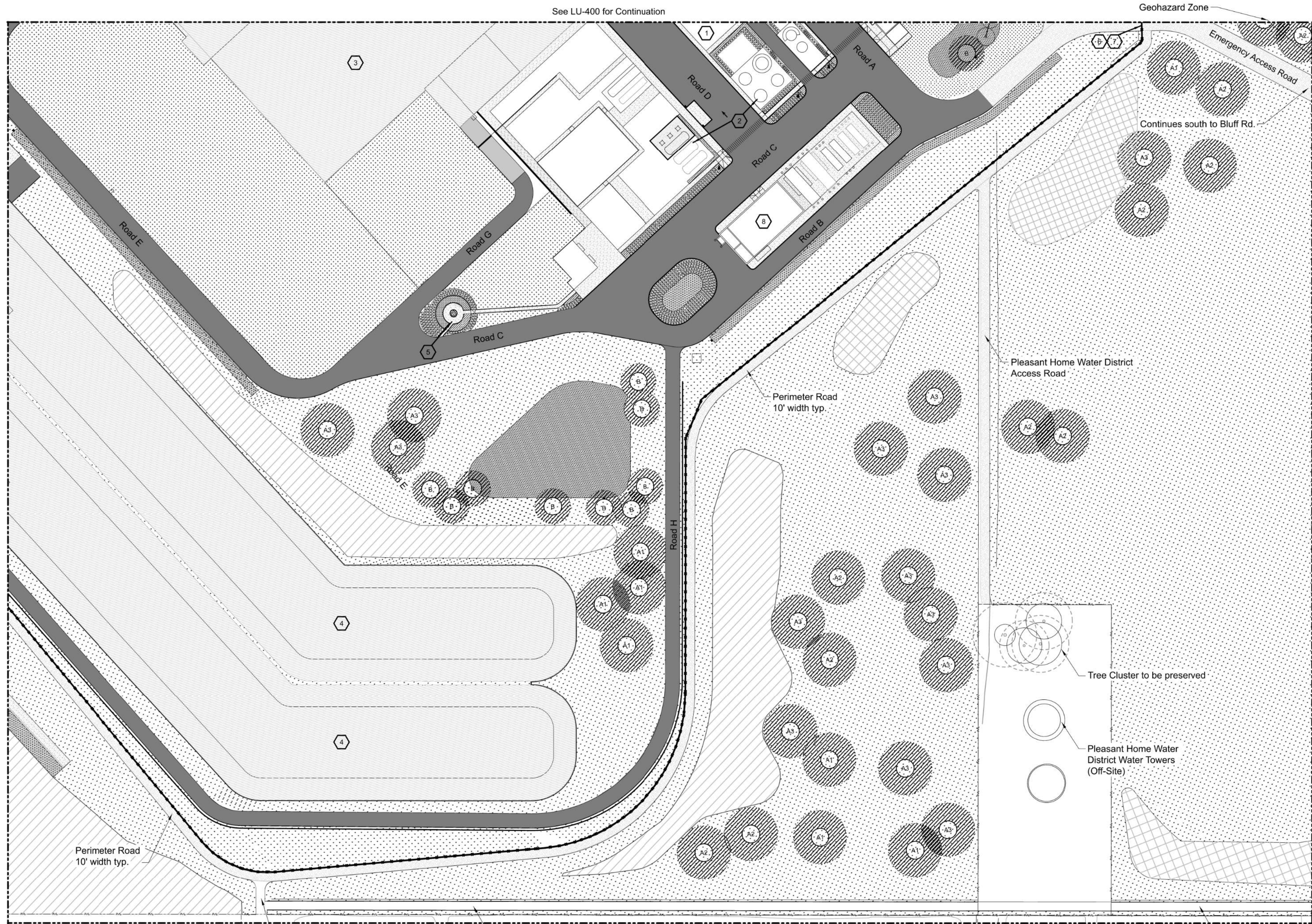

- Sheet Keynotes**
- | | |
|----------------------|-----------------------------|
| 1. Chemical Building | 5. Emergency Gathering Area |
| 2. Storage Tanks | 6. Pedestrian Gate |
| 3. Process Basins | 7. Automatic Vehicular Gate |
| 4. Overflow Basins | 8. Electrical Building |

- Requirements**
- No parking areas in this portion of the facility.
 - Emergency Gathering Area - 550' from Administration Building
 - Accessible Route - 250 s.f. of paved space

- Legend**
- | | |
|------------------------------------|-------------------------------|
| Asphalt Paving - Vehicular Focus | Evergreen and Deciduous Trees |
| Concrete Paving - Pedestrian Focus | Shrubs and Groundcovers |
| Crushed Rock Road / Access | Seeded Areas |
| Basins | Swale Planting |
| Lot Line | Stormwater Planting |
| ROW Line | Screen Mix: Forested |
| Easement Line | Screen Mix: Shrubby |
| Fenceline | |

Tree Planting Clusters

Pleasant Home Water District Water Towers (Off-Site)

Tree Cluster to be preserved

Perimeter Road 10' width typ.

Connection to Access Road/Easement 10' width

Dirt Road for agricultural use

Dirt Road for agricultural use

0 60 120 FEET

REGISTERED LANDSCAPE ARCHITECT Jason Hirst OREGON 02/20/2014 Expires: 02/27/2023

Site North

No	Date	Description	Appd
C	09/2022	Second Intermediate Design and BCOE Review - 90% Submittal	MRG
B	01/2022	Intermediate Design - 60% Submittal	MRG
A	07/2021	Initial Design - 30% Submittal	MRG
No			



Designed By	NINA	Program Mgr	MRG
Drawn By	NINA	Const Mgr	MRG
Checked By	NINA	Const Supvr	MRG
Project Mgr	MRG	Date	09/02/22

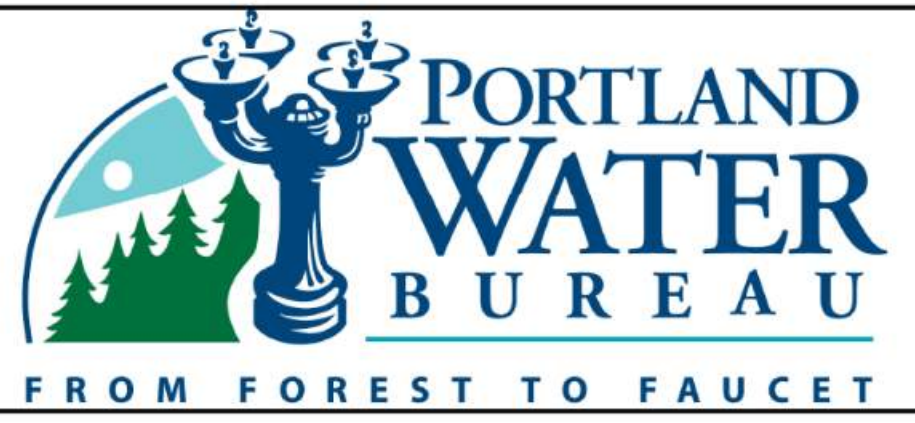

David W. Peters, Engineering Manager, PE No 16683



Bull Run Filtration Facility
Land Use Plans
 Facility Enlargement 2

Exhibit A.212.k

SAP Project No	W02229
1/4 Section	-
Sheet No	LU-401
	11 of 18

Plot Date: 6-SEP-2022 13:53 User: JASON
 File: W02229-FF-00-LU-402.dgn Model: Layout1 ColorTable: user attached from dialog DesignScript: PWB_PenTable.pen PlotScale: 1:0.08333333

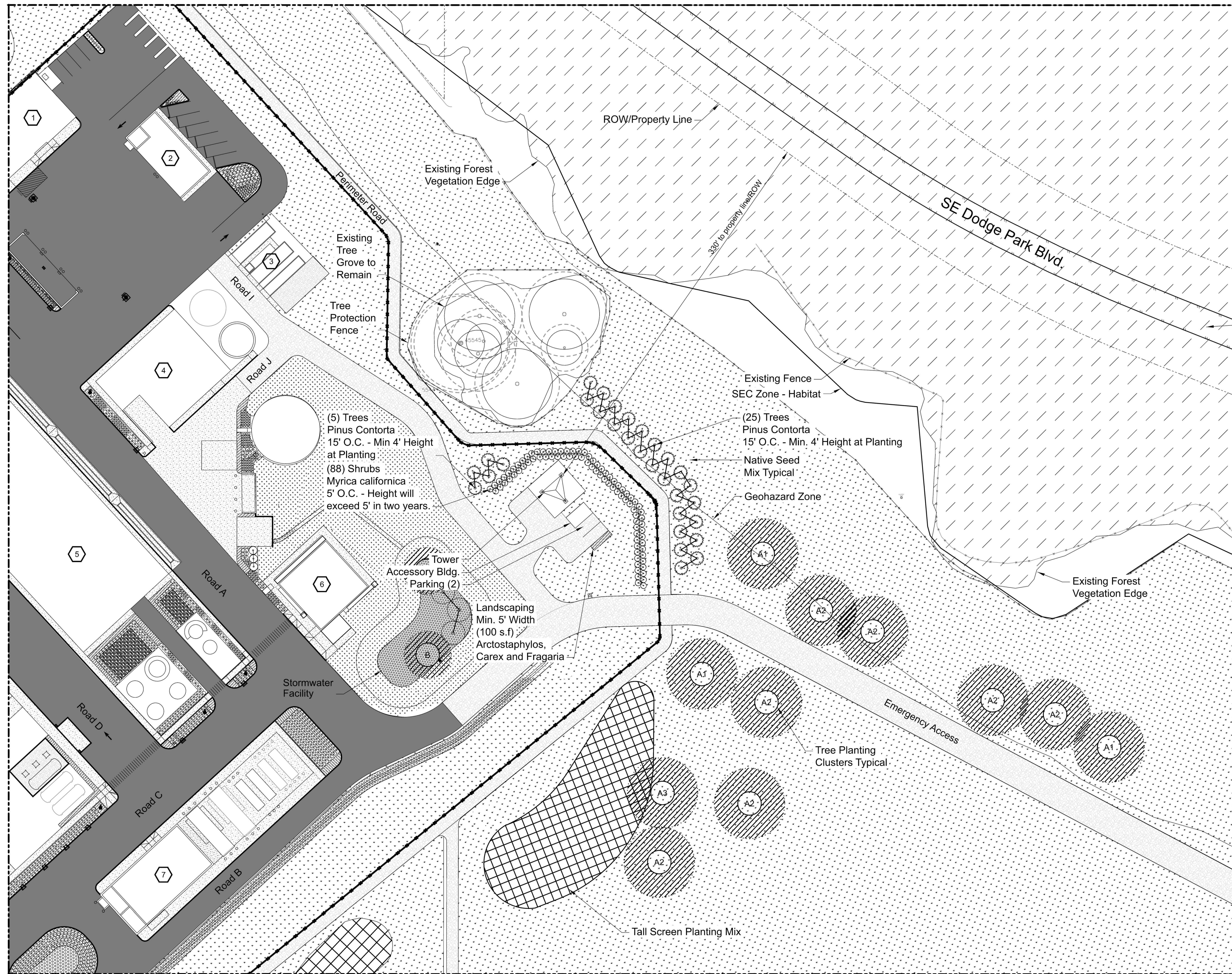

Forest opening over Dodge Park Blvd. Location taken from Multnomah County Mapping

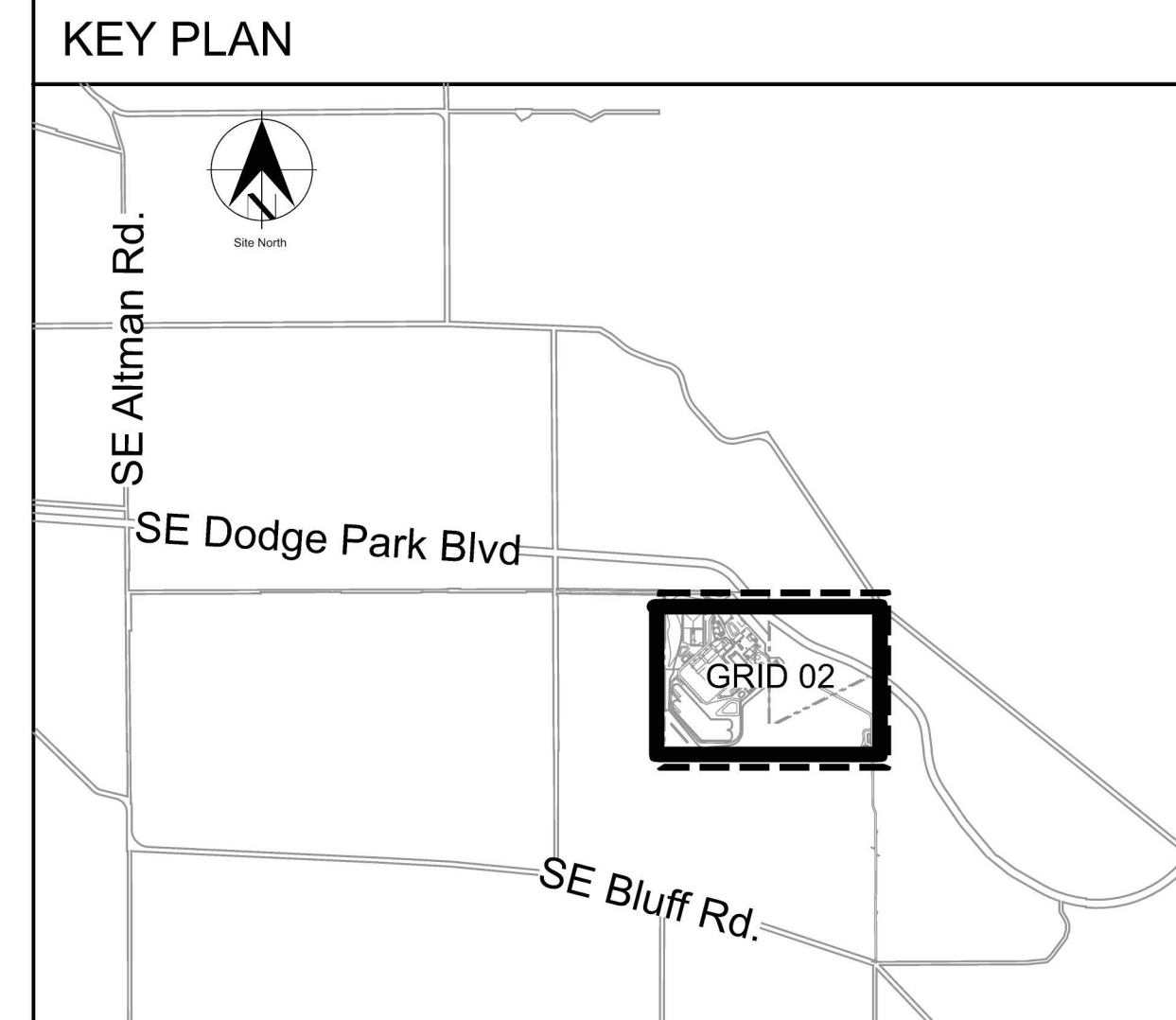

Sheet Keynotes

1. Maintenance Building
2. General Storage Building
3. Pilot Plant
4. Solids Handling Building
5. Chemical Building
6. Washwater Clarification
7. Electrical Building

Tower Screening Requirements and Information

Requirement - Provide Tower Buffer Area of no less than 25 feet wide.
 Response - Buffer area from tower base to adjacent ROW is 330 feet wide.

Requirement - Screening of at least 1 row of evergreen shrubs shall be spaced not more than 5 feet apart. Shall grow to form a continuous hedge 5 feet in height at two years.
 Response - Screening plantings of 2 rows of evergreen shrubs spaced 5' O.C. Materials selected will exceed 5 feet in height at two years.
 (88) Myrica californica - California Wax Myrtle

Requirement - Screening of at least 1 row of evergreen trees, not less than 4' height and spaced not more than 15 feet apart.
 Response - Screening plantings of 2 rows of evergreen trees spaced 15' O.C. Materials planted will exceed 4' height at time of planting.
 (30) Pinus contorta var. contorta - Shore Pine

Distance from Tower to closest property line is 330 Linear Feet.
 Dodge Park Boulevard is approximately 80' downslope from Tower base elevation.

Within the existing tree grove one or more dead trees may be removed under arborists direction. These trees are not within the SEC zone.

Legend

- Asphalt Paving - Vehicular Focus
- Concrete Paving - Pedestrian Focus
- Crushed Rock Road / Access
- Lot Line
- ROW Line
- Easement Line
- Existing Douglas Fir Forest - Vegetation Leads Down Hillside with heights in excess of 100'

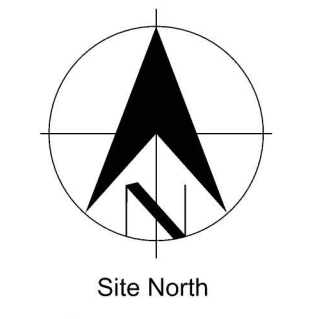
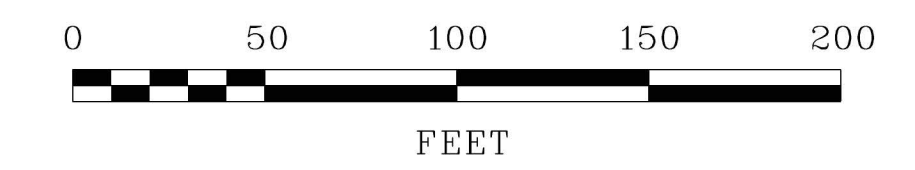

No	Date	Description	Appd
D	12/2022	Response to Completeness Review	MRG
C	09/2022	Second Intermediate Design and BCOE Review - 90% Submittal	MRG
B	01/2022	Intermediate Design - 60% Submittal	MRG
A	07/2021	Initial Design - 30% Submittal	MRG



Designed By	NINA	Program Mgr	MRG
Drawn By	NINA	Const Mgr	MRG
Checked By	NINA	Const Supvr	MRG
Project Mgr	MRG	Date	09/02/22

Warning
 0 1/2 1
 If this bar does not measure 1" then the drawing is not to scale



David W. Peters, Engineering Manager, PE No 16683
 Date



Bull Run Filtration Facility
Land Use Plans
 Tower Area Enlargement
 Exhibit A.212.1

SAP Project No	W02229
1/4 Section	-
Revised Sheet No	00-LU-402
	12 of 18

File: W02229-F00-LU-404.dgn Model: Layout1 ColorTable: user attached from dialog DesignScript: PWB_PenTable.pen PlotScale: 1:0.08333333
 Plot Date: 30-AUG-2022 10:52 User: JASON

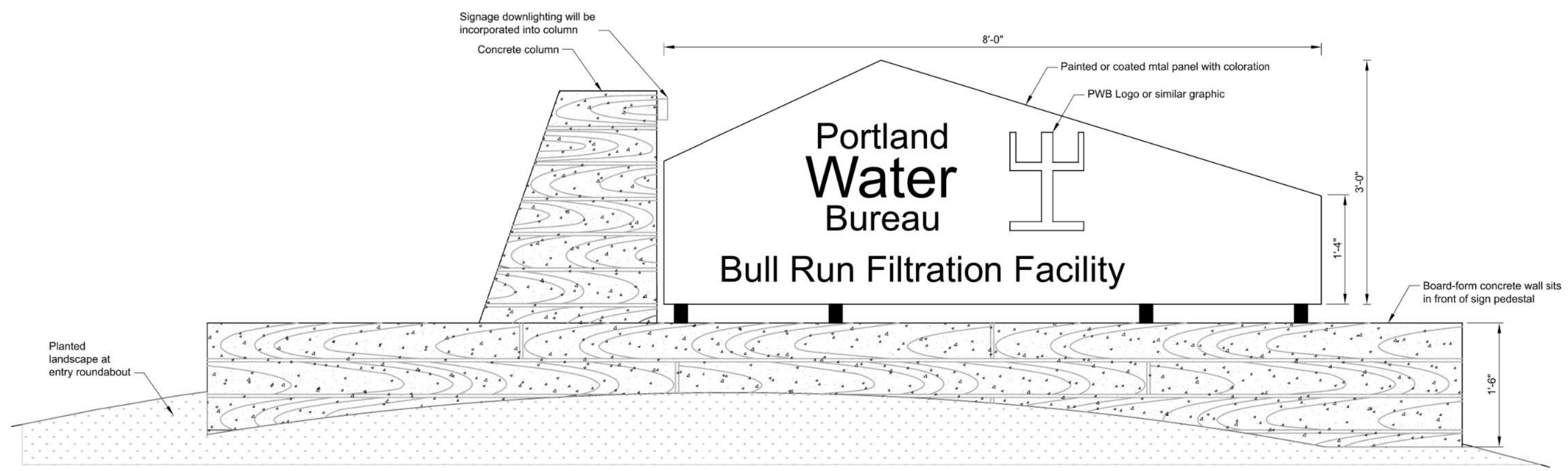

1 Elevation - Monument Entry Sign
NTS

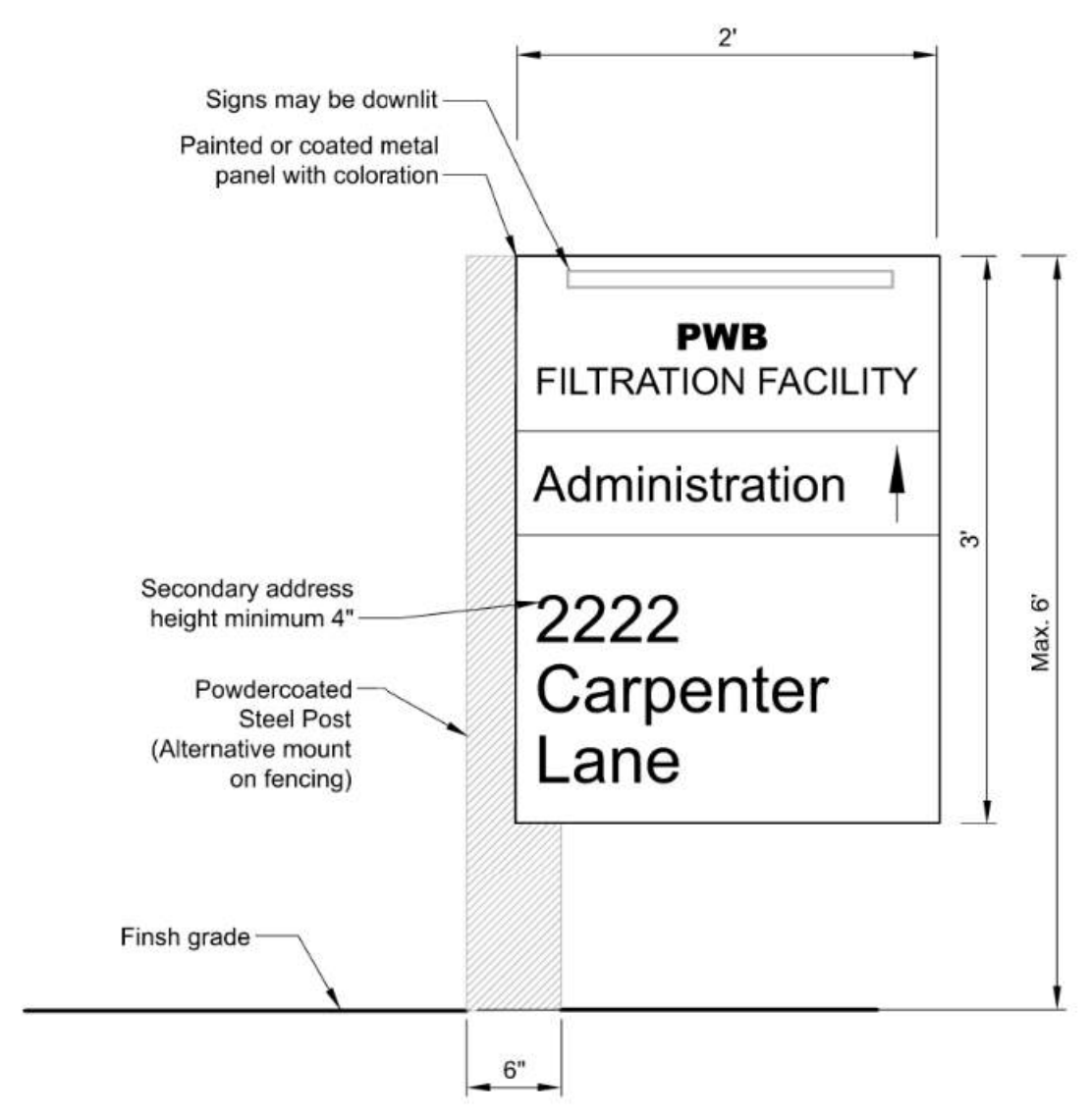

2 Elevation - Directional Sign
NTS

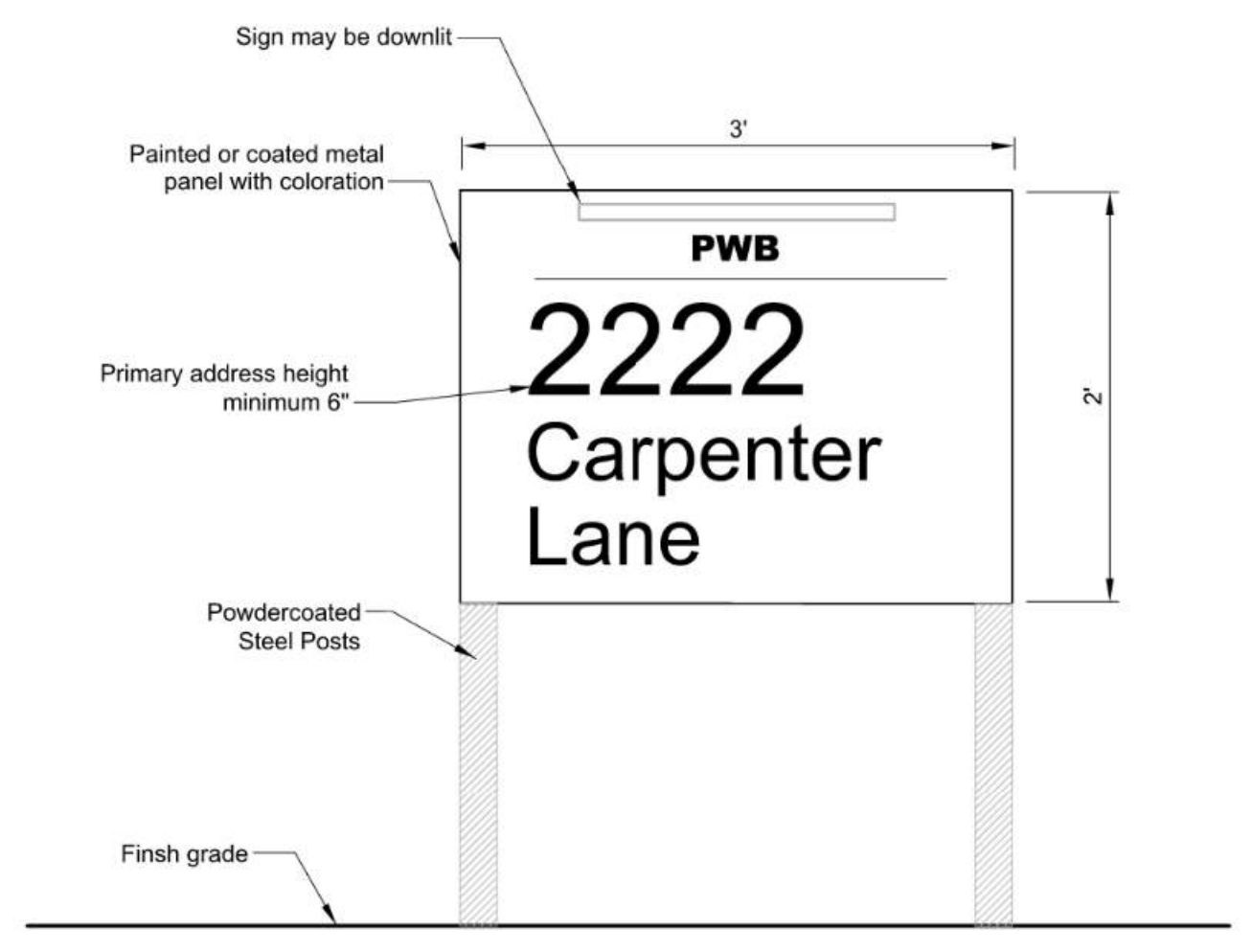

3 Elevation - Address Sign
NTS

No	Date	Description	Appd
C	09/2022	Second Intermediate Design and BCOE Review - 90% Submittal	MRG
B	01/2022	Intermediate Design - 60% Submittal	MRG
A	07/2021	Initial Design - 30% Submittal	MRG
Revision			
Survey			



Designed By	Program Mgr
Drawn By	Const Mgr
Checked By	Const Supvr
Project Mgr	Date
	09/02/22

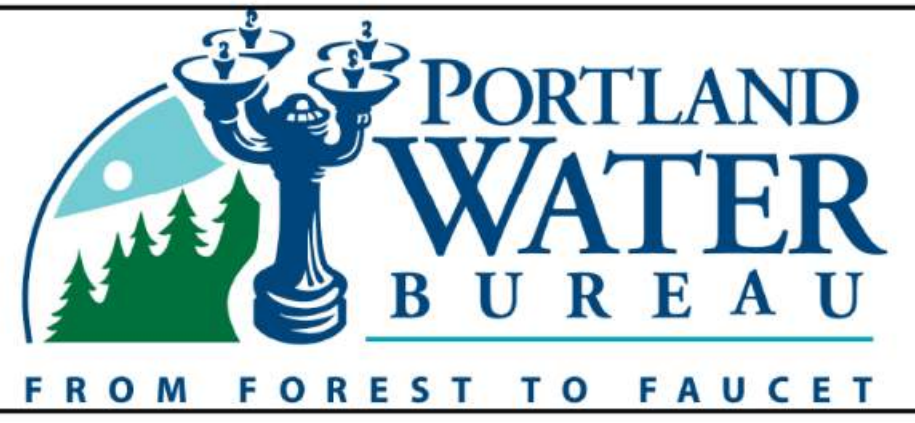

David W. Peters, Engineering Manager, PE No 16683 Date



Bull Run Filtration Facility
Land Use Plans
Details
Signs

Exhibit A.212.m



SAP Project No	W02229
1/4 Section	-
Sheet No	00-LU-403
	13 of 18

Plot Date: 30-AUG-2022 11:27 User: JASON
 File: W02229-FF-00-LU-404.dgn Model: Layout1 ColorTable: user attached from dialog DesignScript: PWB_PenTable.pen PlotScale: 1:0.08333333

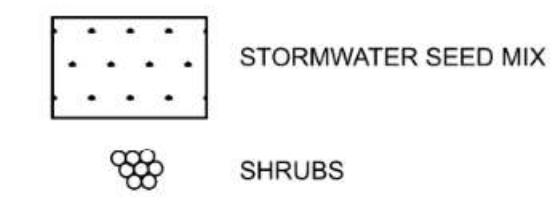
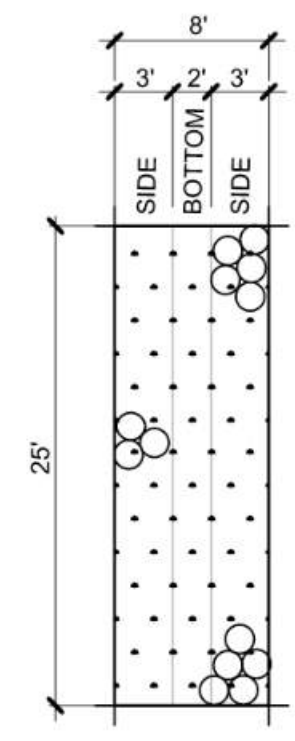
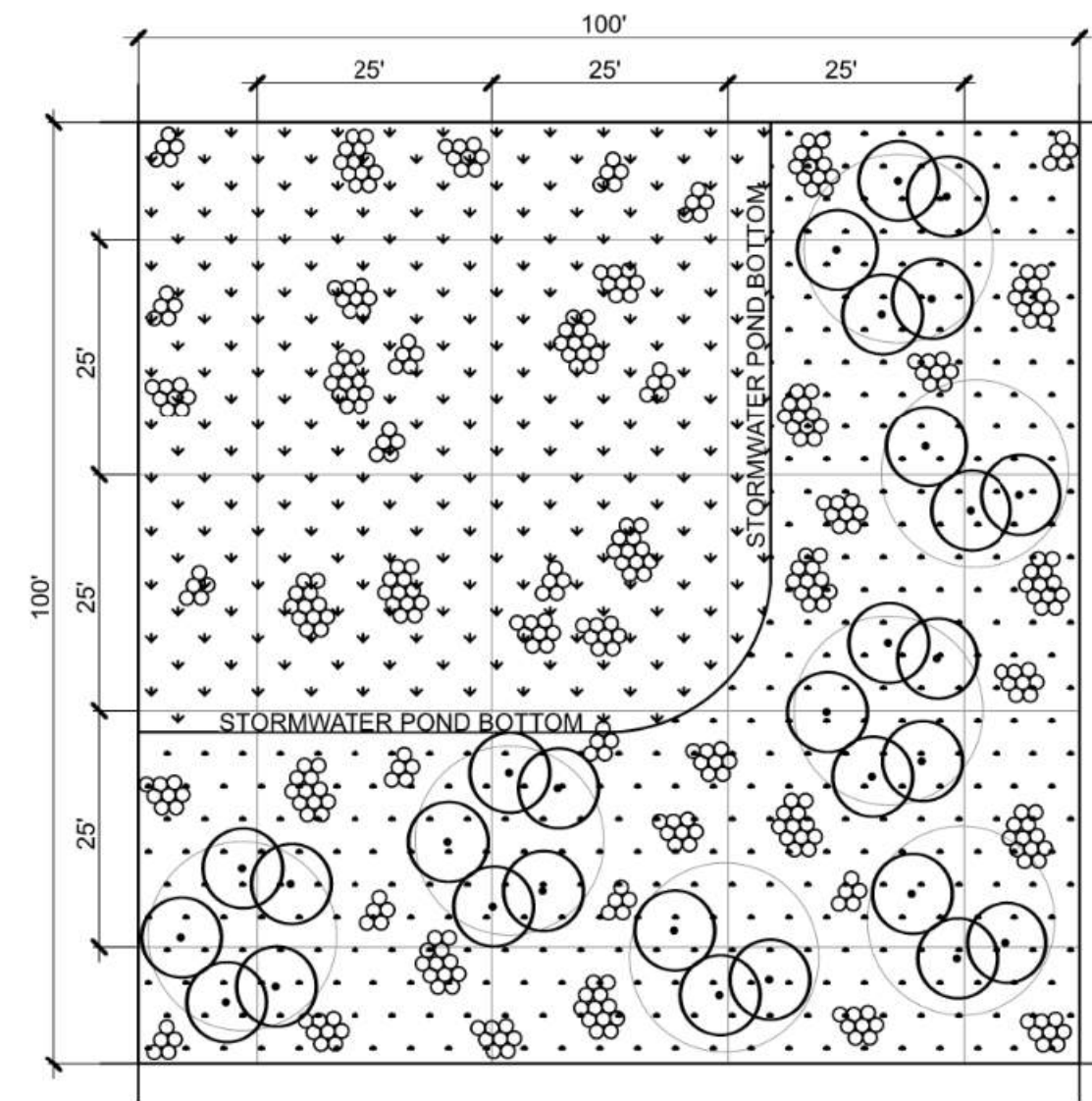

Conveyance Swale - Shrubs	
<i>Mahonia repens</i>	Low Oregon Grape
<i>Rosa pisocarpa</i>	Swamp Rose
<i>Spiraea betulifolia</i>	Birchleaf spirea
<i>Spiraea douglasii</i>	Douglas Spirea

○ Conveyance Swale Planting
NTS



Stormwater Pond Side - Trees	
<i>Alnus rhombifolia</i>	White Alder
<i>Rhamnus purshiana</i>	Cascara
<i>Thuja plicata</i>	Western Red Cedar
Stormwater Pond Side - Shrubs	
<i>Lonicera involucrata</i>	Twinberry
<i>Mahonia aquifolium</i>	Oregon Grape
<i>Physocarpus capitatus</i>	Ninebark
<i>Rosa pisocarpa</i>	Swamp Rose
<i>Ribes sanguineum</i>	Red Floweing Currant
<i>Sambucus racemosa</i>	Red Elderberry
<i>Symphoricarpos albus</i>	Snowberry
Stormwater Pond Bottom - Shrubs	
<i>Cornus sericea</i>	Redtwig Dogwood
<i>Salix sitchensis</i>	Sitka Willow
<i>Salix hookeriana</i>	Hooker's Willow
<i>Spiraea douglasii</i>	Douglas Spirea

○ Stormwater Pond Planting
NTS

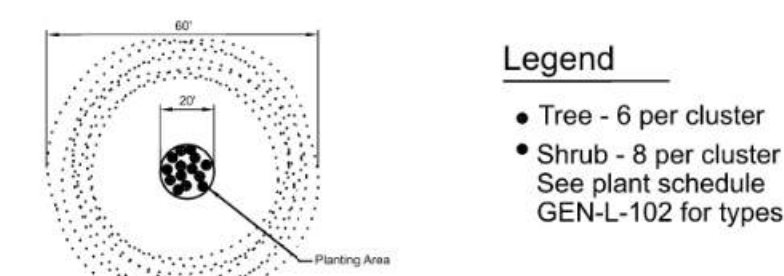

PLAN - PLANTING DIAGRAM FOR B1

B1	Plant Name	Common Name	Quantity
	<i>Mahonia aquifolium</i>	Oregon Grape	1 Gal. size bareroot
	<i>Rhamnus purshiana</i>	Cascara	1/2" Bareroot
	<i>Salix scouleriana</i>	Scouler's Willow	1/2" Bareroot
	<i>Sambucus cerulea</i>	Blue elderberry	1 gal size bareroot
	<i>Symphoricarpos albus</i>	Snowberry	1 Gal. Size Bareroot
	<i>Symphoricarpos mollis</i>	Snowberry	1 Gal. Size Bareroot

○ Stormwater Planting Cluster
NTS

STORMWATER SEED MIXES

These seed mixes are only to be applied to stormwater areas that are depicted with the hatch patterns shown in the sheet legends.

Stormwater - Seed Mix			
Legend	Botanical Name	Common Name	Lbs/Acre
Grasses			
	<i>Danthonia californica</i>	California Oatgrass	5
	<i>Deschampsia cespitosa</i>	Tufted Hairgrass	3
	<i>Deschampsia elongata</i>	Slender Hairgrass	3
	<i>Hordeum brachyantherum</i>	Meadow Barley	1
Flowering Plants			
	<i>Achillea millefolium</i>	Yarrow	0.5
	<i>Aesclepias speciosa</i>	Milkweed	0.5
	<i>Carex densa</i>	Dense Sedge	1
	<i>Carex unilateralis</i>	Lateral Sedge	1
	<i>Juncus patens</i>	Slender Rush	1
	<i>Juncus tenuis</i>	Spreading Rush	1
	<i>Lupinus latifolius</i>	Broadleaf Lupine	0.1
	<i>Potentilla gracilis</i>	Graceful Cinqufoil	0.5

Stormwater Pond Bottom - Seed Mix			
Legend	Botanical Name	Common Name	Lbs/Acre
	<i>Carex densa</i>	Dense Sedge	0.25
	<i>Carex pachystachya</i>	Chamisso Sedge	0.5
	<i>Carex scoparia</i>	Broom Sedge	0.5
	<i>Carex unilateralis</i>	Bone-Sided Sedge	0.5
	<i>Agrostis exarata</i>	Spike bentgrass	1
	<i>Danthonia californica</i>	California Oatgrass	2
	<i>Deschampsia cespitosa</i>	Tufted Hairgrass	1
	<i>Juncus tenuis</i>	Slender Rush	0.1
	<i>Achillea millefolium</i>	Western Yarrow	0.25
	<i>Epilobium densiflorum</i>	Spike Primrose	0.1
	<i>Grindelia integrifolia</i>	Willamette Gumweed	0.1
	<i>Lupinus rivularis</i>	Riverbank Lupine	0.1
	<i>Madia elegans</i>	Common Madia	0.3
	<i>Mimulus guttatus</i>	Yellow Monkeyflower	0.1
	<i>Plagiobothrys figuratus</i>	Fragrant Popcom Flower	0.1
	<i>Sidalcea campestris</i>	Checkermallow	0.5

Additional Stormwater Plants

These plants are planned to be used or may be used in limited areas near the Admin Building.

Stormwater Plants			
Code	Botanical Name	Common Name	Quantity
AST SUB	<i>Aster subspicatus</i>	Douglas Aster	1 Gal.
CAM LEI	<i>Camassia leichtlinii</i>	Great Camas	Corn
CAR OBN	<i>Carex obnupta</i>	Slough Sedge	Plug
COR MID	<i>Comus 'Midwinter Fire'</i>	Midwinter Fire Osier	1 Gal.
JUN TEN	<i>Juncus tenuis</i>	Spreading Rush	Plug
MAH COM	<i>Mahonia 'Compacta'</i>	Compact Oregon Grape	1 Gal.
MYR CAL	<i>Myrica californica</i>	Pacific Wax Myrtle	5 Gal.
PHY CAP	<i>Physocarpus capitatus</i>	Ninebark	1 Gal.
POL MUN	<i>Polysticum munitum</i>	Western Sword Fern	1 Gal.
SAL NAN	<i>Salix 'Nana'</i>	Purple Willow	5 Gal.
SPI TOR	<i>Spiraea 'Tor'</i>	Birchleaf Spirea	5 Gal.
DES GOL	<i>Deschampsia 'Goldtau'</i>	Gold Dew Tufted Hairgrass	Plug
CAM QUA	<i>Camassia quamash</i>	Camas	Corn
CAR DEN	<i>Carex densa</i>	Slough Sedge	Plug
COR KEL	<i>Comus 'Kelseyi'</i>	Kelsey's Dogwood	1 Gal.
IRI DOU	<i>Iris douglasii</i>	Douglas Iris	Corn
IRI TEN	<i>Iris tenax</i>	Pacific Coast Iris	Corn
MAH REP	<i>Mahonia repens</i>	Creeping Oregon Grape	1 Gal.
MAH SOF	<i>Mahonia 'Soft Caress'</i>	Soft Caress Mahonia	5 Gal.



Expires: 02/27/2023



Designed By	XXX	Program Mgr	XXX
Drawn By	XXX	Const Mgr	XXX
Checked By	XXX	Const Supvr	XXX
Project Mgr	XXX	Date	09/02/22

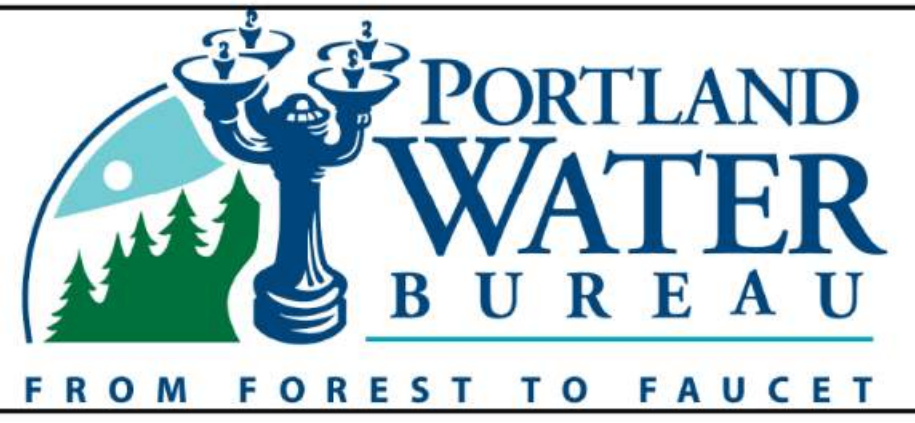

David W. Peters, Engineering Manager, PE No 16683



Bull Run Filtration Facility
 Land Use Plans
 Details
 Stormwater Planting

SAP Project No
W02229
 1/4 Section
 Sheet No
00-LU-404
14 of **18**

Exhibit A.212.n

Plot Date: 1-SEP-2022 02:27 User: stanpw11-pw-svc File: W02229_FF_00-LU-405.dgn Model: 00-LU-405 ColorTable: bw_jPlot.ctb DesignScript: PWB_PenTable.pen PlotScale: 0.0833333:1

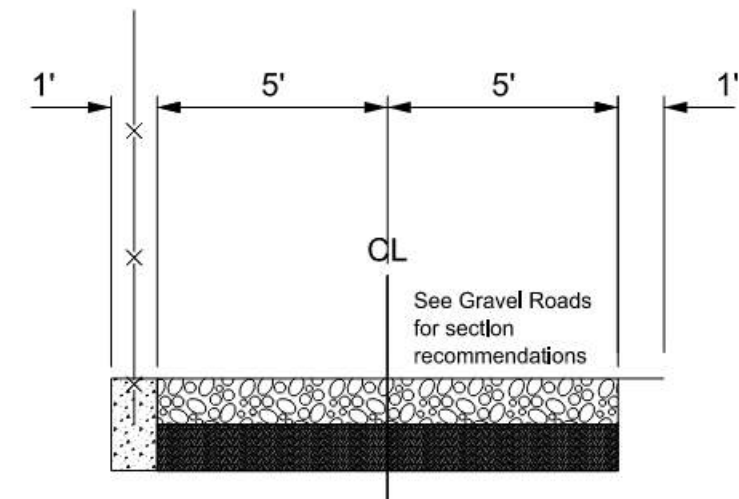

A Perimeter Road Typical Section
02-C-901 NTS

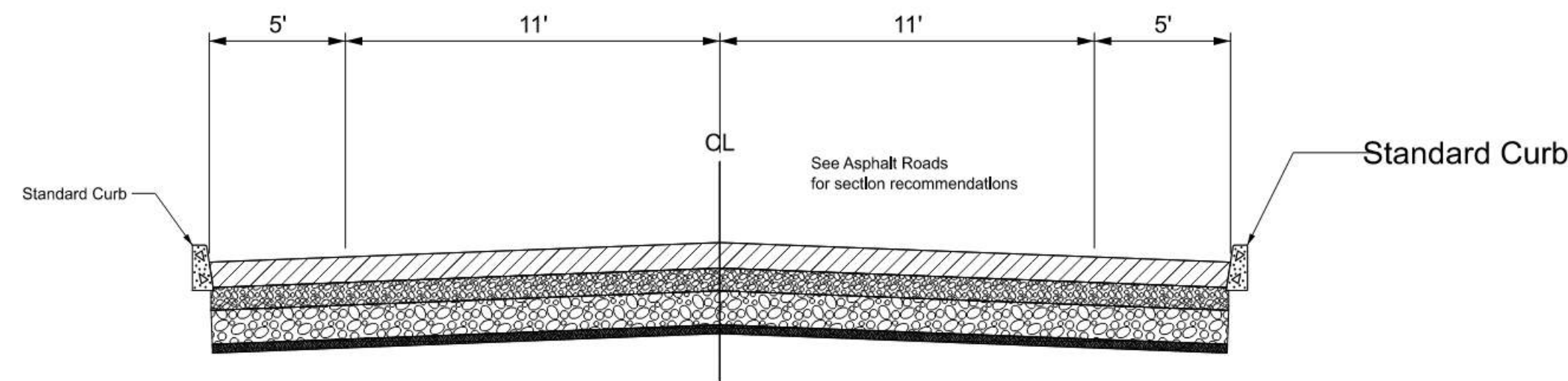

B Road A Typical Section
02-C-901 NTS
Road A
Sta "A" 0+00.00 - 7+09.08

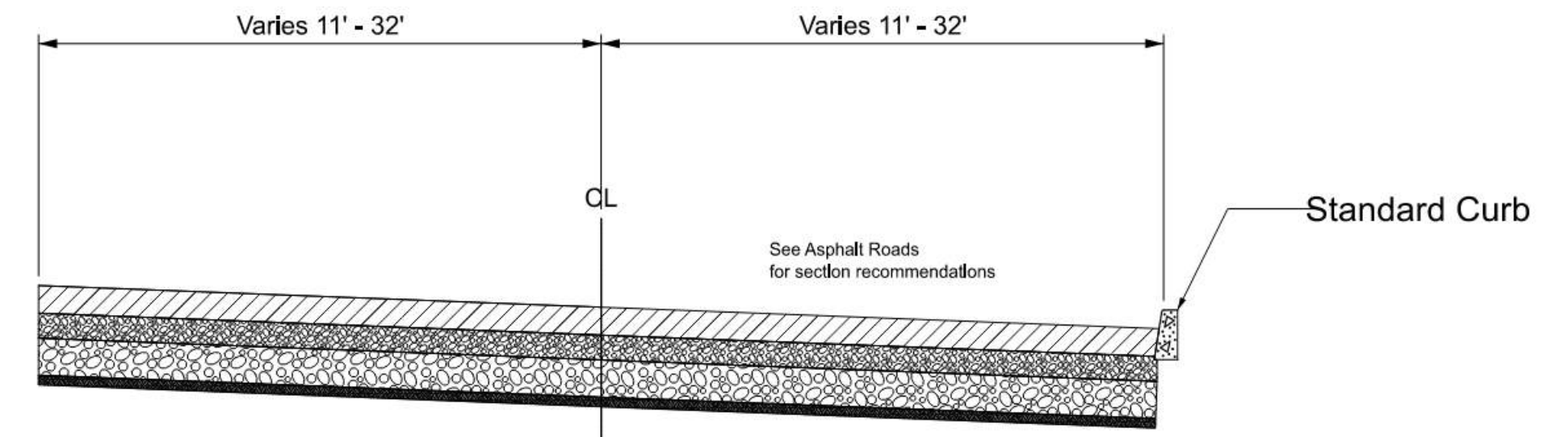

C Road A Typical Section
02-C-901 NTS
Road A
Sta "A" 7+09.08 - 13.42.49

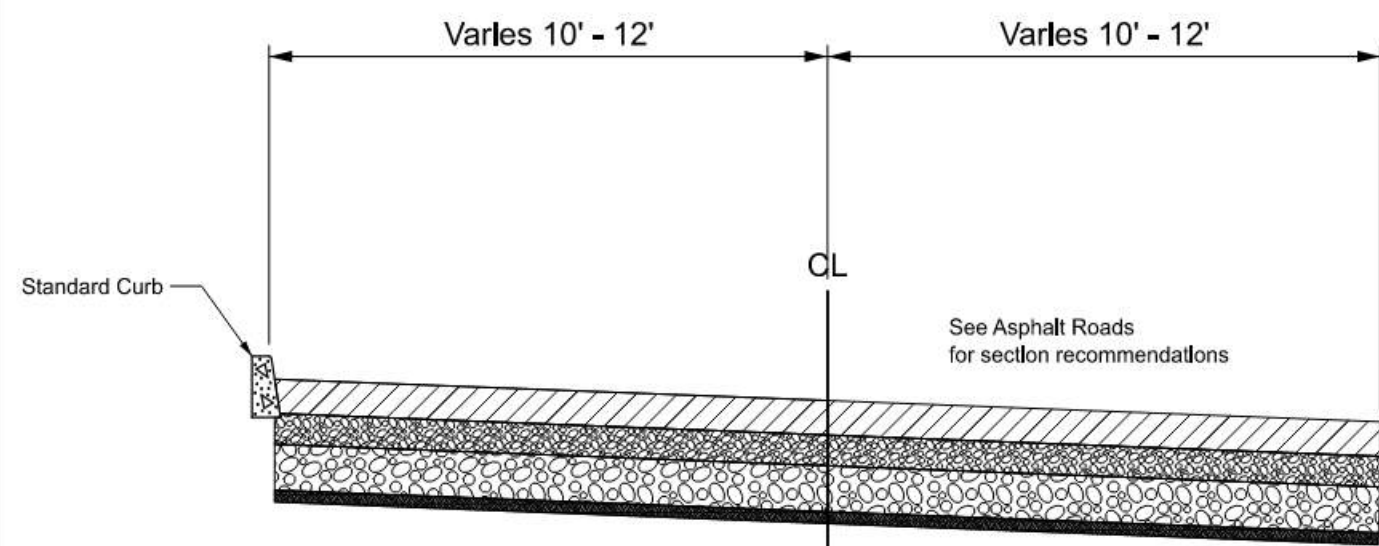

D Road B Typical Section
02-C-901 NTS
Road B
Sta "B" 0+00.00 - 4+39.76

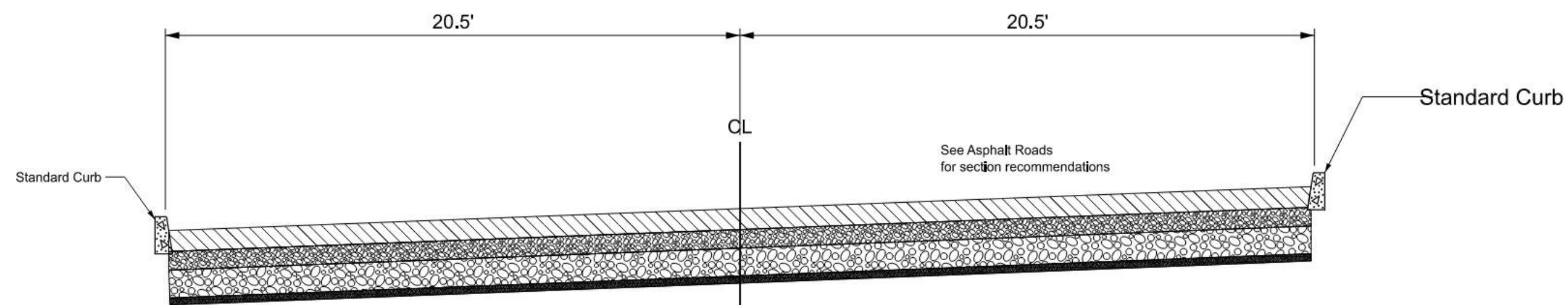

E Road C Typical Section
02-C-901 NTS
Road C
Sta "C" 3+13.87 - 7+27.64

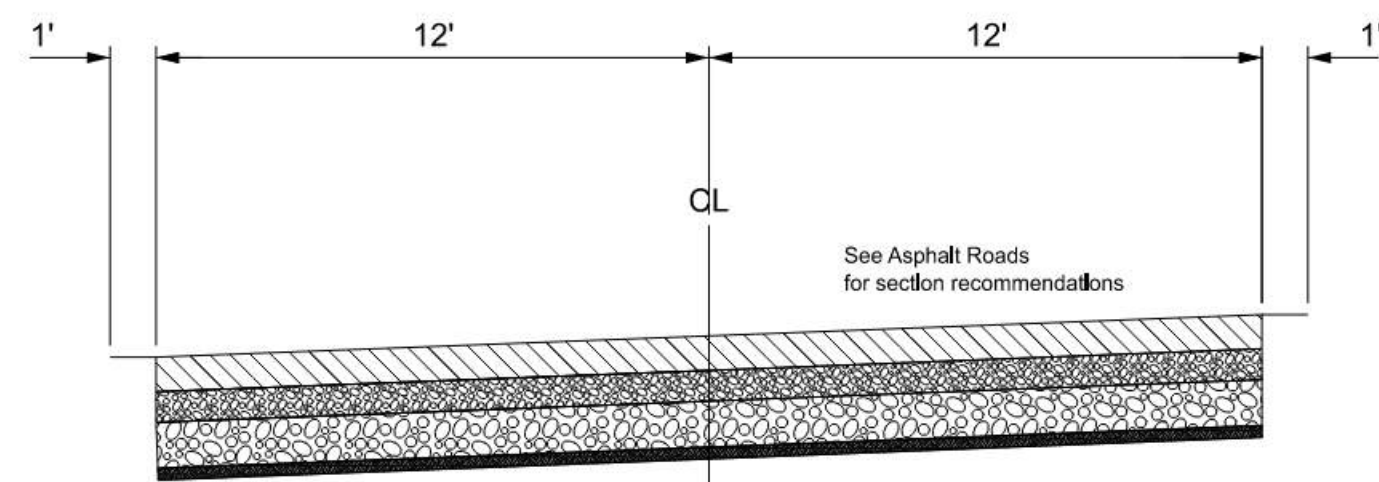

F 26" Road Typical Section
02-C-901 NTS
Road C, Road E, Road F
Sta "C2" 0+00.00 - 5+50.00
Sta "E" 0+00.00 - 6+24.20
Sta "F" 0+00.00 - 9+18.82

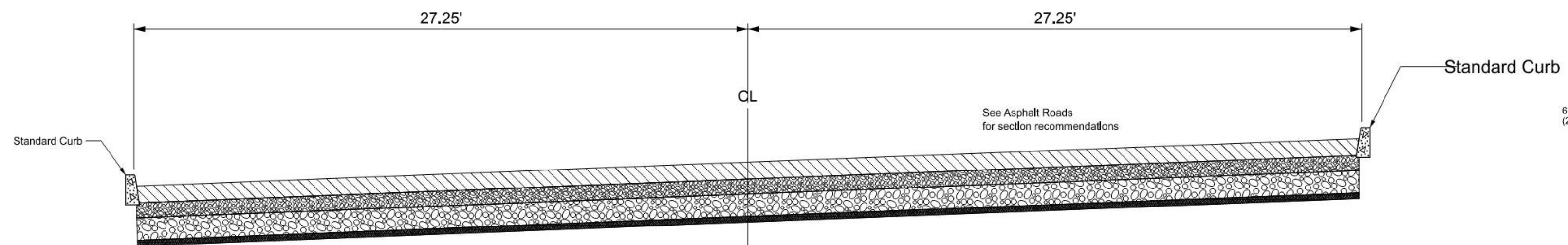

G Road D Typical Section
02-C-901 NTS
Road D
Sta "D" 1+46.52 - 5+93.63

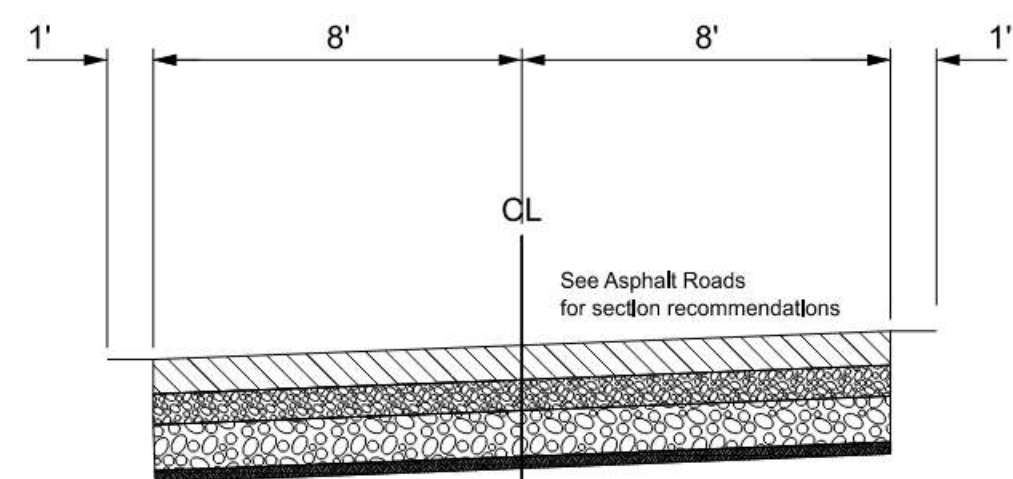

H Road H Typical Section
02-C-901 NTS
Road H
Sta "H" 0+00.00 - 20+80.52

General Sheet Notes

1. Prepare subgrade in accordance with the sections shown below. Choose one method to stabilize the subgrade for each road.
2. Asphalt design parameters per Table 10-3 on sheet 00-LU-406.

Asphalt Roads

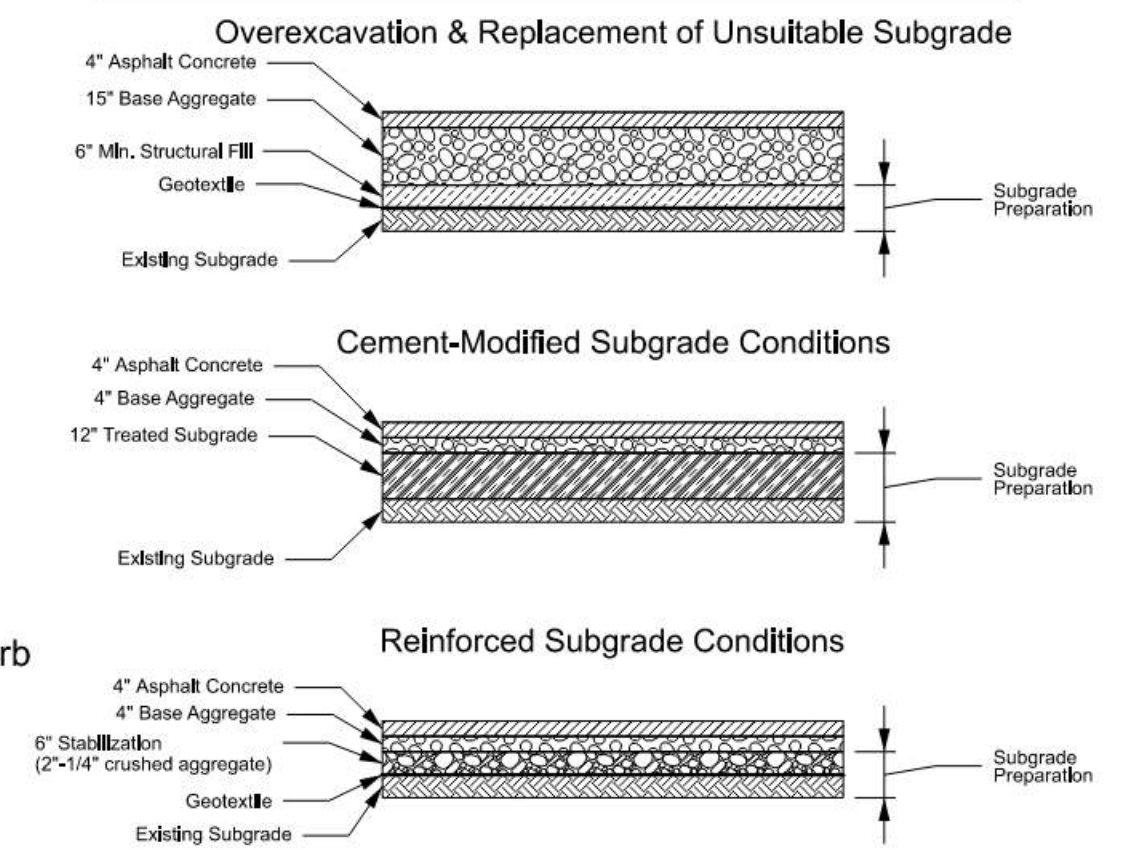

Gravel Roads

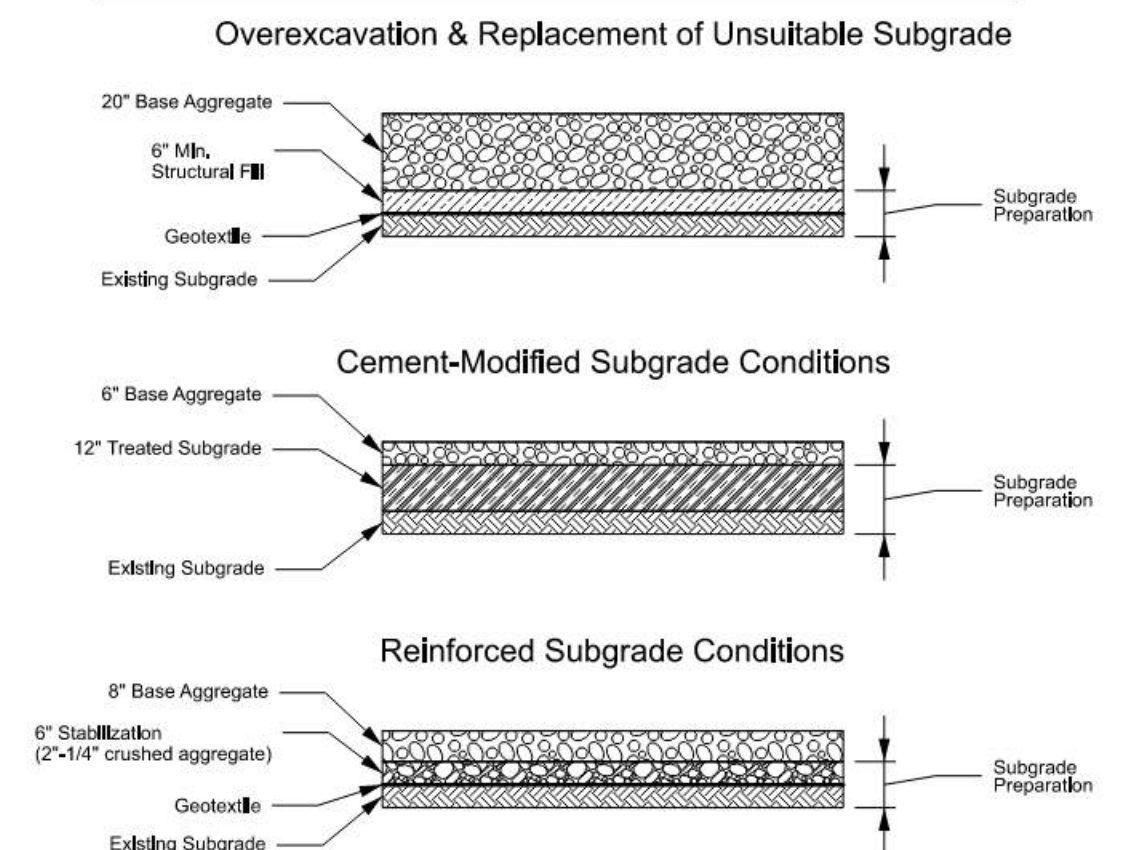

Legend:

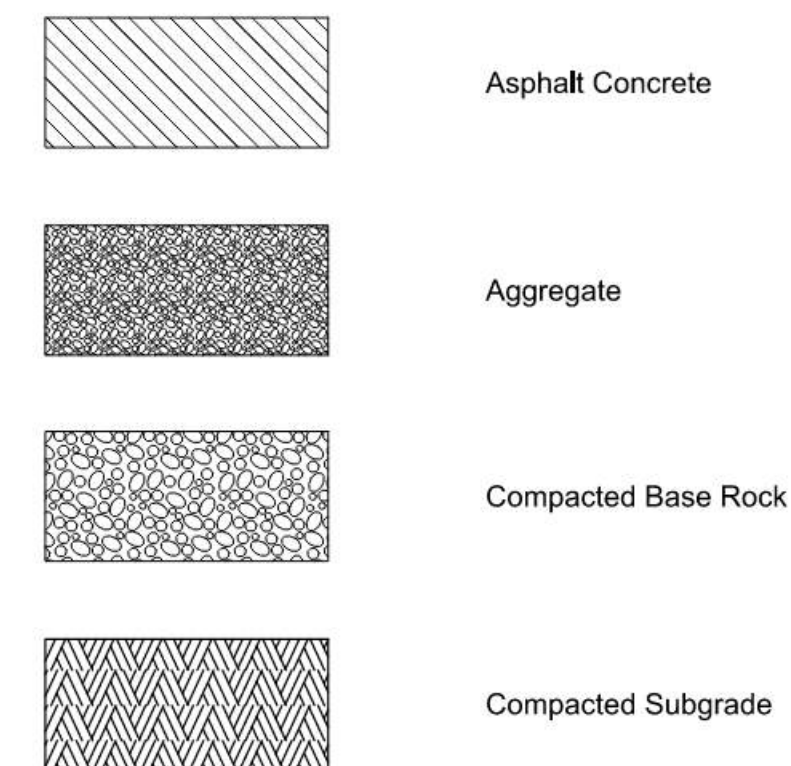

No	Date	Description	Appd
C	09/2022	Second Intermediate Design and BCOE Review - 90% Submittal	MRG
B	01/2022	Intermediate Design - 60% Submittal	MRG
A	07/2021	Initial Design - 30% Submittal	MRG
Revision			
Survey			



Designed By	Program Mgr
Drawn By	Const Mgr
Checked By	Const Supvr
Project Mgr	Date
	09/02/22

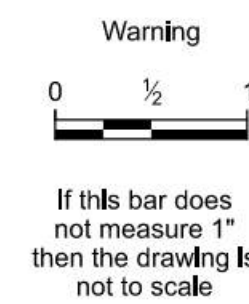

David W. Peters, Engineering Manager, PE No 16683



Bull Run Filtration Facility
Civil
Roadway Typical Sections

Exhibit A.212.o

SAP Project No
W02229
1/4 Section
3765 / 3766
Sheet No
00-LU-405
X of X

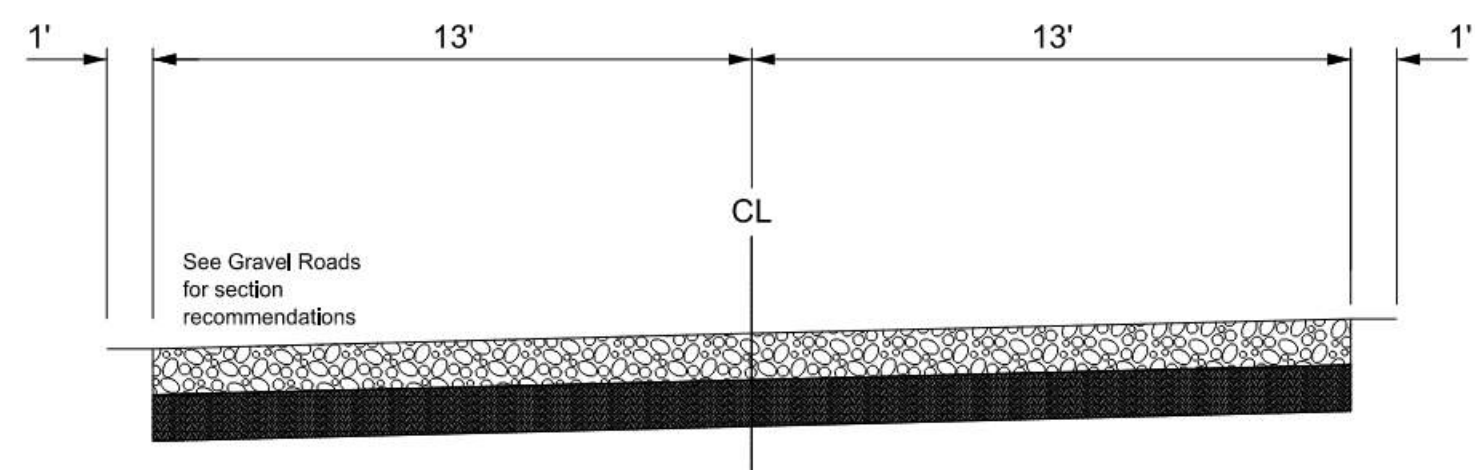

A Emergency Access
00-LU-406 NTS

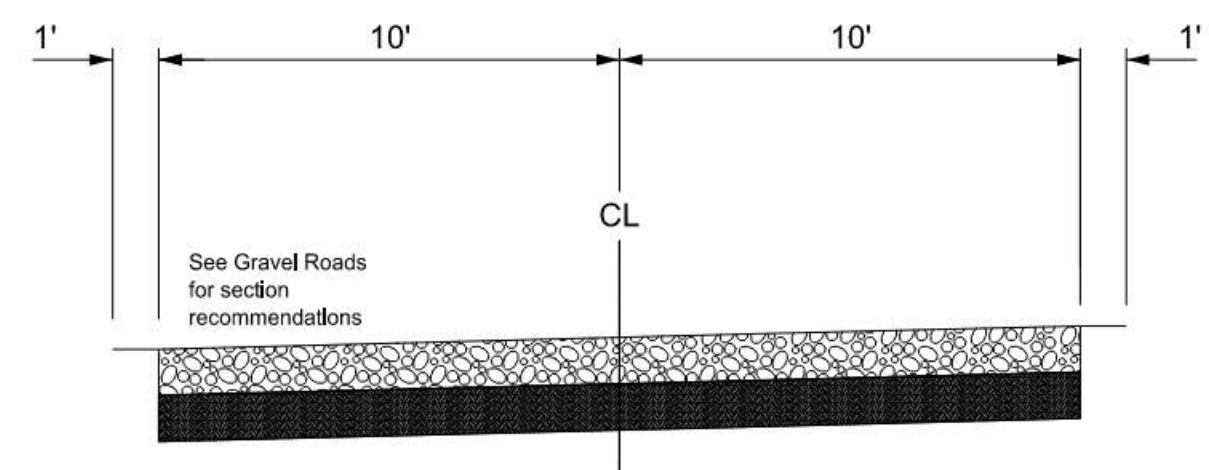

C Carpenter Lane
00-LU-406 NTS

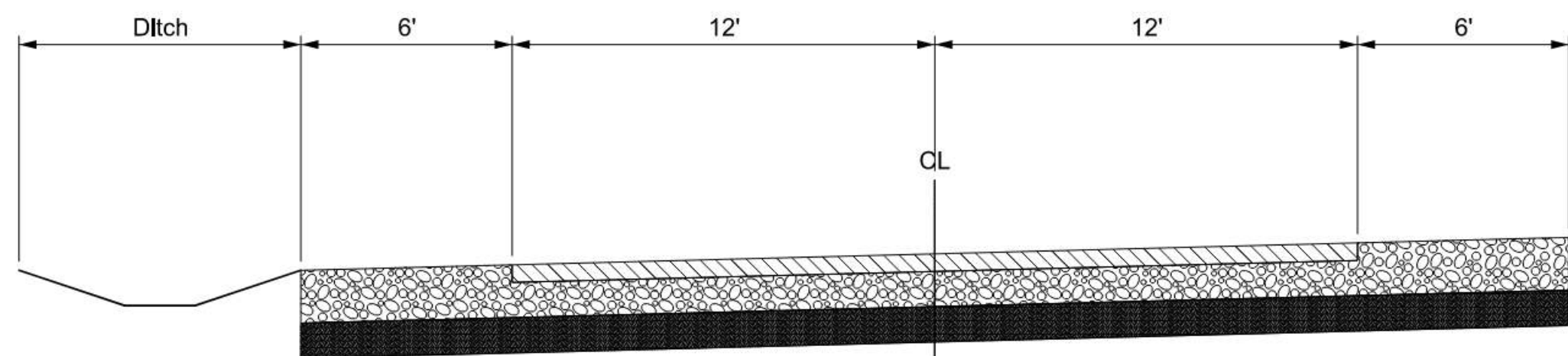

B Road I
00-LU-406 NTS

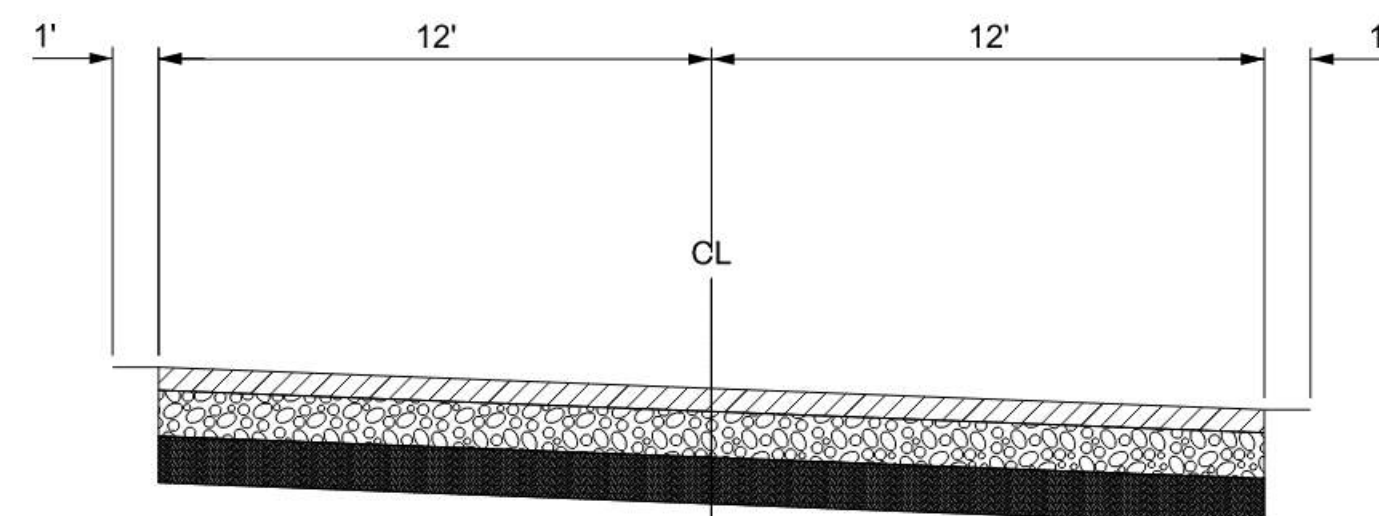

D Cottrell Rd
00-LU-406 NTS

Table 10-3. Asphalt and Gravel Road Design Parameters

Parameter	Value	Parameter	Value	
Pavement Design Life (years) ^a	20	Existing Subgrade Conditions - Fat Clay (CH), Lean Clay (CL), and Elastic Silt (MH)	3,300 ^e	
Growth Rate (%)	0			
Initial Serviceability ^a	4.2			
Terminal Serviceability ^a	2.5			
Standard Deviation ^a	0.49	Subgrade Resilient Modulus, M_R (psi)	Cement-Modified Subgrade ^d	22,500
Reliability (%) ^a	90		Reinforced Subgrade ^d	9,000
Drainage Coefficient - Asphalt ^a	1.0		Compacted Subgrade ^d	15,000
Drainage Coefficient - Aggregate Base ^a	1.0	Resilient Modulus - Aggregate Base (psi) ^a	20,000	
		Structural Coefficient - Asphalt ^a	0.42	
		Structural Coefficient - Aggregate Base ^a	0.10	
		Design Traffic (ESALs) ^a	41,000	

- a. Values based on guidelines presented in the 2019 ODOT Pavement Design Guide for flexible pavements.
- b. A 90% reliability value was selected to account for variations in traffic predictions and performance predictions to provide a predetermined level of assurance that pavement sections will survive the design life period (AASHTO, 1993).
- c. Existing subgrade conditions M_R value based on mean value minus one standard deviation from the results of the 12 DCP tests performed, as discussed in Section 10.2.2.
- d. Cement-modified subgrade consists of a 12-inch subgrade treatment depth, amended with 8 percent Portland Cement (by weight). The cement-modified subgrade should have a minimum 7-day compressive strength of 100 psi and have a minimum in-place density of 95% of maximum dry density per Modified Proctor test. M_R value based on a conservative 50% improvement factor of subgrade conditions (Hopkins, et al. 2004).
- e. Reinforced subgrade consists of a reinforcement & separation geotextile overlain by a minimum 6-inch subgrade stabilization layer in accordance with Section 9.5. M_R value recommended by geosynthetic manufacturer's engineer.
- f. M_R value for compacted subgrade conditions is based on results of CBR tests performed on bulk samples. In-place density testing must be performed to verify that 95% of maximum dry density per Modified Proctor test has been achieved.
- g. Our ESAL calculations assumed an average daily traffic (ADT) of 100 vehicles consisting of: two WB-50 trucks (Class 9, 5-axle tractor semitrailer truck), 44 passenger cars, 44 pickup trucks/vans, 2-axle, 6-tire (dual rear tires) trucks.

General Sheet Notes

1. Prepare subgrade in accordance with the sections shown below. Choose one method to stabilize the subgrade for each road.
2. Asphalt design parameters per Table 10-3 on sheet 00-LU-406.

Asphalt Roads

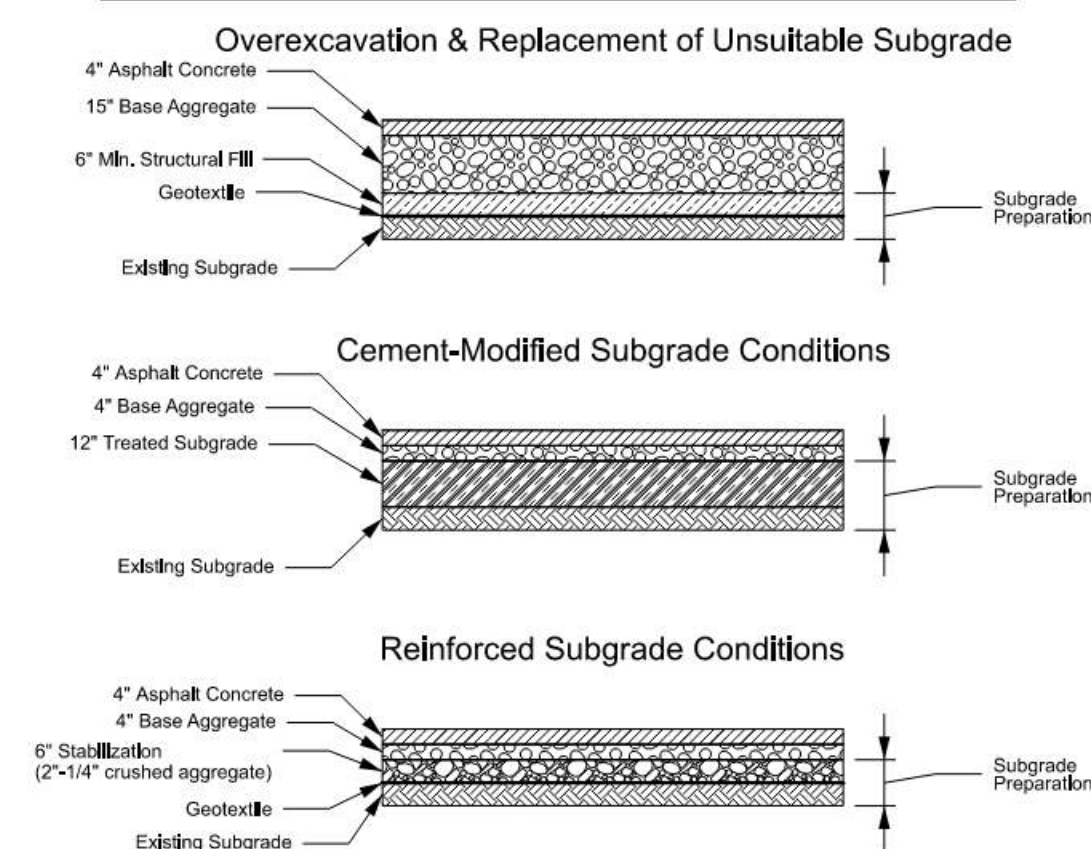

Gravel Roads

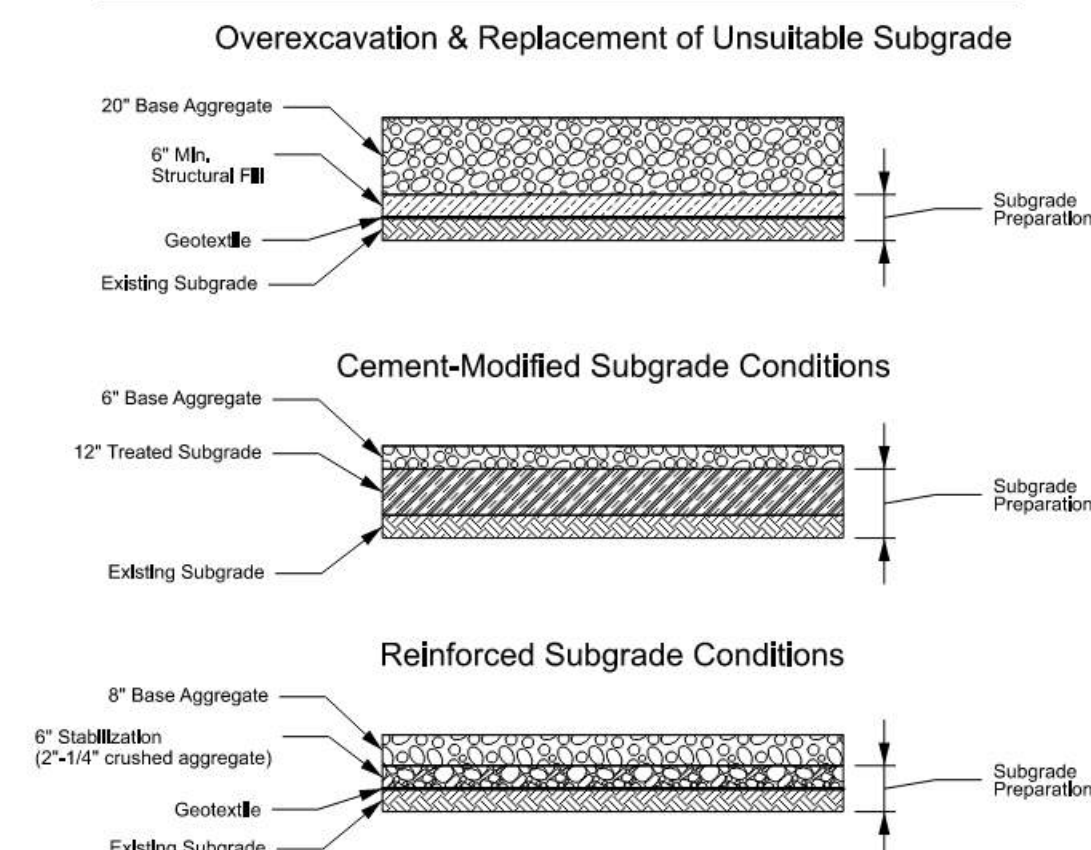

Legend:

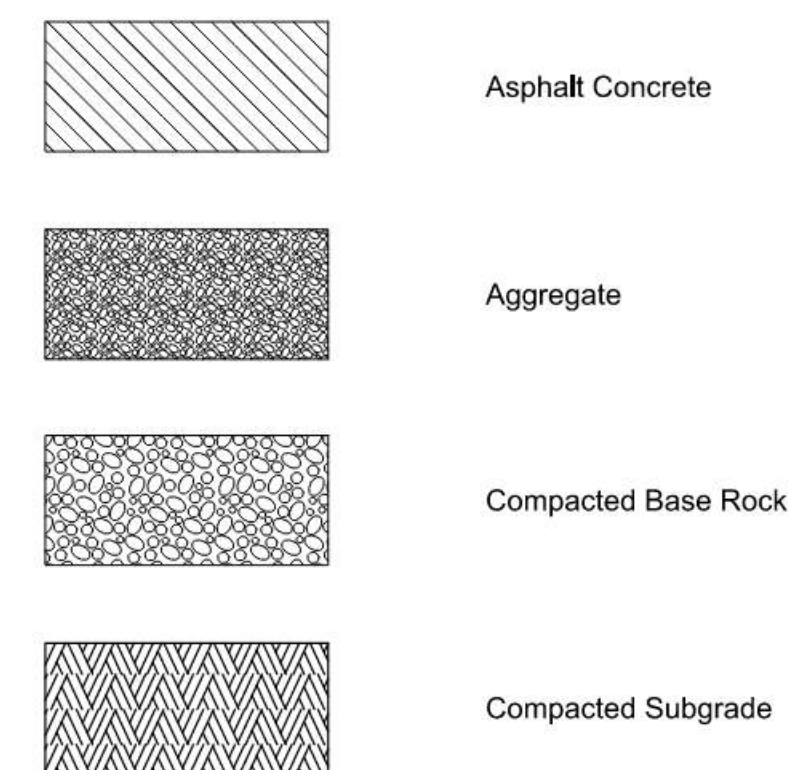

Designed By	Program Mgr	DWP
Drawn By	Const Mgr	TG
Checked By	Const Supvr	RM
Project Mgr	Date	09/02/22

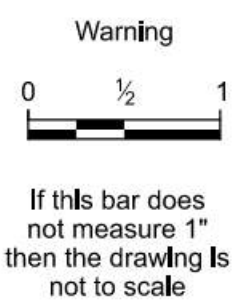

David W. Peters, Engineering Manager, PE No 16683



Bull Run Filtration Facility
Civil
Roadway Typical Sections -2

Exhibit A.212.p

SAP Project No
W02229
1/4 Section
3765 / 3766
Sheet No
00-LU-406
X of X

Plot Date: 1-SEP-2022 02:27 User: stanpw11-pwsvic Files: W02229_FF_00-LU-406.dgn Model: 00-LU-406 ColorTable: bw_plot.ctb DesignScript: PWB_PenTable.pen PlotScale: 0.0833333:1

No	Date	Description	Appd
C	09/2022	Second Intermediate Design and BCOE Review - 90% Submittal	MRG
B	01/2022	Intermediate Design - 60% Submittal	MRG
A	07/2021	Initial Design - 30% Submittal	MRG
Revision			
Survey			

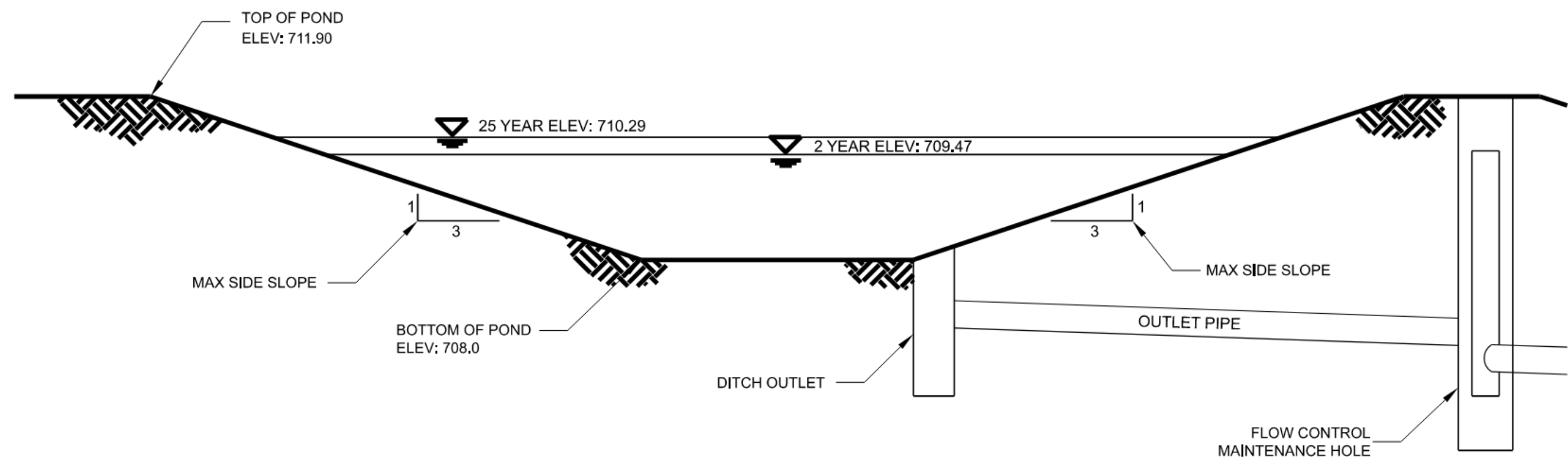

A Pond A
 10-LU-407 N.T.S.

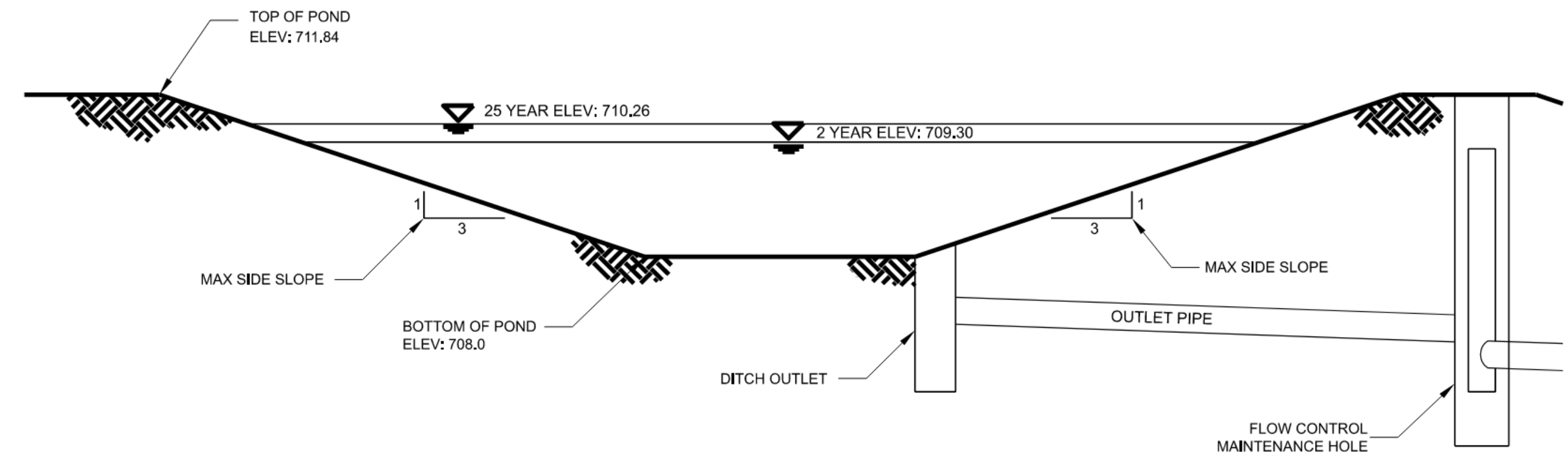

B Pond B
 10-LU-407 N.T.S.

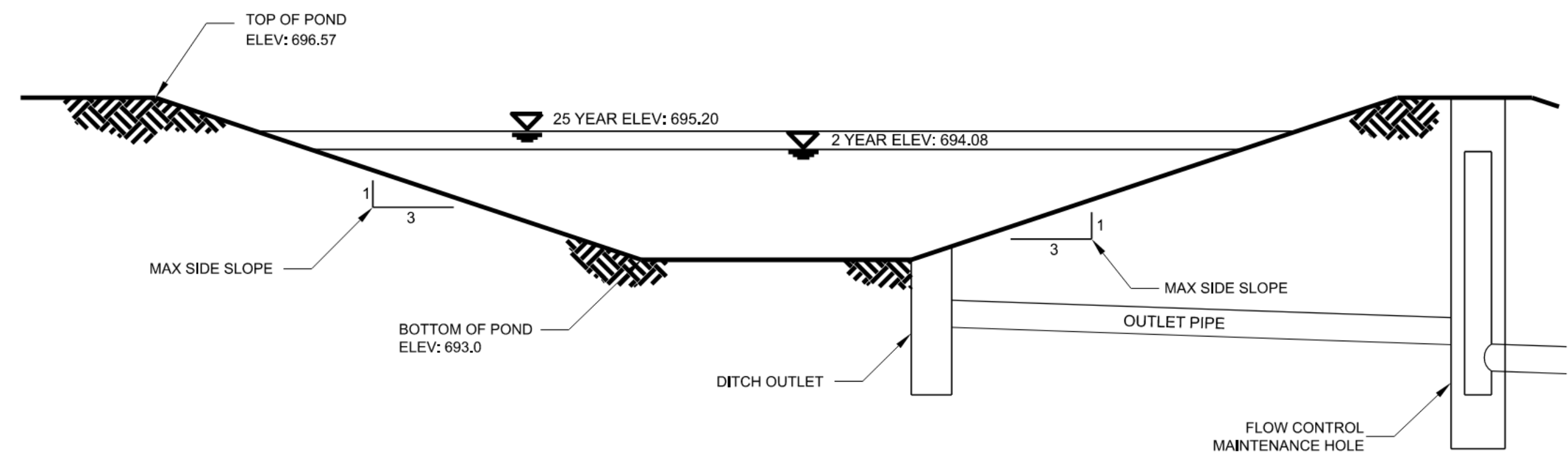

D Pond D
 10-LU-407 N.T.S.

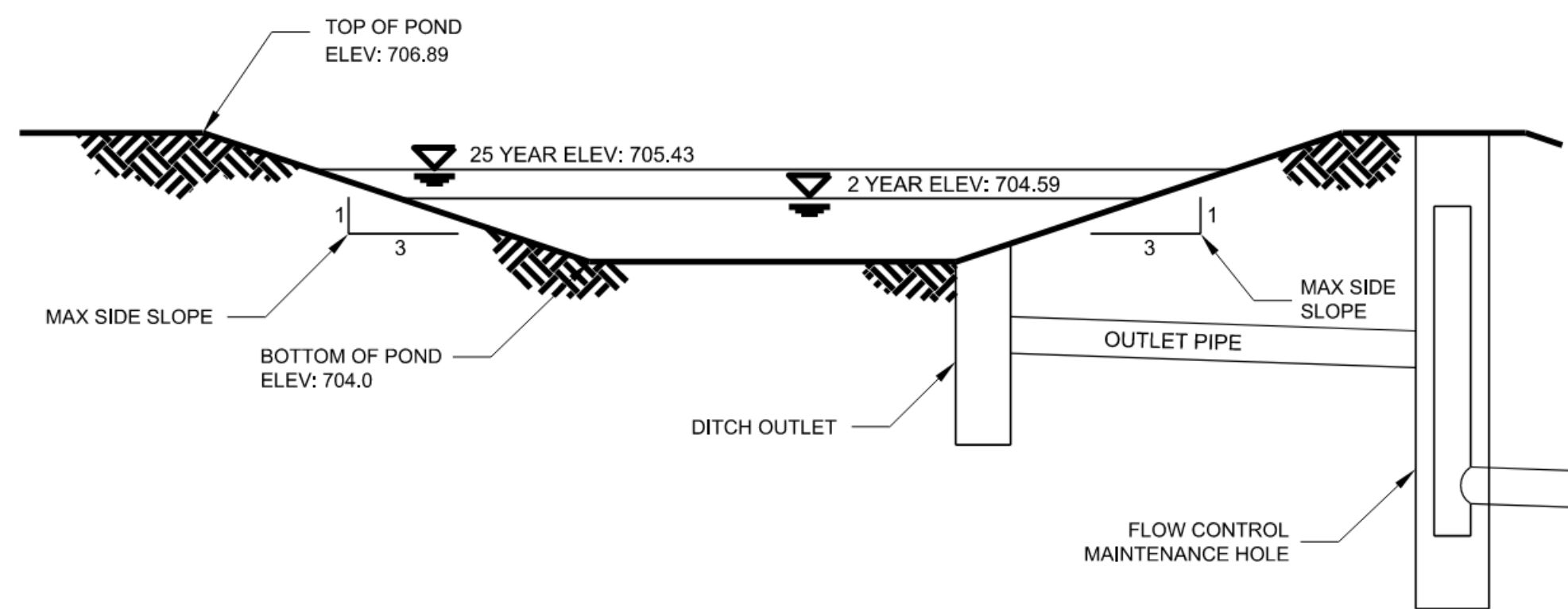

C Pond C
 10-LU-407 N.T.S.

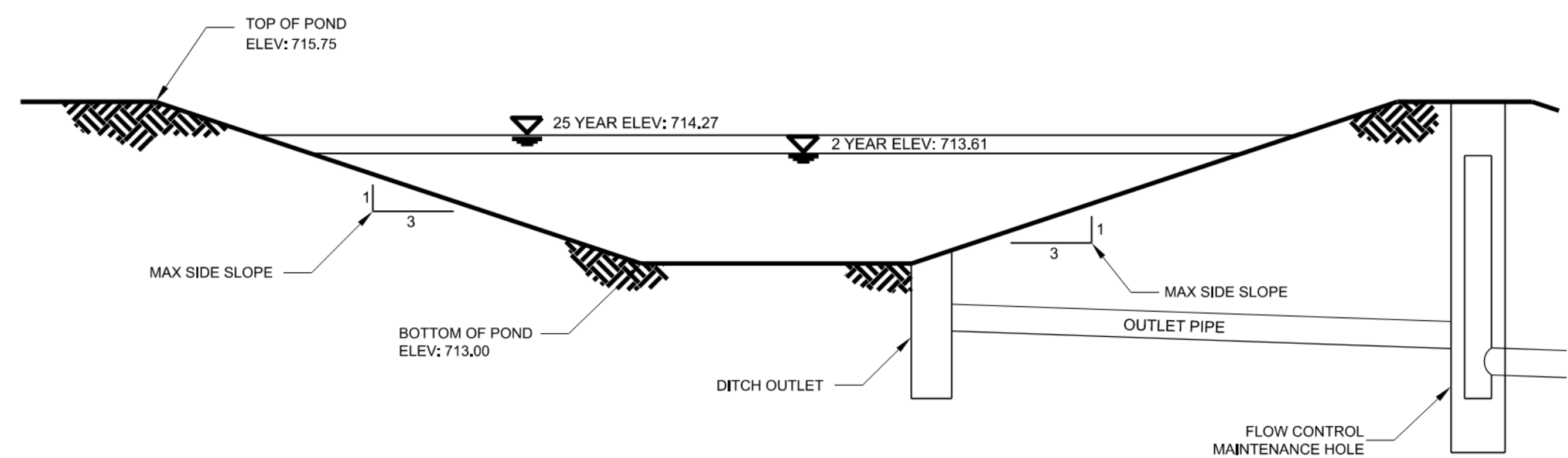

E Pond E
 10-LU-407 N.T.S.

\$\$\$\$\$FILENAME\$\$\$\$\$
 \$\$\$USER\$\$\$\$\$
 \$\$\$DATE\$\$\$\$\$

No	Date	Description	Appd
C	09/2022	Second Intermediate Design and BCOE Review - 90% Submittal	MRG
B	01/2022	Intermediate Design - 60% Submittal	MRG
A	07/2021	Initial Design - 30% Submittal	MRG
Revision			
Survey			



Designed By	JSL	Program Mgr	DWP
Drawn By	KRF	Const Mgr	TG
Checked By	LCS	Const Supvr	RM
Project Mgr	MRG	Date	09/02/22

Warning
 0 1/2 1
 If this bar does not measure 1" then the drawing is not to scale



David W. Peters, Engineering Manager, PE No 16683



Bull Run Filtration Facility
 Civil
 Pond Section
 Details

Exhibit A.212.q

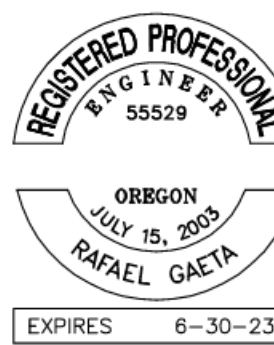

SAP Project No	W02229
1/4 Section	3765 / 3766
Sheet No	00-LU-407
of	

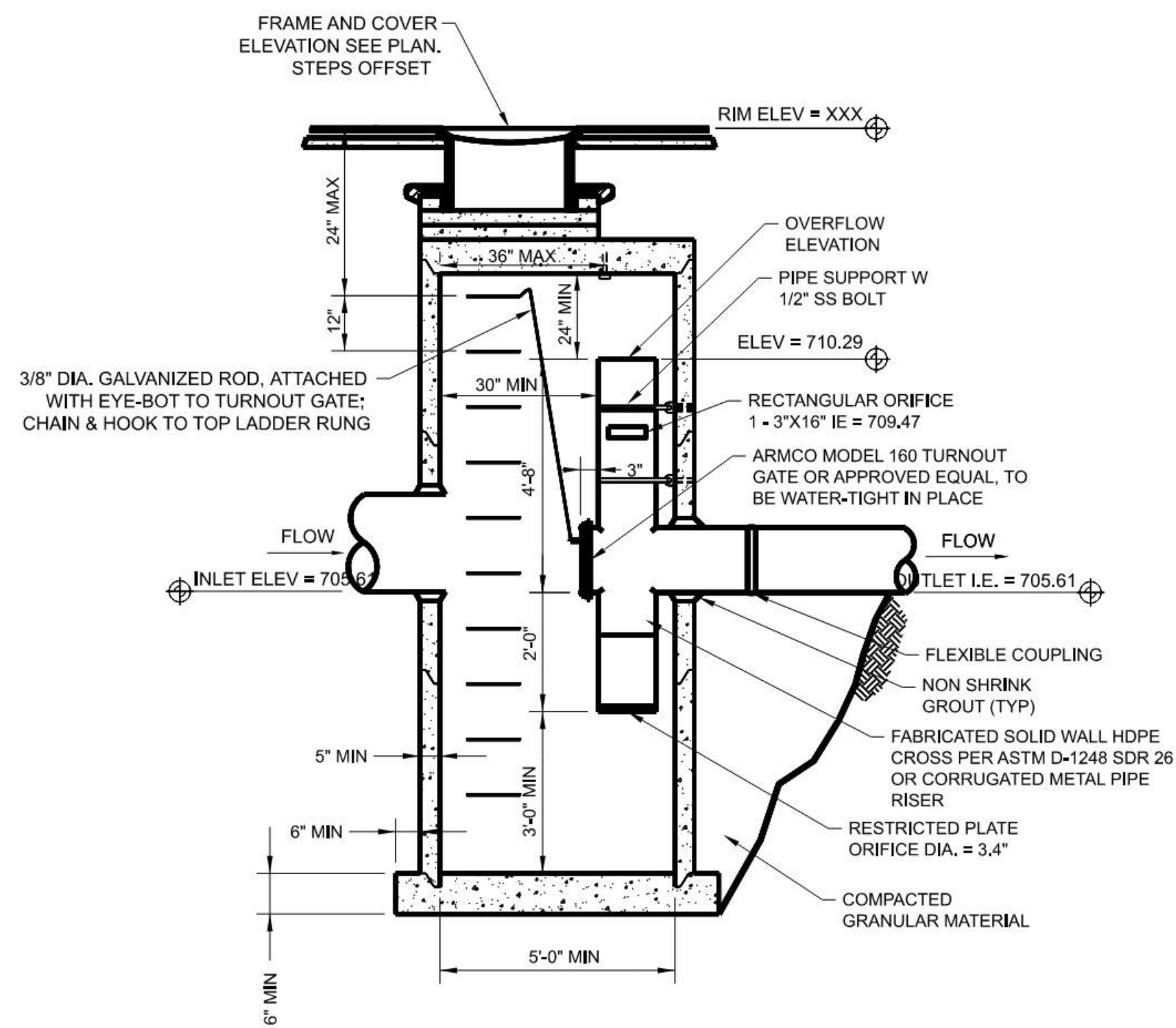

A Flow Control Maintenance Hole - Pond A
10-LU-408 N.T.S.

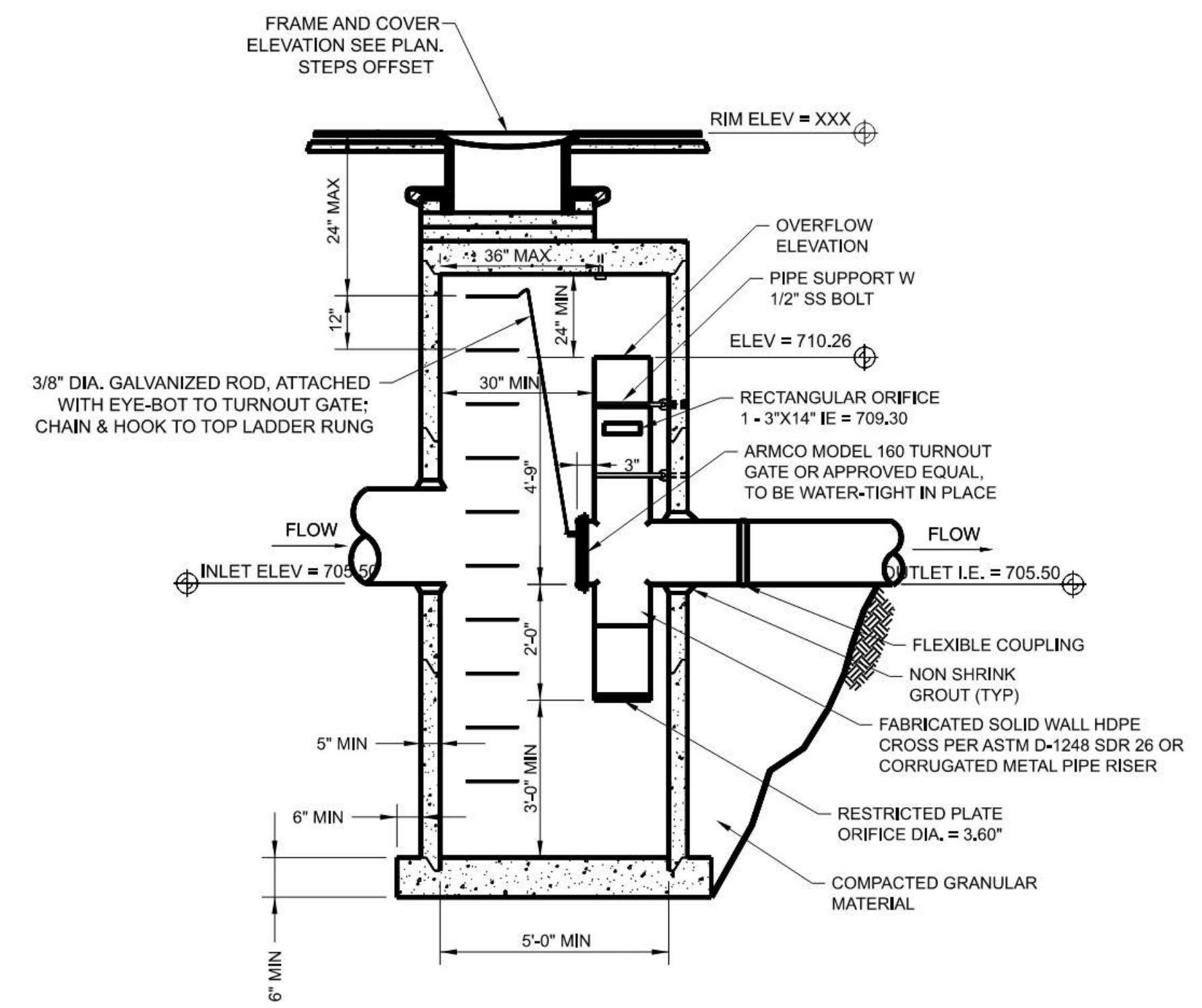

B Flow Control Maintenance Hole - Pond B
10-LU-408 N.T.S.

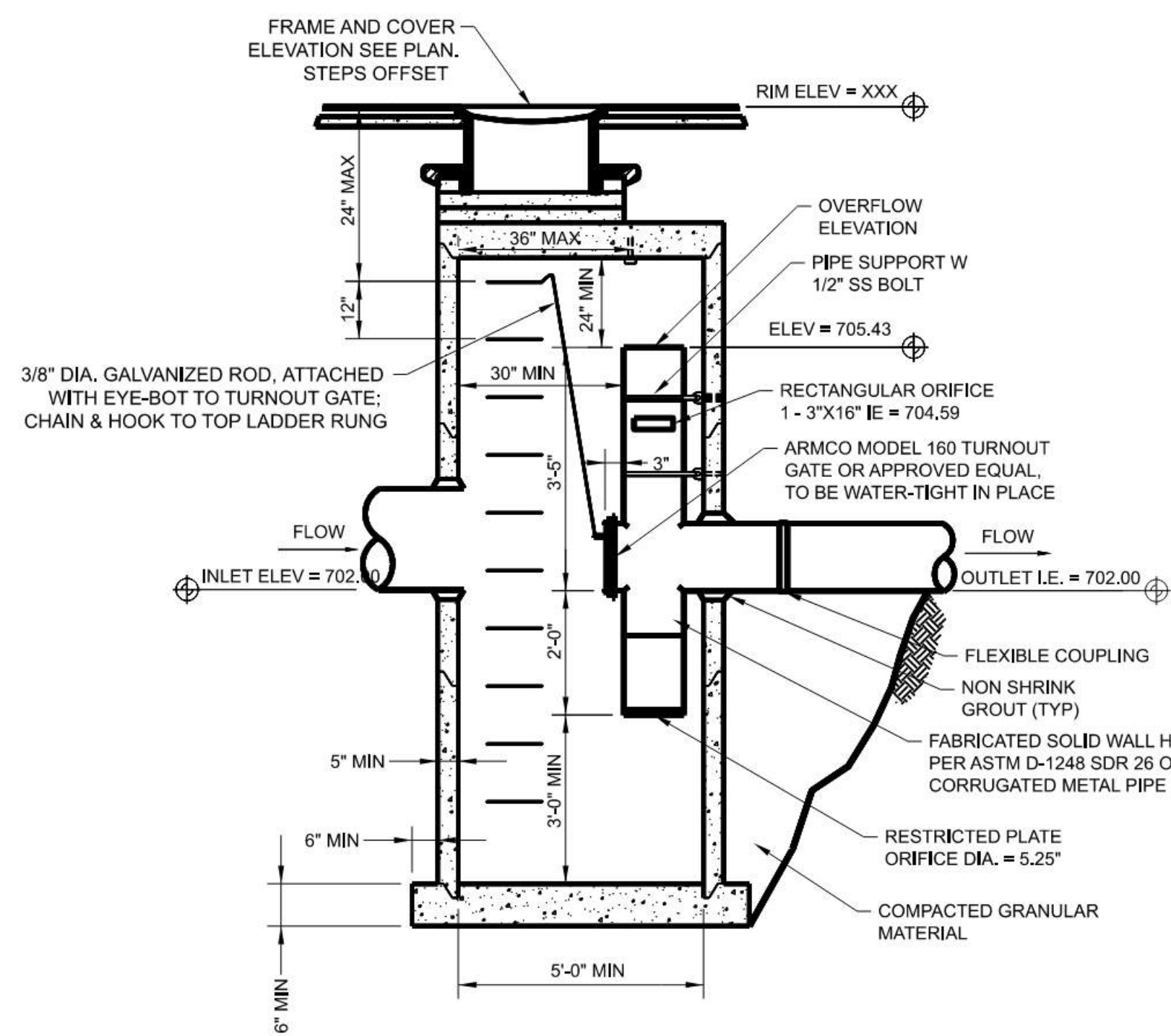

C Flow Control Maintenance Hole - Pond C
10-LU-408 N.T.S.

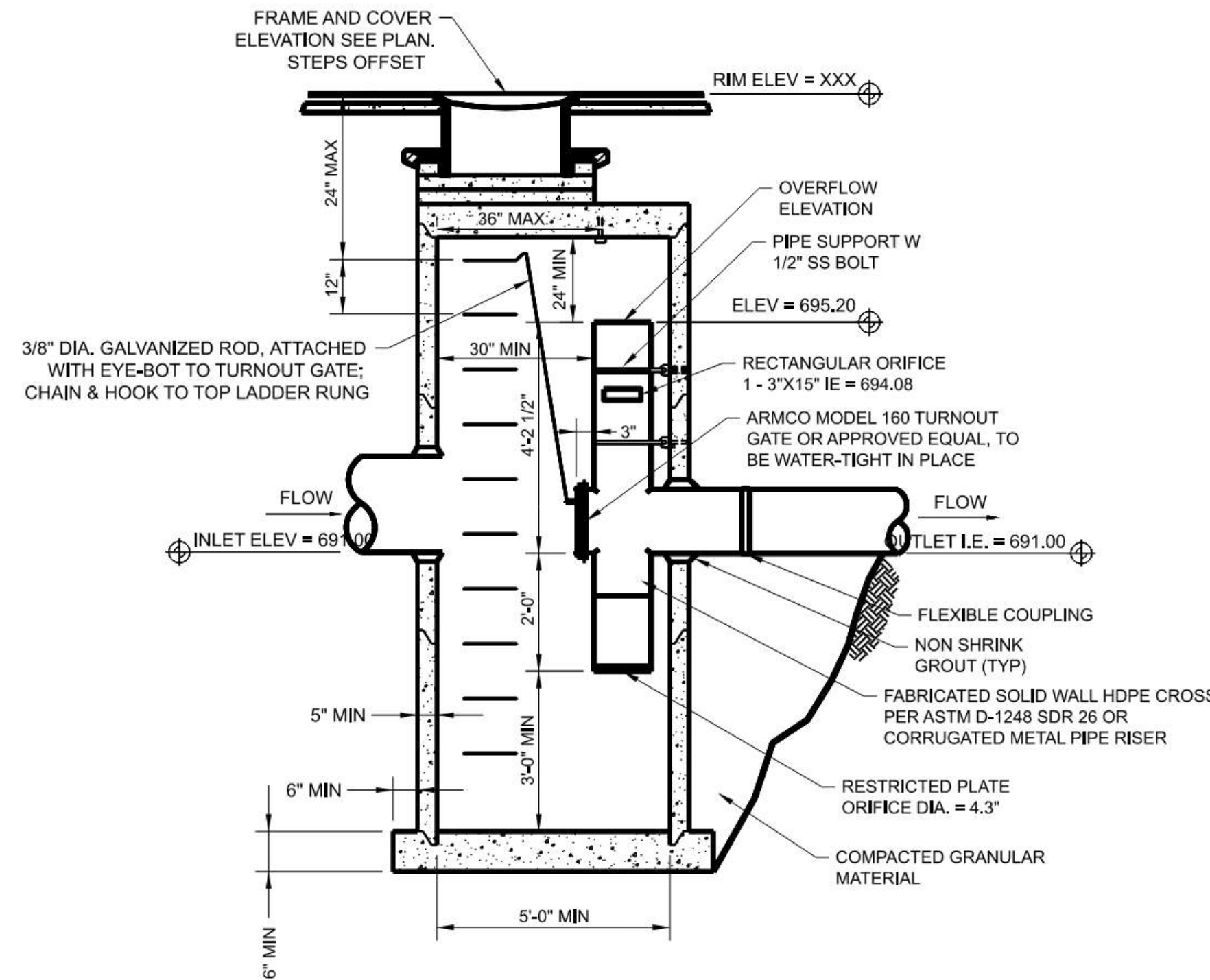

D Flow Control Maintenance Hole - Pond D
10-LU-408 N.T.S.

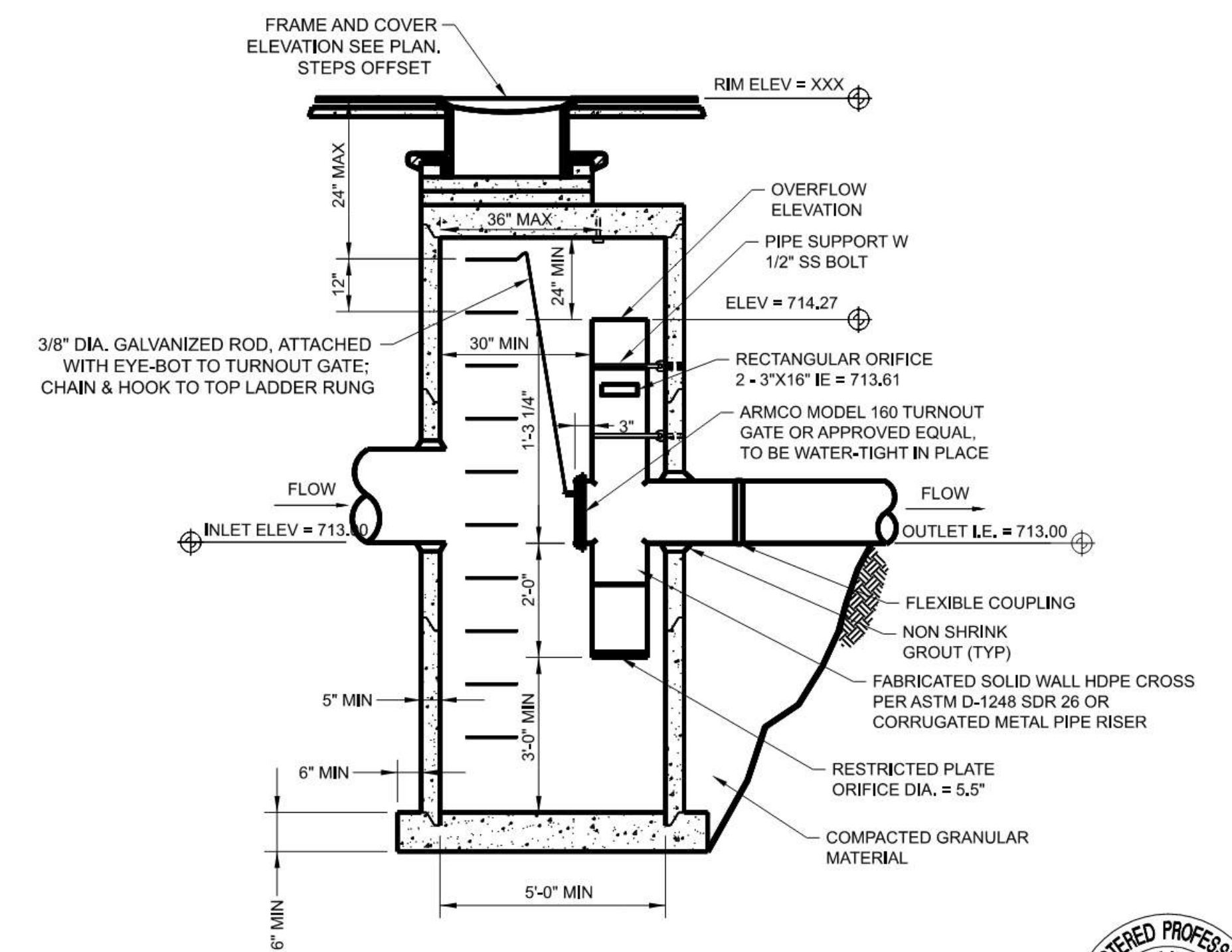

E Flow Control Maintenance Hole - Pond E
10-LU-408 N.T.S.

\$\$\$\$\$FILENAME\$\$\$\$\$
\$\$\$\$\$USER\$\$\$\$\$
\$\$\$\$\$DATE\$\$\$\$\$

No	Date	Description	Appd
C	09/2022	Second Intermediate Design and BCOE Review - 90% Submittal	MRG
B	01/2022	Intermediate Design - 60% Submittal	MRG
A	07/2021	Initial Design - 30% Submittal	MRG
No			



Designed By	KRF	Program Mgr	MRK
Drawn By	KRF	Const Mgr	MRK
Checked By	LCS	Const Supvr	MRK
Project Mgr	MRK	Date	09/02/22

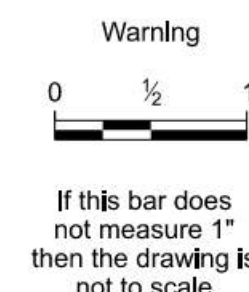

David W. Peters, Engineering Manager, PE No 16683



Bull Run Filtration Facility
Civil
Flow Control Manhole
Details

Exhibit A.212.r



SAP Project No	W02229
1/4 Section	3765 / 3766
Sheet No	00-LU-408
of	

Individual Plants

Managed Landscape Areas		
Botanical Name	Common Name	Plant Size
Trees		
<i>Alnus rhombifolia</i>	White Alder	1.5" Cal.
<i>Calocedrus decurrens</i>	Incense-Cedar	5' Height
<i>Nyssa sylvatica</i>	Tupelo	1.5" Cal.
<i>Pinus contorta</i> var. <i>contorta</i>	Shore Pine	5' Height
<i>Pinus ponderosa</i> var. <i>benthamiana</i>	Pacific Ponderosa	5' Height
<i>Pseudotsuga menziesii</i>	Douglas-fir	1.5" Cal.
<i>Quercus garryana</i>	Oregon White Oak	1.5" Cal.
<i>Quercus garryana</i>	Oregon White Oak	2" Cal.
<i>Rhamnus purshinana</i>	Cascara	1.5" Cal.
<i>Thuja 'Hogan'</i>	Hogan Western Red Cedar	8' Height
<i>Thuja plicata</i>	Western Red Cedar	5' Height
<i>Thuja plicata</i>	Western Red Cedar	8' Height
Sub-Trees (10-15')		
<i>Acer circinatum</i>	Vine Maple	15 Gal.
<i>Amelanchier alnifolia</i>	Wester Service Berry	15 Gal.
Large Shrubs (5-10')		
<i>Garrya elliptica</i>	Silk Tassel Tree	5 Gal.
<i>Myrica californica</i>	Pacific Wax Myrtle	5 Gal.
<i>Rubus parviflorus</i>	Thimbleberry	1 Gal.
<i>Viburnum trilobum</i>	American Cranberry	1 Gal.
Small Shrubs (2' - 5')		
<i>Cornus 'Kelsey'</i>	Kelsey's Dogwood	1 Gal.
<i>Mahonia aquifolium 'Compacta'</i>	Compact Oregon Grape	1 Gal.
<i>Mahonia nervosa</i>	Cascade Oregon Grape	1 Gal.
<i>Mahonia 'Soft Caress'</i>	Soft Caress Mahonia	5 Gal.
<i>Philadelphus lewisii 'Snow Dwarf'</i>	Dwarf Mockorange	1 Gal.
<i>Polystichum munitum</i>	Western Sword Fern	5 Gal.
<i>Spiraea betulifolia</i> var. <i>'Tor'</i>	Birchleaf Spirea	1 Gal.
<i>Vaccinium ovatum</i>	Evergreen Huckleberry	5 Gal.
Herbaceous (perennials, ferns, grasses)		
<i>Achillea 'Moonshine'</i>	Moonshine Yarrow	1 Gal.
<i>Aesclepias speciosus</i>	Milkweed	1 Gal.
<i>Aquilegia columbiana</i>	Columbine	1 Gal.
<i>Calamagrostis nutkatensis</i>	Pacific Reedgrass	1 Gal.
<i>Deschampsia 'Goldtau'</i>	Gold Dew Tufted Hairgrass	1 Gal.
<i>Helleborus argutifolia</i>	Corsican Hellebore	1 Gal.
<i>Iris douglasii</i>	Douglas Iris	1 Gal.
<i>Lupinus polyphyllus</i>	Big-Leaf Lupine	1 Gal.
<i>Sidalcea campestris</i>	Checker Mallow	1 Gal.
<i>Tellima grandiflora</i>	Fringecup	1 Gal.
Groundcover (12" or less)		
<i>Arctostaphylos 'Vancouver Jade'</i>	Vancouver Jade Bearberry	1 Gal.
<i>Carex flacca</i>	Grey Sedge	1 Gal.
<i>Fragaria chiloensis</i>	Beach Strawberry	1 Gal.
<i>Mahonia repens</i>	Cascade Oregon Grape	1 Gal.
<i>Sedum spathulifolium</i>	broadleaf sedum	1 Gal.
<i>Sedum oregonum</i>	oregon sedum	1 Gal.
Unmanaged Landscape Areas		
Botanical Name	Common Name	Plant Size
<i>Pinus contorta</i> var. <i>contorta</i>	Shore Pine	5' Height
<i>Pinus ponderosa</i> var. <i>willamettensis</i>	Willamette Valley Ponderosa Pine	5' Height
<i>Pseudotsuga menziesii</i>	Douglas Fir	5' Height
<i>Quercus garryana</i>	Oregon Oak	2" Cal.

Groundcover Mix - See sheet 00-LU-410 for layout details

Extended Area Groundcover				
Legend	Botanical Name	Common Name	Plant Size	% Composition
[Pattern]	<i>Arctostaphylos 'Vancouver Jade'</i>	Vancouver Jade Bearberry	1 Gal.	33%
[Pattern]	<i>Carex flacca</i>	Grey Sedge	1 Gal.	33%
[Pattern]	<i>Fragaria chiloensis</i>	Beach Strawberry	1 Gal.	34%

Screening Planting Mixes - See sheet 00-LU-410 for layout details

Screening Mix - Forested				
Legend	Botanical Name	Common Name	Plant Size	% Composition
Trees				
[Pattern]	<i>Abies grandis</i>	Grand Fir	3' Ht. Bareroot	15%
[Pattern]	<i>Acer macrophyllum</i>	Bigleaf Maple	1.5" Cal. Bareroot	5%
[Pattern]	<i>Calocedrus decurrens</i>	Incense Cedar	2" Ht. Bareroot	15%
[Pattern]	<i>Larix occidentalis</i>	Western Larch	3' Ht. Bareroot	5%
[Pattern]	<i>Pinus ponderosa</i>	Ponderosa Pine	3' Ht. Bareroot	10%
[Pattern]	<i>Pseudotsuga menziesii</i>	Douglas Fir	3' Ht. Bareroot	5%
[Pattern]	<i>Rhamnus purshiana</i>	Cascara	3' Ht. Bareroot	5%
[Pattern]	<i>Salix scouleriana</i>	Scouler's Willow	3' Ht. Bareroot	5%
Shrubs				
[Pattern]	<i>Mahonia aquifolium</i>	Tall Oregon Grape	Bareroot	15%
[Pattern]	<i>Oemleria ceraciformis</i>	Osoberry	Bareroot	5%
[Pattern]	<i>Polystichum munitum</i>	Swordfern	Bareroot	5%
[Pattern]	<i>Rubus parviflorus</i>	Thimbleberry	Bareroot	5%
[Pattern]	<i>Symphoricarpos albus</i>	Snowberry	Bareroot	5%

Screening Mix - Shrubby Unirrigated				
Legend	Botanical Name	Common Name	Plant Size	% Composition
Trees				
[Pattern]	<i>Cornus nuttallii</i>	Pacific Dogwood	1/2" Bareroot	5%
[Pattern]	<i>Pinus contorta</i> var. <i>contorta</i>	Shore Pine	1/2" Bareroot	10%
Shrubs				
[Pattern]	<i>Amelanchier alnifolia</i>	Serviceberry	1 Gal.	5%
[Pattern]	<i>Corylus cornuta</i> var. <i>californica</i>	Western Hazelnut	1 Gal.	5%
[Pattern]	<i>Holodiscus discolor</i>	Oceanspray	1 Gal.	5%
[Pattern]	<i>Garrya elliptica</i>	Silk Tassel	1 Gal.	10%
[Pattern]	<i>Mahonia aquifolium</i>	Tall Oregon Grape	1 Gal.	5%
[Pattern]	<i>Myrica californica</i>	Pacific Wax Myrtle	1 Gal.	10%
[Pattern]	<i>Philadelphus lewisii</i>	Mockorange	1 Gal.	5%
[Pattern]	<i>Physocarpus capitatus</i>	Pacific Ninebark	1 Gal.	5%
[Pattern]	<i>Ribes malvaecium</i>	Chapparral Currant	1 Gal.	5%
[Pattern]	<i>Rosa gymnocarpa</i>	Baldhip Rose	1 Gal.	5%
[Pattern]	<i>Sambucus racemosa</i>	Red Elderberry	1 Gal.	5%
[Pattern]	<i>Spiraea douglasii</i>	Douglas Spiraea	1 Gal.	5%
[Pattern]	<i>Symphoricarpos albus</i>	Snowberry	1 Gal.	5%
[Pattern]	<i>Vaccinium ovatum</i>	Evergreen Huckleberry	1 Gal.	5%
[Pattern]	<i>Viburnum edule</i>	Highbush cranberry	1 Gal.	5%

Planting Clusters - See sheet 00-LU-410 for layout details

Planting Clusters				
Legend	Botanical Name	Common Name	Plant Size	% Composition
A1	<i>Quercus garryana</i>	Oregon White Oak	1/2" Bareroot	100%
A2	<i>Pinus ponderosa</i> var. <i>benthamiana</i>	Pacific Ponderosa Pine	1/2" Bareroot	20%
	<i>Quercus garryana</i>	Oregon White Oak	1/2" Bareroot	80%
A3	<i>Amelanchier alnifolia</i>	Western Service Berry	1 Gal. Bareroot	5%
	<i>Holodiscus discolor</i>	Oceanspray	1 Gal. Bareroot	5%
	<i>Mahonia aquifolium</i>	Oregon Grape	1 Gal. Bareroot	10%
	<i>Philadelphus lewisii</i>	Mockorange	1 Gal. Bareroot	5%
	<i>Physocarpus capitatus</i>	Ninebark	1 Gal. Bareroot	5%
	<i>Quercus garryana</i>	Oregon Oak	1/2" Bareroot	30%
	<i>Rosa gymnocarpa</i>	Baldhip Rose	1 Gal. Bareroot	15%
	<i>Symphoricarpos albus</i>	Snowberry	1 Gal. Bareroot	15%
B1	<i>Mahonia aquifolium</i>	Oregon Grape	1 Gal. Bareroot	20%
	<i>Rhamnus purshiana</i>	Cascara	1/2" Bareroot	10%
	<i>Salix scouleriana</i>	Scouler's Willow	1/2" Bareroot	5%
	<i>Sambucus cerulea</i>	Blue elderberry	1 Gal. Bareroot	10%
	<i>Symphoricarpos albus</i>	Snowberry	1 Gal. Bareroot	50%
	<i>Symphoricarpos mollis</i>	Creeping Snowberry	1 Gal. Bareroot	5%
C1	<i>Mahonia aquifolium</i>	Tall Oregon Grape	1 Gal. Bareroot	20%
	<i>Rosa gymnocarpa</i>	Baldhip Rose	1 Gal. Bareroot	20%
	<i>Rubus parviflorus</i>	Thimbleberry	1 Gal. Bareroot	50%
	<i>Symphoricarpos albus</i>	Snowberry	1 Gal. Bareroot	10%

Type1 Seeding

Seeded Mowing Area			
Legend	Botanical Name	Common Name	Percentage/PLS
[Pattern]	<i>Fleur de Lawn Blanche</i>		PLS
[Pattern]	<i>Lolium perenne</i>	Perennial Ryegrass	40%
[Pattern]	<i>Festuca trachyphylla</i>	Hard Fescue	22%
[Pattern]	<i>Festuca 'Quatro'</i>	Quatro Tetraploid Sheep Fescue	20%
[Pattern]	<i>Trifolium repens</i>	White Clover	5%
[Pattern]	<i>Achillea millefolium</i>	White Yarrow	5%
[Pattern]	<i>Lobularia maritima</i>	Sweet Alyssum	5%
[Pattern]	<i>Bellis perennis</i>	Single White English Daisy	3%

Type 2 Seeding

Grassland Seeding - Bunchgrass Focused			
Legend	Botanical Name	Common Name	Lbs/Acre
Grasses			
[Pattern]	<i>Danthomia californica</i>	California Oatgrass	6
[Pattern]	<i>Deschampsia elongata</i>	Slender Hairgrass	5
[Pattern]	<i>Festuca occidentalis</i>	Western Fescue	1
[Pattern]	<i>Festuca roemerii</i>	Roemer's Fescue	2
[Pattern]	<i>Hordeum brachyantherum</i>	Meadow Barley	1
[Pattern]	<i>Koeleria macrantha</i>	Prairie Junegrass	1
[Pattern]	<i>Poa scabrella</i>	Pine Junegrass	1
Forbs			
[Pattern]	<i>Achillea millefolium</i>	Yarrow	0.5
[Pattern]	<i>Anaphalis marginata</i>	Pearly Everlasting	0.5
[Pattern]	<i>Epilobium angustifolium</i>	Fireweed	0.5
[Pattern]	<i>Eriophyllum lanatum</i>	Oregon Sunshine	1
[Pattern]	<i>Geranium oregonum</i>	Western Geranium	1
[Pattern]	<i>Lupinus polyphyllus</i>	Bigleaf Lupine	0.1
[Pattern]	<i>Prunella vulgaris</i> ssp. <i>lanceolata</i>	Common Selfheal	1
[Pattern]	<i>Sidalcea campestris</i>	Meadow checkermallow	1
[Pattern]	<i>Lomatium utriculatum</i>	Common biscuitroot	1
[Pattern]	<i>Lomatium macrocarpum</i>	Bigseed Biscuitroot	1
[Pattern]	<i>Solidago canadensis</i>	Canada Goldenrod	0.25

Type 3 Seeding

Grassland Seeding - Color and Fire Resistance Focused			
Legend	Botanical Name	Common Name	Lbs/Acre
[Pattern]	<i>Danthomia californica</i>	California Oatgrass	6
[Pattern]	<i>Deschampsia elongata</i>	Slender Hairgrass	5
[Pattern]	<i>Festuca occidentalis</i>	Western Fescue	1
[Pattern]	<i>Festuca roemerii</i>	Roemer's Fescue	2
[Pattern]	<i>Hordeum brachyantherum</i>	Meadow Barley	2
[Pattern]	<i>Koeleria macrantha</i>	Prairie Junegrass	1
[Pattern]	<i>Poa scabrella</i>	Pine Junegrass	2
Forbs			
[Pattern]	<i>Achillea millefolium</i>	Yarrow	0.5
[Pattern]	<i>Asclepias speciosus</i>	Milkweed	0.5
[Pattern]	<i>Anaphalis marginata</i>	Pearly Everlasting	0.5
[Pattern]	<i>Brodiaea coronaria</i>	Brodiaea	0.5
[Pattern]	<i>Epilobium angustifolium</i>	Fireweed	0.25
[Pattern]	<i>Eriophyllum lanatum</i>	Oregon Sunshine	0.5
[Pattern]	<i>Gaillardia aristata</i>	blanket flower	0.5
[Pattern]	<i>Geranium oregonum</i>	Western Geranium	0.5
[Pattern]	<i>Lomatium macrocarpum</i>	Bigseed Biscuitroot	1
[Pattern]	<i>Lupinus polyphyllus</i>	Bigleaf Lupine	0.1
[Pattern]	<i>Penstemon cardwellii</i>	Cardwell's penstemon	0.25
[Pattern]	<i>Prunella vulgaris</i> ssp. <i>lanceolata</i>	Common Selfheal	0.5
[Pattern]	<i>Sidalcea campestris</i>	Meadow checkermallow	0.5
[Pattern]	<i>Solidago canadensis</i>	Canada Goldenrod	0.5

See Sheet 00-LU-404 for stormwater plants

File: W02229-F00-LU-409.dgn Model: Layout1 ColorTable: user attached from dialog DesignScript: PWB_PenTable.pen PlotScale: 1:0.08333333 Plot Date: 2-DEC-2022 12:04 User: JASON



Designed By	Design Mgr	XXX
Drawn By	Const Mgr	XXX
Checked By	Const Supvr	XXX
Project Mgr	Date	12/30/22

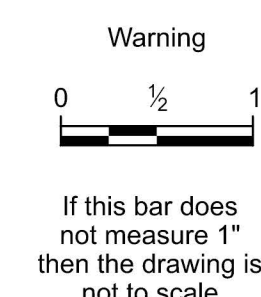

David W. Peters, Engineering Manager, PE No 16683



Bull Run Filtration Facility
Land Use Plans
Plant Species and Sizes

Exhibit A.212.s

SAP Project No	W02229
1/4 Section	-
Sheet No	00-LU-409
	19



Plot Date: 2-DEC-2022 12:17 User: JASON File: W02229-FF-00-LU-410.dgn Model: Layout1 ColorTable: user attached from dialog DesignScript: PWB_PenTable.pen PlotScale: 1:0.08333333

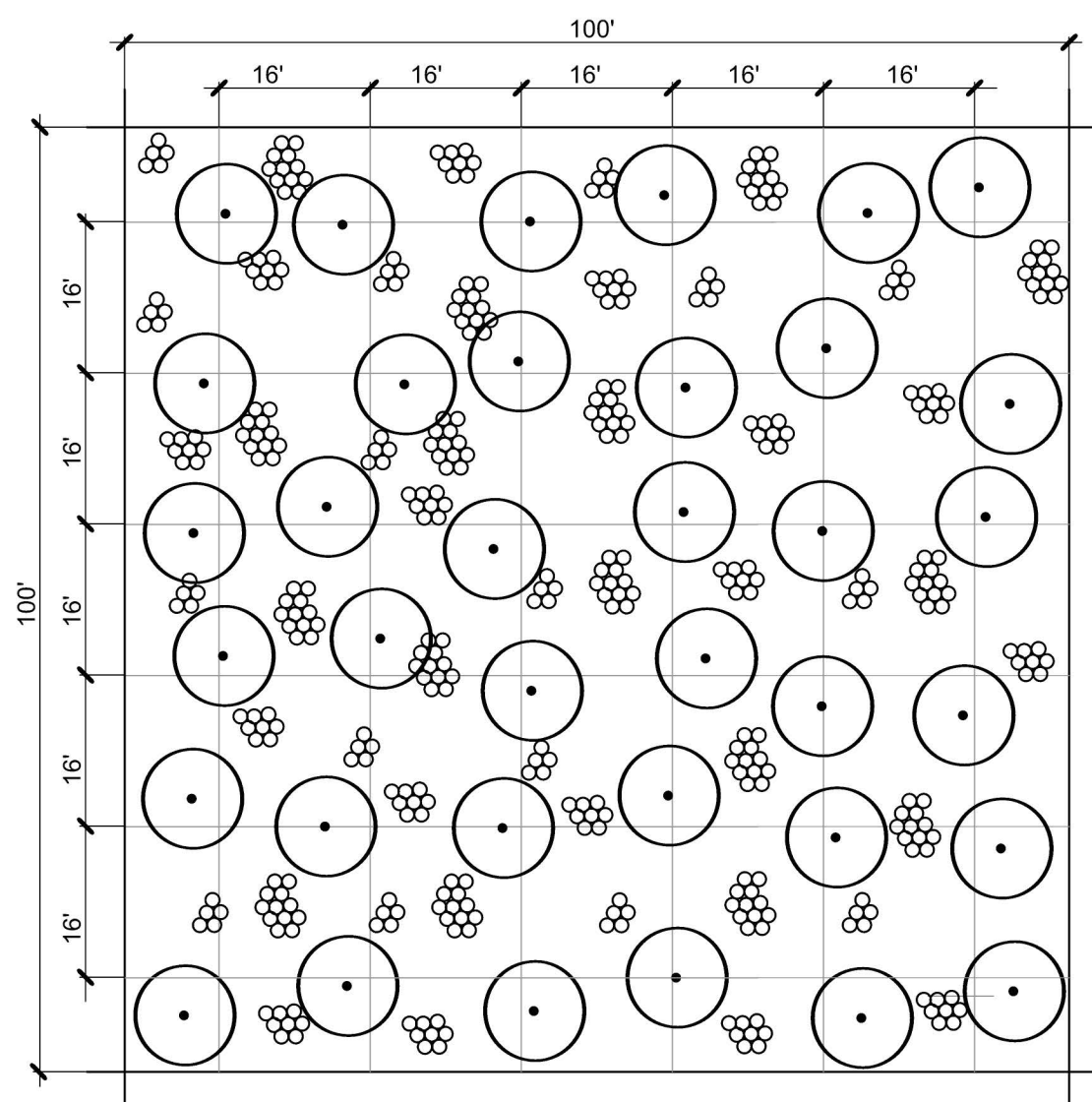

- NOTES**
- 1) Prior to installing plants, apply Grassland Seeding mix and establish for 45-days minimum.
 - 2) Install trees at an overall density of 39 trees/10,000 s.f. (170/acre)
 - 3) Install trees 10'-22' on-center; average 16' on-center.
 - 4) Install shrubs at an overall density of 400 shrubs/10,000 s.f. (11742/acre)
 - 5) Install shrubs in groups of 3-12 plants per species. Space shrubs 1' min to 3' max on-center.
 - 6) provide 5' minimum spacing between shrub groups and between a tree and shrubs group.
 - 7) Spread species throughout the given planting area to avoid monocultures, a random 10,000 s.f. sample should contain all species.
 - 8) Maintain a 1' diameter plant-free area around all stems and mulch with wood chip mulch to prevent weeds.
 - 9) See Planting Mixes on 00-GEN-L101 for planting types and densities.

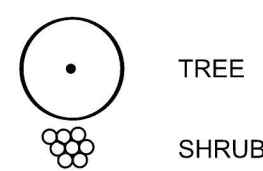

Screening Mix: Forested Planting
NTS

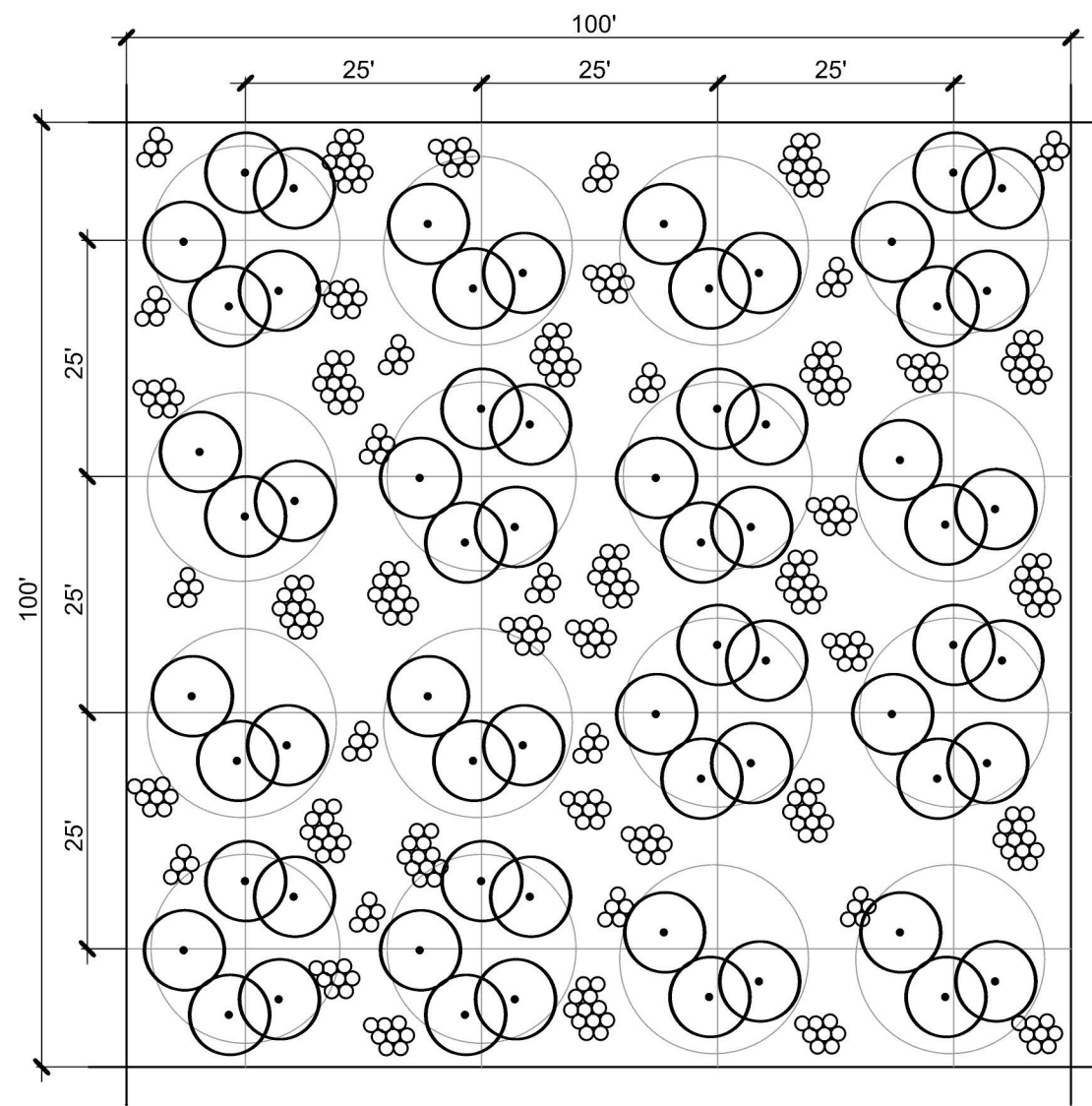

- NOTES**
- 1) Prior to installing plants, apply Grassland Seeding mix and establish for 45-days minimum.
 - 2) Install trees in clumps within a 20' diameter circle spaced 25' on-center. Space trees at least 9' apart minimum.
 - 3) 50% of tree clumps to be 5 trees: 3 conifers and 2 deciduous; 50% of tree clumps to be 3 conifers.
 - 4) Install shrubs at an overall density of 400 shrubs/10,000 s.f. (11742/acre)
 - 5) Install shrubs in groups of 3-12 plants per species. Space shrubs 1' min to 3' max on-center.
 - 6) provide 5' minimum spacing between shrub groups and between a tree and shrubs group.
 - 7) Spread species throughout the given planting area to avoid monocultures, a random 10,000 s.f. sample should contain all species.
 - 8) Maintain a 1' diameter plant-free area around all stems and mulch with wood chip mulch to prevent weeds.
 - 9) See Planting Mixes on 00-GEN-L101 for planting types and densities.

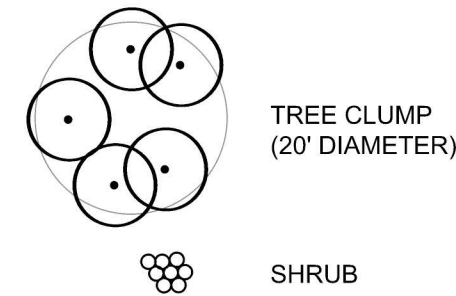

Screening Mix: Shrubby Planting
NTS

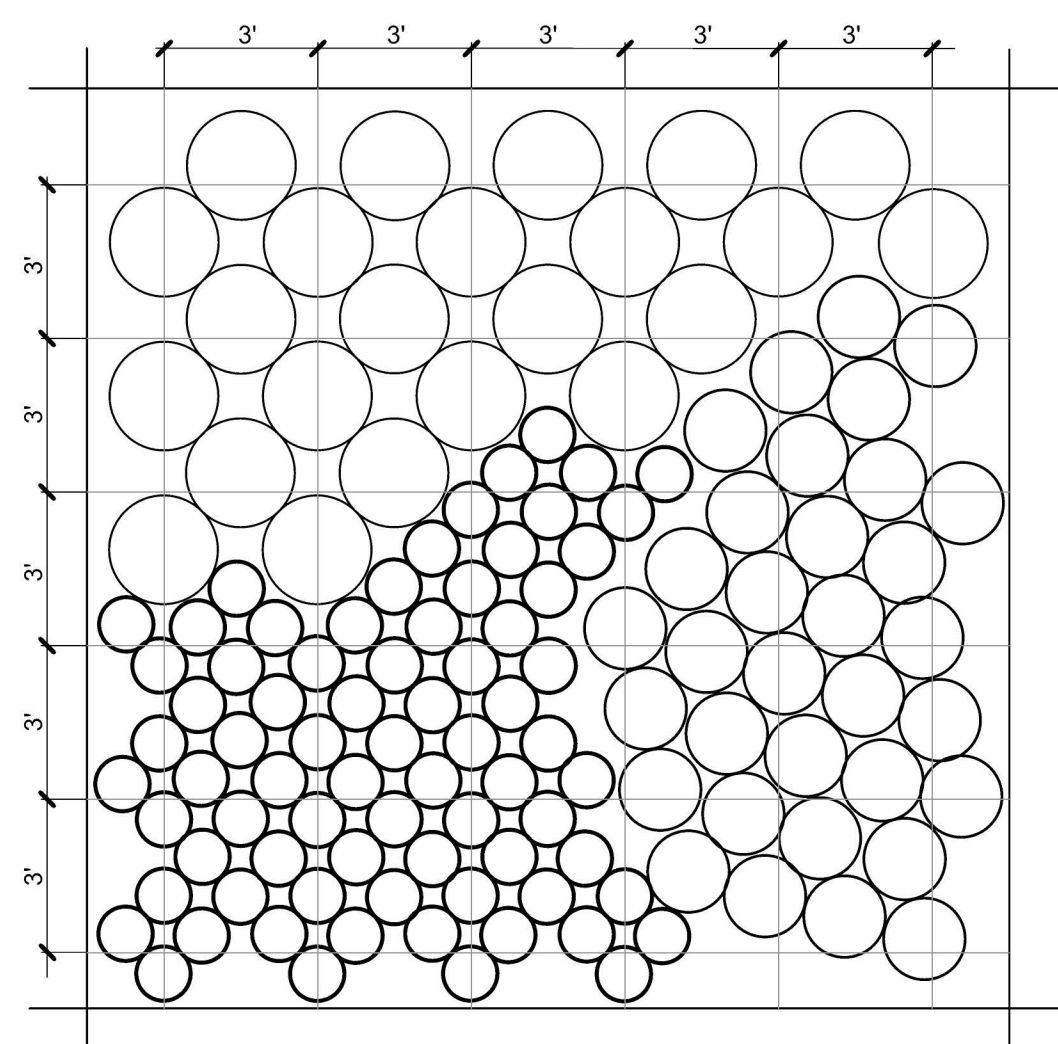

- NOTES**
- 1) Install *Arctostaphylos* 'Vancouver Jade' average 3' on-center, square spacing.
 - 2) Install *Carex flacca* average 1.5' on-center, square spacing.
 - 3) Install *Fragaria chiloensis* average 2' on-center, square spacing.
 - 4) Install groundcover plants in groups of a minimum of 270 and a maximum of 810 of plants per species.
 - 5) Final placement will be approved by Owner's representative prior to planting. Plant groupings should respond to the immediate area's topography and feature shrubs and trees.
 - 6) A single bed area sample should contain all species.
 - 7) Planting groups shall not abut species of the same group.
 - 8) Maintain a 1' diameter plant-free area around all stems and mulch with wood chip mulch to prevent weeds.
 - 9) See Planting Mixes on 00-GEN-L101 for planting types and densities.

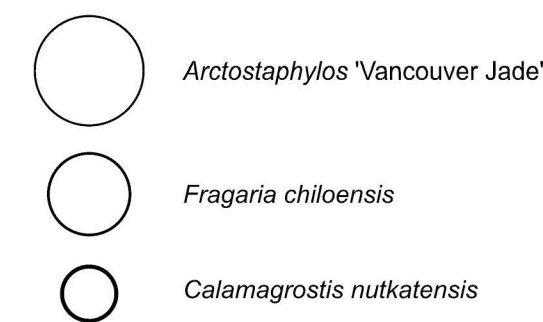

Groundcover Planting
NTS

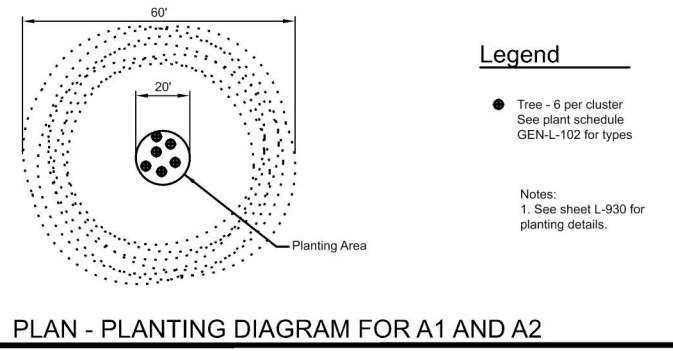

- Legend**
- Tree - 8 per cluster
 - Shrub - 8 per cluster
- Notes:
1. See sheet L-030 for planting details.

PLAN - PLANTING DIAGRAM FOR A1 AND A2

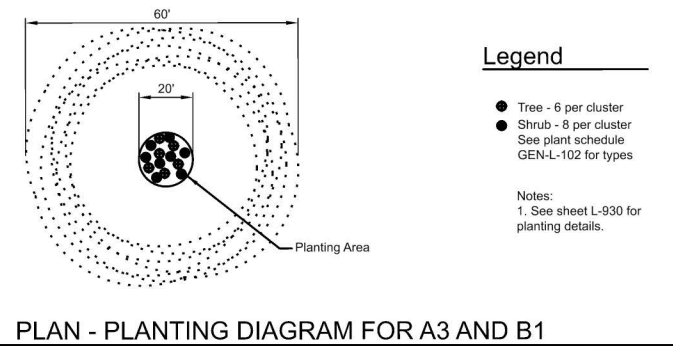

- Legend**
- Tree - 8 per cluster
 - Shrub - 8 per cluster
- Notes:
1. See sheet L-030 for planting details.

PLAN - PLANTING DIAGRAM FOR A3 AND B1

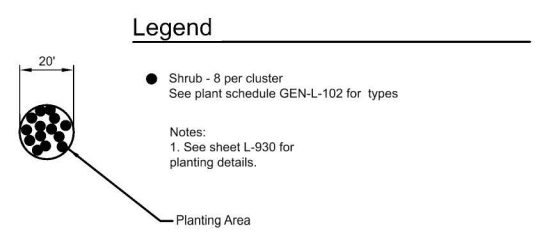

- Legend**
- Shrub - 8 per cluster
- Notes:
1. See sheet L-030 for planting details.

PLAN - PLANTING DIAGRAM FOR C1

Cluster Planting
NTS



No	Date	Description	Appd
1	12/30/22	Building Permit	MIRG
Revision			
Survey			



Designed By	XXX	Design Mgr	XXX
Drawn By	XXX	Const Mgr	XXX
Checked By	XXX	Const Supvr	XXX
Project Mgr	XXX	Date	12/30/22

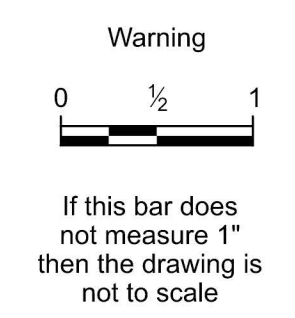

David W. Peters, Engineering Manager, PE No 16683 Date



Bull Run Filtration Facility
Land Use Plans
Planting Details
Exhibit A.212.t

SAP Project No	W02229
1/4 Section	-
Sheet No	00-LU-410
	20

Plot Date: 31-AUG-2022 02:30 User: stanpw11-pw-svc File: W02229_FF_GEN_C_920.dgn Model: GEN-C-920 ColorTable: bw_plt.ctb DesignScript: PWB_PenTable.pen PlotScale: 0.083333:1

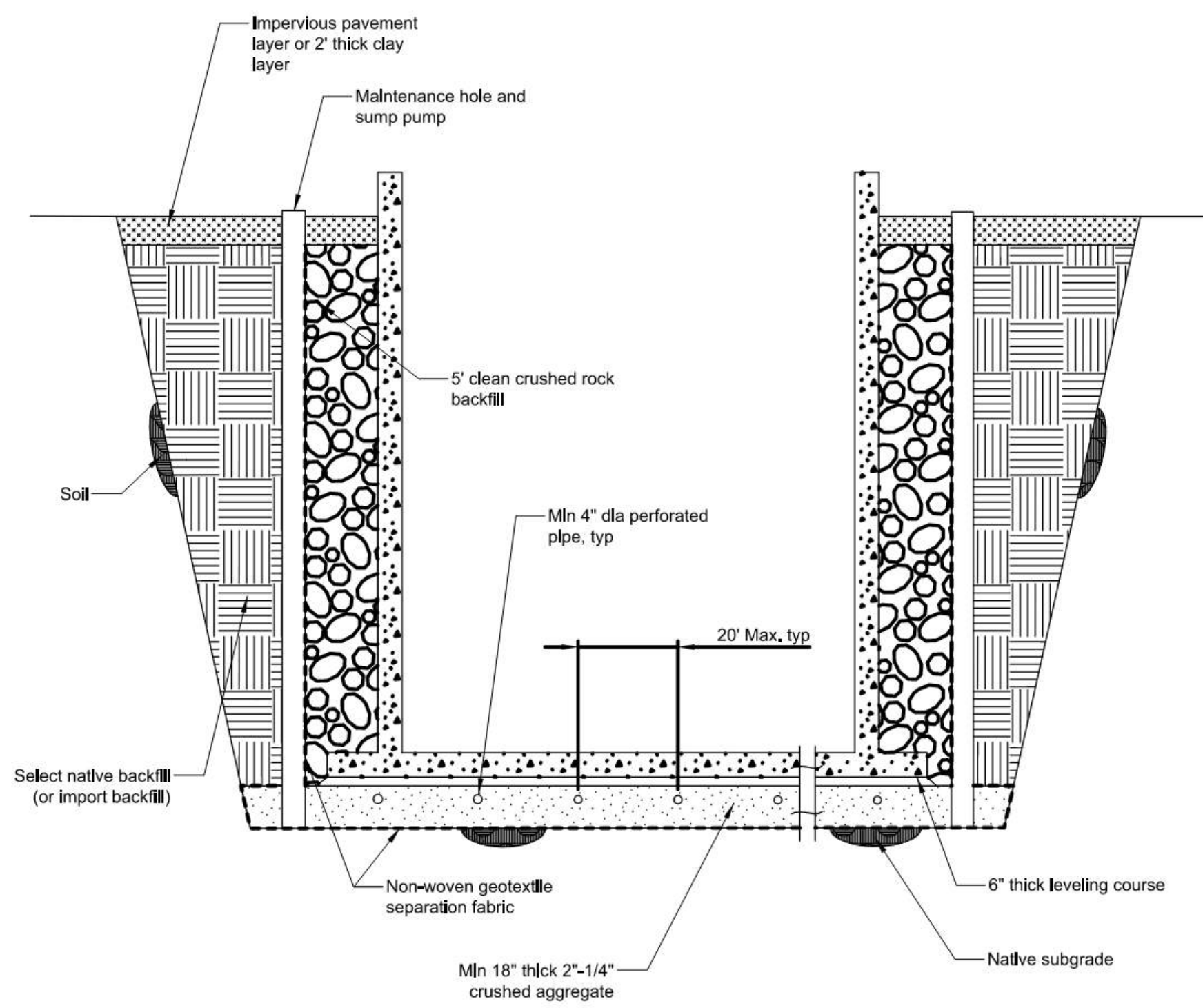

C-160 UNDERDRAIN SYSTEM
NTS

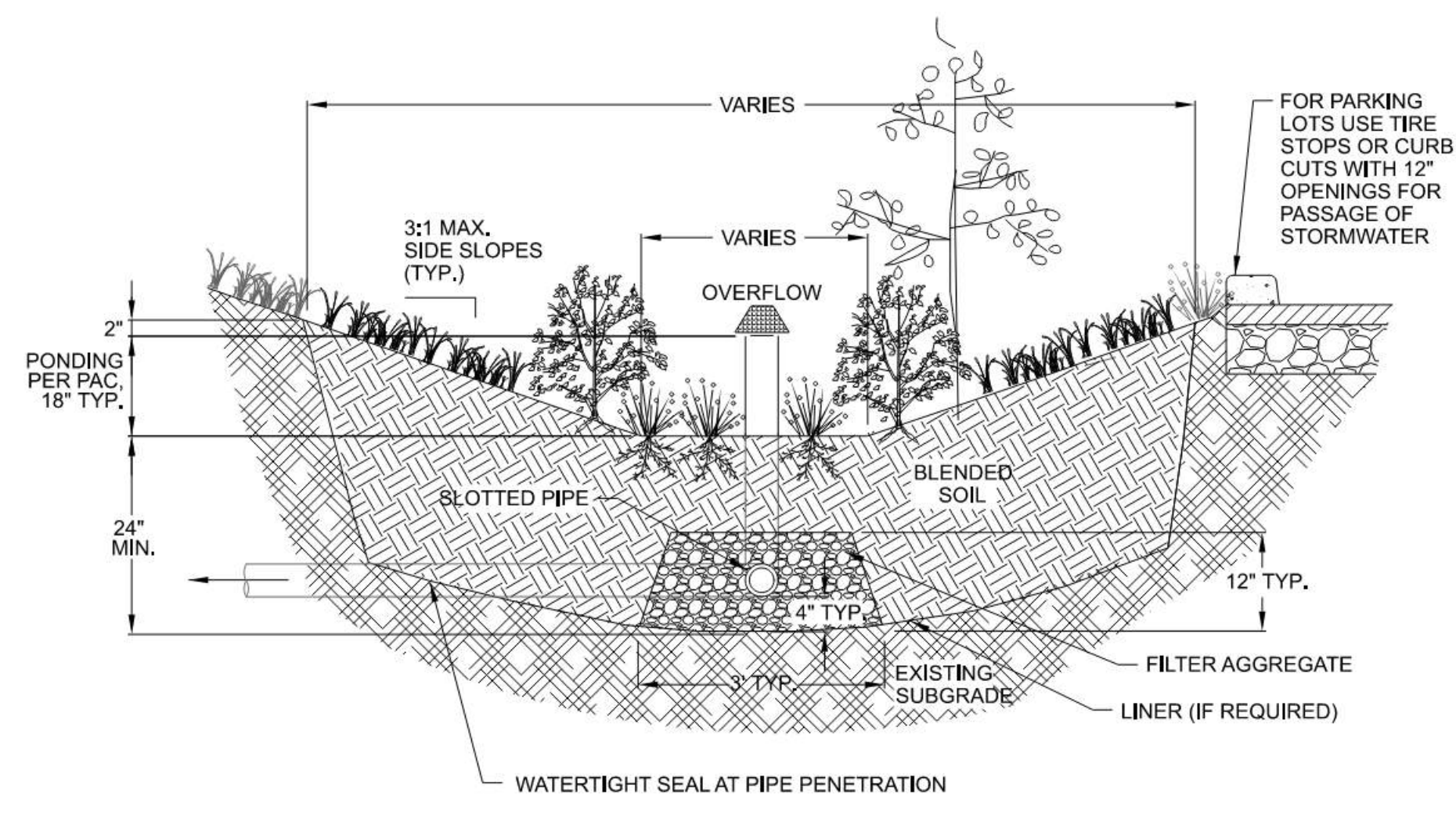

C-161 BASIN WITH UNDERDRAIN
NTS

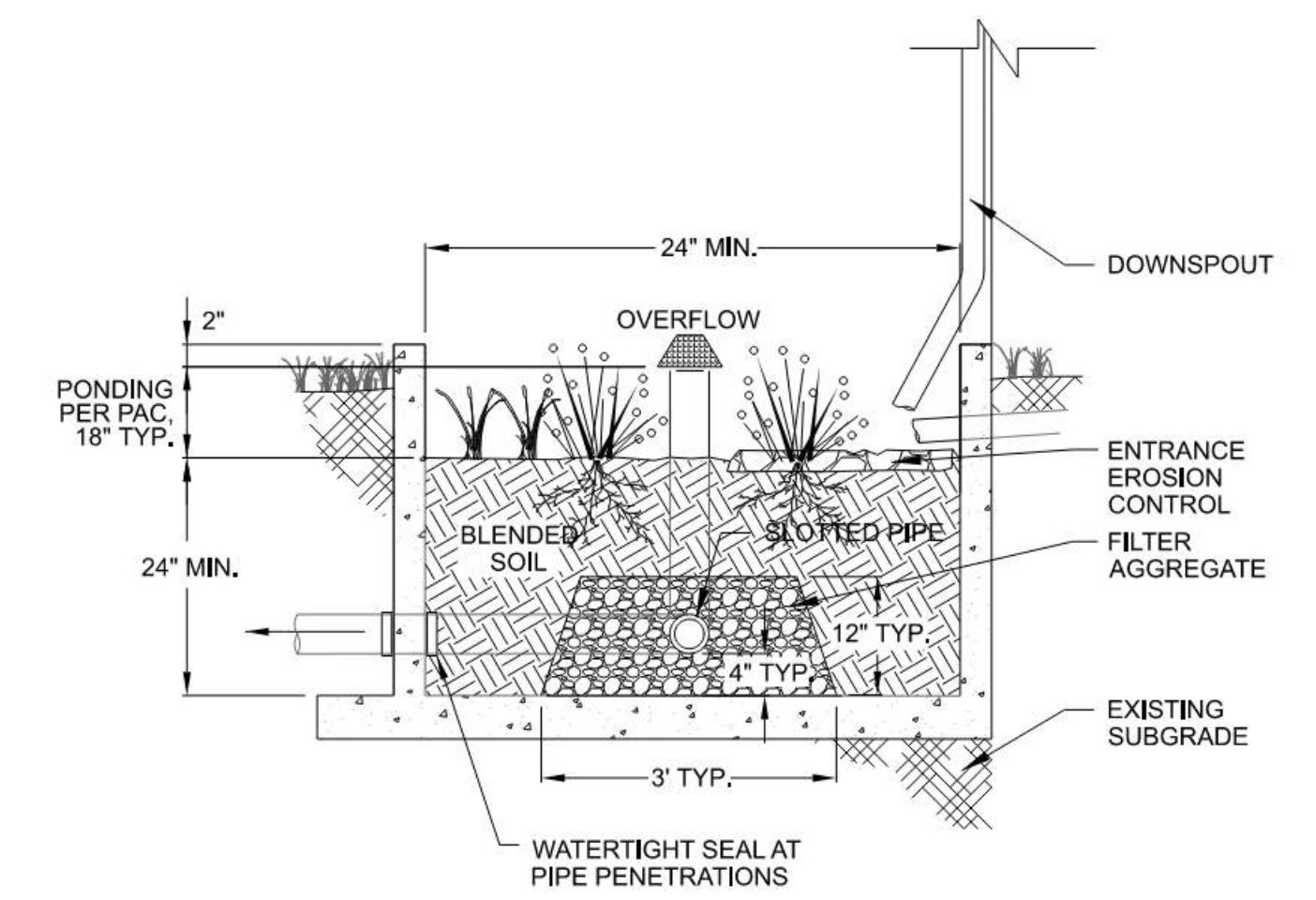

C-162 PLANTER WITH UNDERDRAIN
NTS

No	Date	Description	Appd
C	09/2022	Second Intermediate Design and BCOE Review - 90% Submittal	MRG
B	01/2022	Intermediate Design - 60% Submittal	MRG
A	07/2021	Initial Design - 30% Submittal	MRG

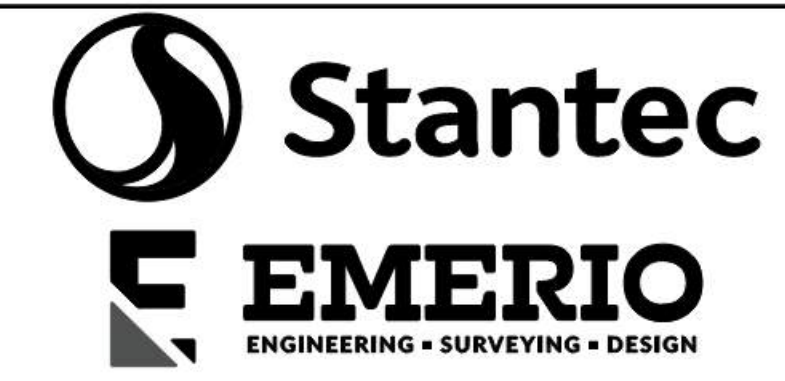

Designed By	RG	Program Mgr	MRG
Drawn By	DJD	Const Mgr	MRG
Checked By	LGS	Const Supvr	MRG
Project Mgr	MRG	Date	09/02/22

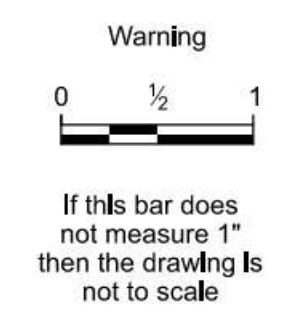

David W. Peters, Engineering Manager, PE No 16683



Bull Run Filtration Facility
Civil
Storm
Details 1
Exhibit A.212.u



PRELIMINARY NOT FOR CONSTRUCTION
Not for permits, pricing or other official purposes. This document has not been completed or checked and is for general information or comment only.

SAP Project No	W02229
1/4 Section	3765 / 3766
Sheet No	GEN-C-920
X of X	X of X

Plot Date: 19-SEP-2022 17:57 User: stanpw11-pw-svc File: W02229_FF_GEN_C_923.dgn Model: GEN-C-923 ColorTable: bw_Plot.ctb DesignScript: PWB_PenTable.pen PlotScale: 0.083333:1

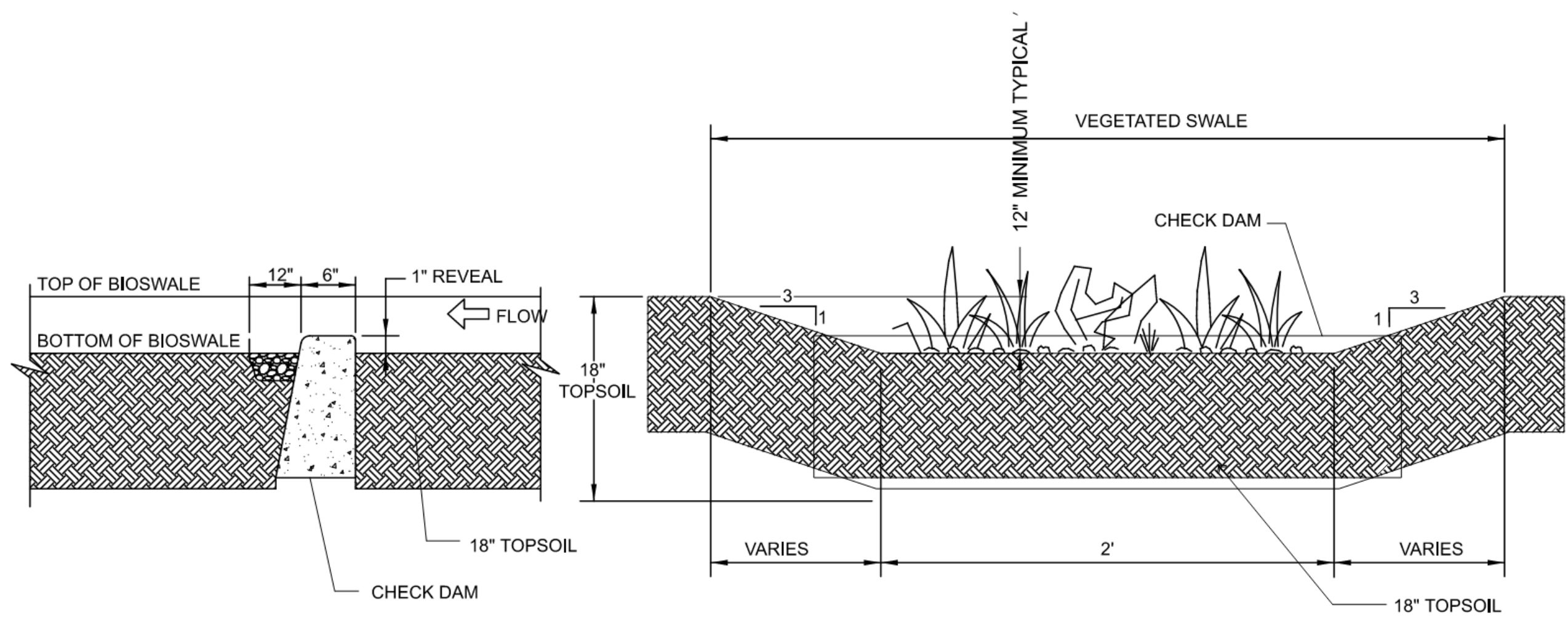

C-168 TYPICAL GRASSY SWALE
NTS

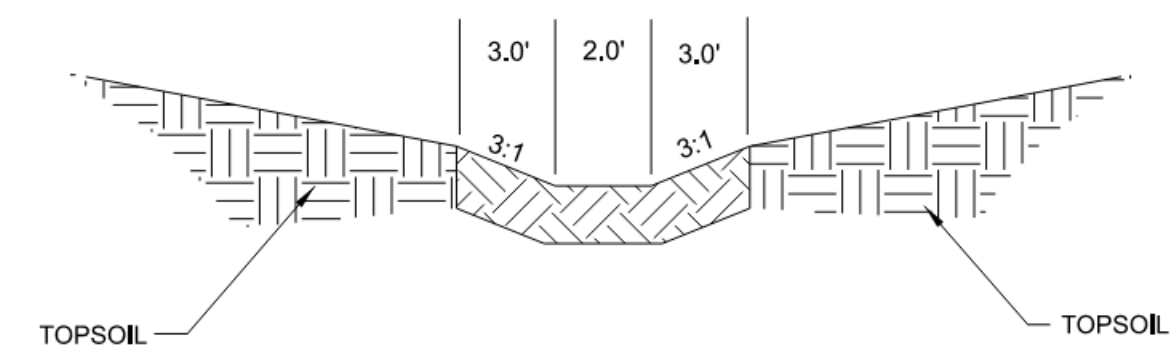

C-169 ROADSIDE DITCH
NTS

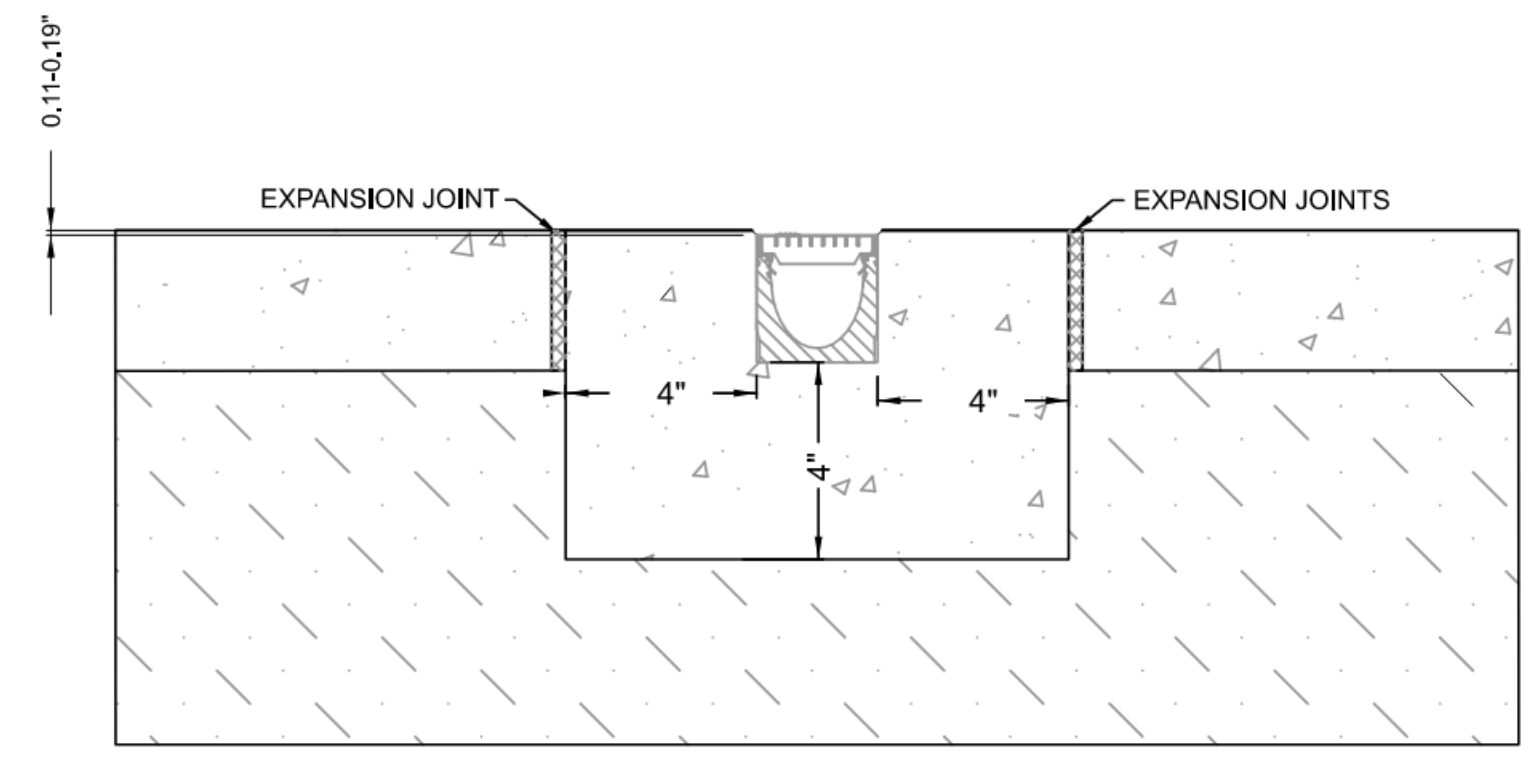

C-170 TRENCH DRAIN
NTS

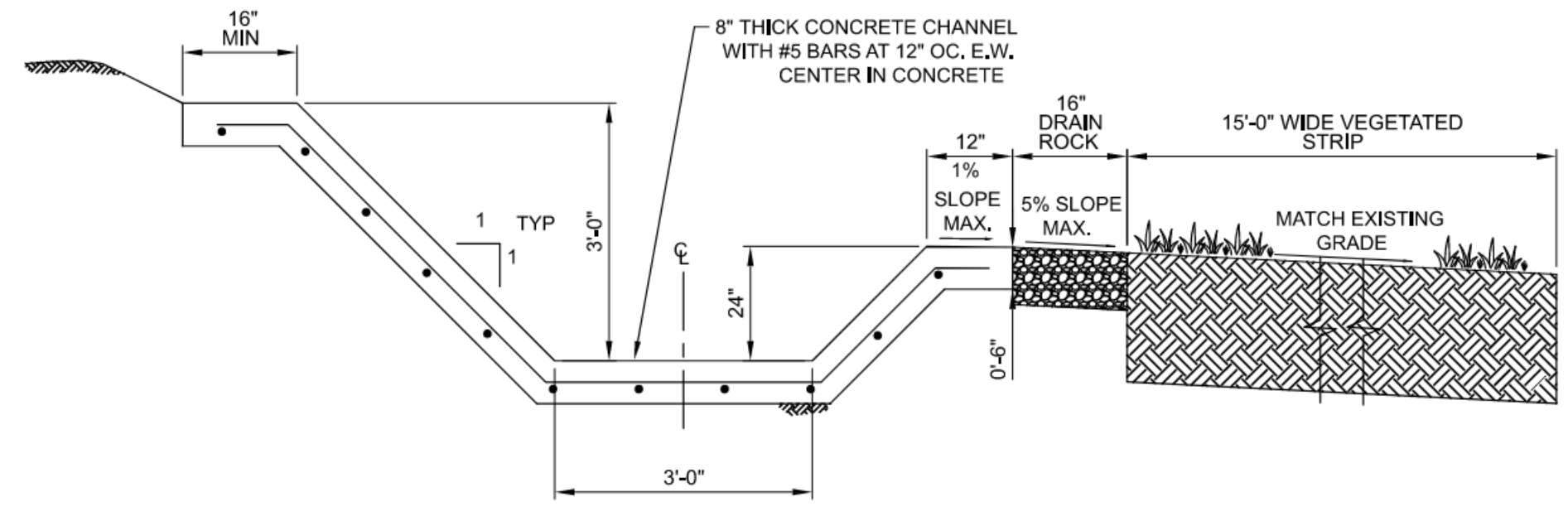

A SECTION VIEW
NTS

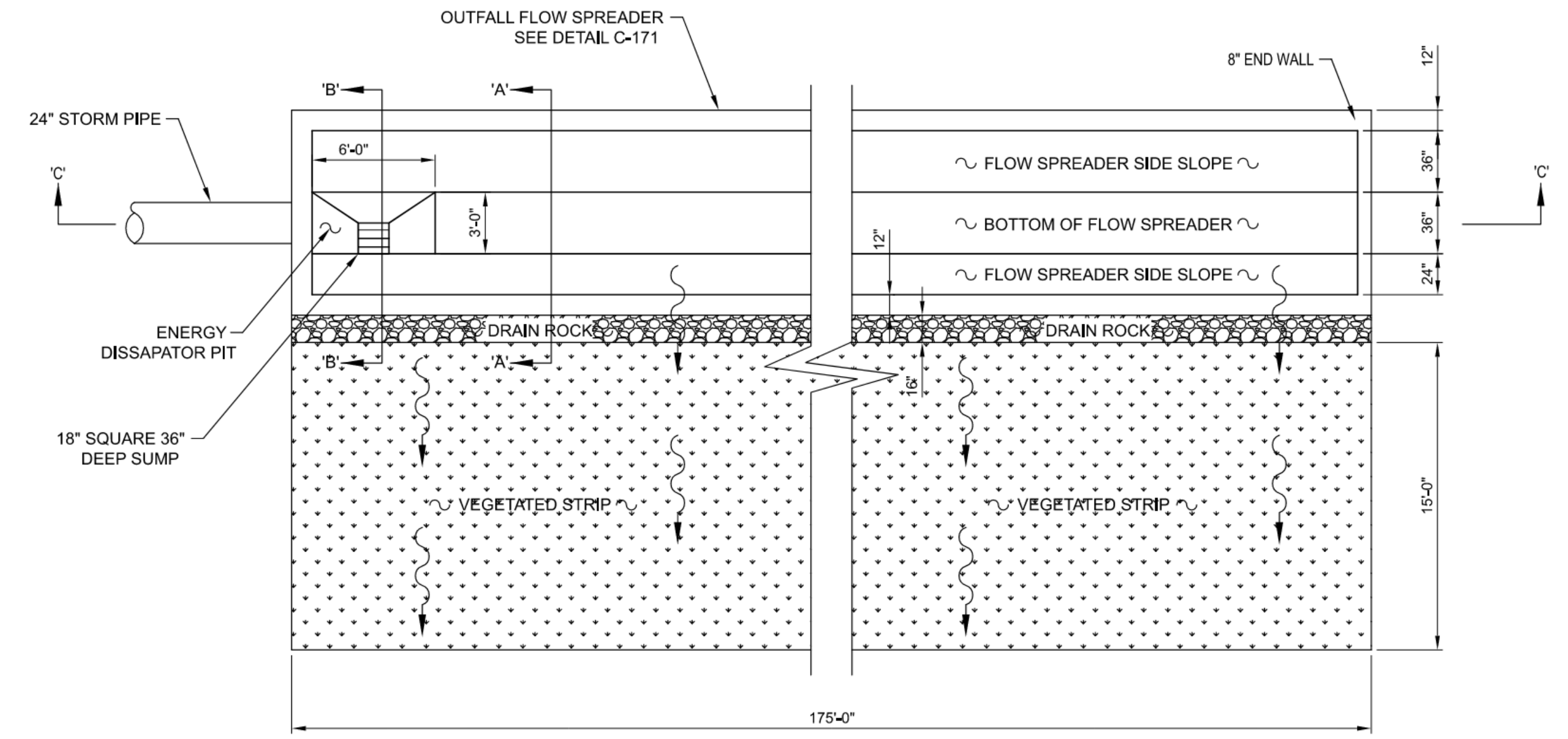

C-171 OUTFALL FLOW SPREADER
NTS

No	Date	Description	Appd
C	09/2022	Second Intermediate Design and BCOE Review - 90% Submittal	MRG
B	01/2022	Intermediate Design - 60% Submittal	MRG
A	07/2021	Initial Design - 30% Submittal	MRG

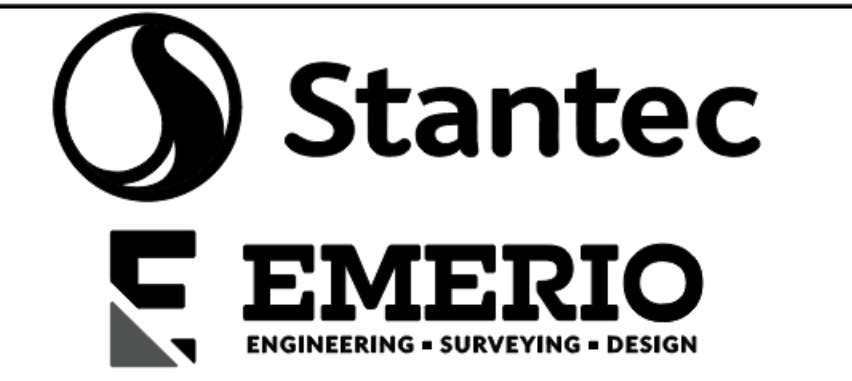

Designed By	RG	Program Mgr	MRK
Drawn By	DJD	Const Mgr	XXX
Checked By	LGS	Const Supvr	MRK
Project Mgr	MRK	Date	09/02/22

Warning
0 1/2 1
If this bar does not measure 1" then the drawing is not to scale



Davd W. Peters, Engineering Manager, PE No 16683



Bull Run Filtration Facility
Civil
Storm
Details 4
Exhibit A.212.v



PRELIMINARY
NOT FOR
CONSTRUCTION
Not for permits, pricing or other official purposes. This document has not been completed or checked and is for general information or comment only.

SAP Project No	W02229
1/4 Section	3765 / 3766
Sheet No	GEN-C-923
X of X	X of X

Attachment B: Lighting Plans

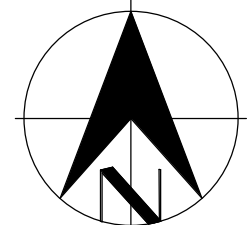

Facility North

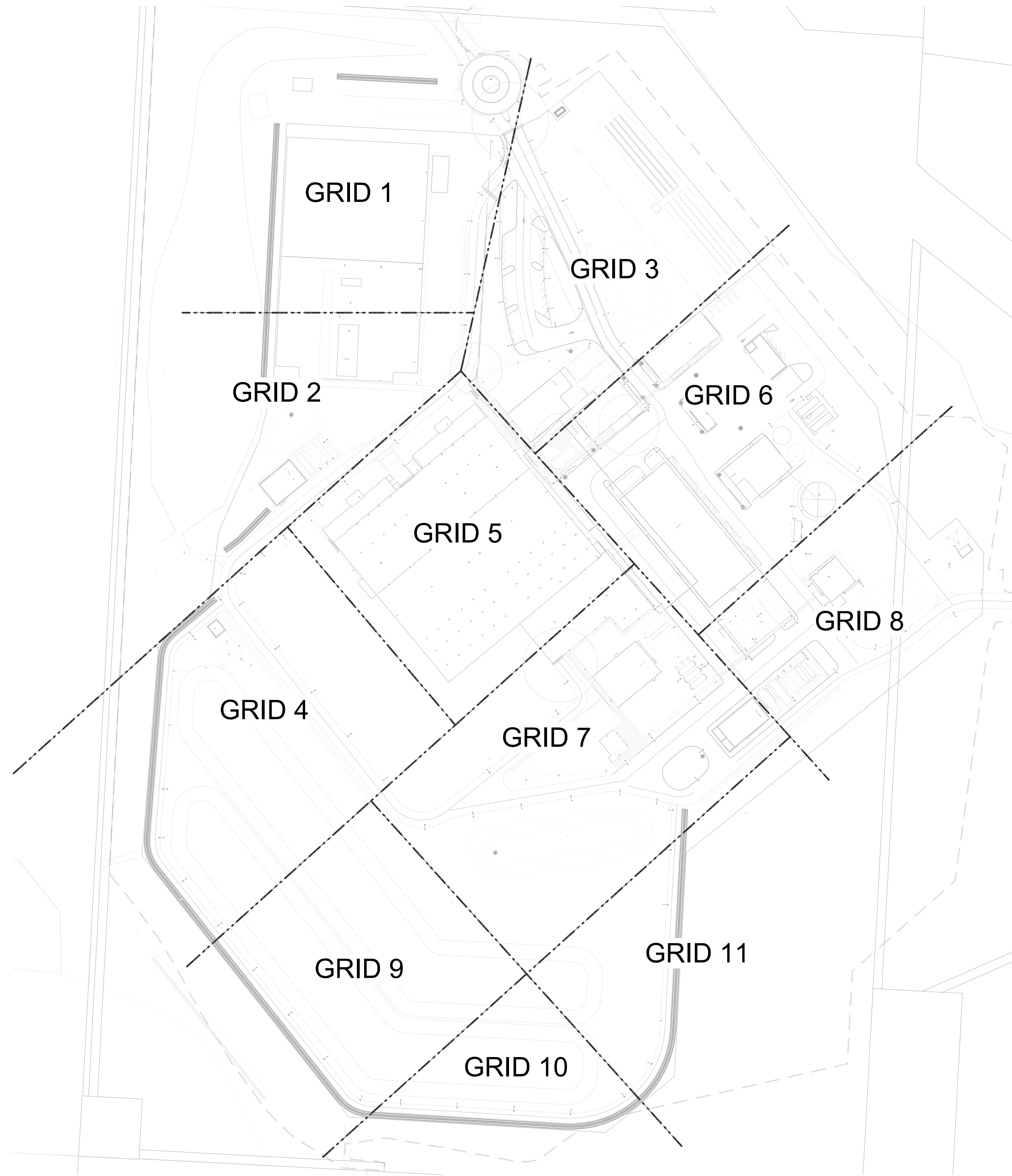

Key Plan

SCALE: 1" = 1560

**PRELIMINARY
NOT FOR
CONSTRUCTION**

Not for permits, pricing or other official purposes. This document has not been completed or checked and is for general information or comment only.

C:\Users\jdfurial\Documents\W02229_FF_03_E_ELCON_jdfurialXJG5G.rvt

9/15/2022 3:03:55 PM

No	Date	Description	Appd
C	09/2022	Second Intermediate Design and BCOE Review - 90% Submittal	MRG
B	01/2022	Intermediate Design - 60% Submittal	MRG
A	07/2021	Initial Design - 30% Submittal	MRG
No			

Revision	
Description	Appd
Survey	



ELCON
ASSOCIATES, INC.

Designed By	Program Mgr
Drawn By	Const Mgr
Checked By	Const Supvr
Project Mgr	Date

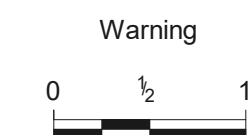

If this bar does not measure 1" then the drawing is not to scale



David W. Peters, Principal Engineer, PE No 16683



Bull Run Filtration Facility

Electrical
Site Lighting
Key Plan

Exhibit A.212.x

SAP Project No
W02229

1/4 Section
3765 / 3766

Sheet No
03-E-322

of

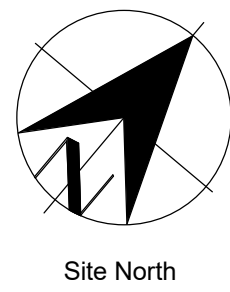

C:\Users\jdfurnia\Documents\W02229_FF_03_E_ELCON_jdfurniaXJG5G.rvt

9/15/2022 3:03:58 PM

No	Date	Description	Appd
C	09/2022	Second Intermediate Design and BCOE Review - 90% Submittal	MRG
B	01/2022	Intermediate Design - 60% Submittal	MRG
A	07/2021	Initial Design - 30% Submittal	MRG
Revision			
Survey		-	



Designed By	Program Mgr
Drawn By	Const Mgr
Checked By	Const Supvr
Project Mgr	Date
MRG	09/02/22

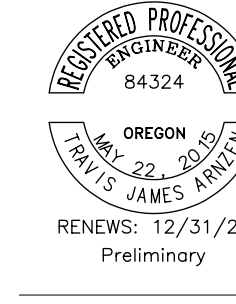
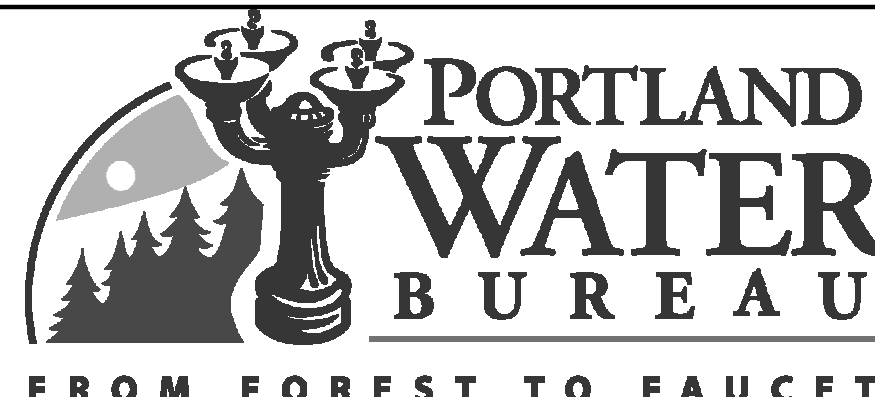
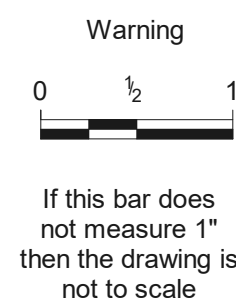

David W. Peters, Principal Engineer, PE No 16683



Date

Bull Run Filtration Facility
Electrical
 Site Lighting
 Lighting & Receptacle Plan
 Grid 1 [Exhibit A.212.y](#)

**PRELIMINARY
NOT FOR
CONSTRUCTION**

Not for permits, pricing or other official purposes. This document has not been completed or checked and is for general information or comment only.

SAP Project No	W02229
1/4 Section	3765 / 3766
Sheet No	03-E-323
of	

General Sheet Notes

- 480V roadway lightpoles with the road name tag shown on this sheet are powered from the building 16 panel, FF16-DP-1001.
- 480V pedestrian and roadway lightpoles with the area name tag are powered from the building feeding the area unless otherwise noted.
- Light pole fixture with the emergency symbol is circuited to 120V emergency panel in the building feeding power to that area. Refer to area specific plans for circuiting and fixture type.
- See sheet GEN-E-142 for Lighting Controls and Controlled Receptacles Schedule and 03-E-334 for Lighting Control Plan.
- See sheets GEN-E-140 and GEN-E-141 for Luminaire Schedule.

Sheet Keynotes

- Plant entry sign floodlights. Provide and install on 8 feet round pole elevated on a 1.5' planting bed. Circuit fixture to FF16-PNL-1001.
- See Area 40 Plans for pole, light fixture, and circuiting information.



Lighting & Receptacle Plan - Grid 1
 SCALE: 1" = 30'-0"



Matchline - See 03-E-323

43 Backwash Pump Station

ZPFA L4308 2,4

ZPWA L4401 1,3

ZR3A-6 LF06 2,4

ZPWA L4301 1,3

ZPWA L4309 1,3

ZPFB L4302 1,3

16 North Electrical Complex

Road F

ZRWB-6 L1601 2,4

ZPFB L1603 1,3

ZPFB 1,3

L1604 ZPFB 1,3

L1605 ZPFB 1,3

ZPFB 1,3

ZPWA LF16 2,4

ZPWA LF17 2,4

Matchline - See 03-E-326

Matchline - See 03-E-327

Matchline - See 03-E-325

General Sheet Notes

- 480V roadway lightpoles with the road name tag shown on this sheet are powered from building 16, FF16-DP-1001.
- 480V pedestrian and roadway lightpoles with the area name tag are powered from the building feeding the area unless otherwise noted.
- Light pole fixture with the emergency symbol is circuited to 120V emergency panel in the building feeding power to that area. Refer to area specific plans for circuiting and fixture type.
- See sheet GEN-E-142 for Lighting Controls and Controlled Receptacles Schedule and 03-E-335 for Lighting Control Plan.
- See sheets GEN-E-140 and GEN-E-141 for Luminaire Schedule.

Sheet Keynotes

- See Area 40 Plans for pole, light fixture, and circuiting information.
- Fixtures are circuited to the panel in building 16.
- Provide and install light pole with fixtures under Bid Alternate except as noted. See specification section 01_23_00 Alternates.

Lighting & Receptacle Plan - Grid 2

SCALE: 1" = 30'-0"

**PRELIMINARY
NOT FOR
CONSTRUCTION**

Not for permits, pricing or other official purposes. This document has not been completed or checked and is for general information or comment only.

C:\Users\jdfurnia\Documents\W02229_FF_03_E_ELCON_jdfurniaXJG5G.rvt

9/15/2022 3:19:58 PM

No	Date	Description	Appd
C	09/2022	Second Intermediate Design and BCOE Review - 90% Submittal	MRG
B	01/2022	Intermediate Design - 60% Submittal	MRG
A	07/2021	Initial Design - 30% Submittal	MRG
No			

Revision	
Description	Appd
Survey	



Designed By	MOCK	Program Mgr	DWIP
Drawn By	AMH	Const Mgr	TG
Checked By	TJA	Const Supvr	RW
Project Mgr	MRG	Date	09/02/22

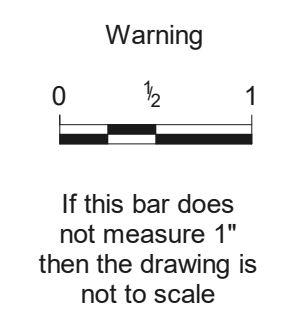

David W. Peters, Principal Engineer, PE No 16683



Bull Run Filtration Facility

Electrical

Site Lighting
Lighting & Receptacle Plan
Grid 2 [Exhibit A.212.z](#)

SAP Project No	W02229
1/4 Section	3765 / 3766
Sheet No	03-E-324
of	

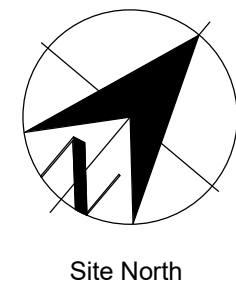

Site North

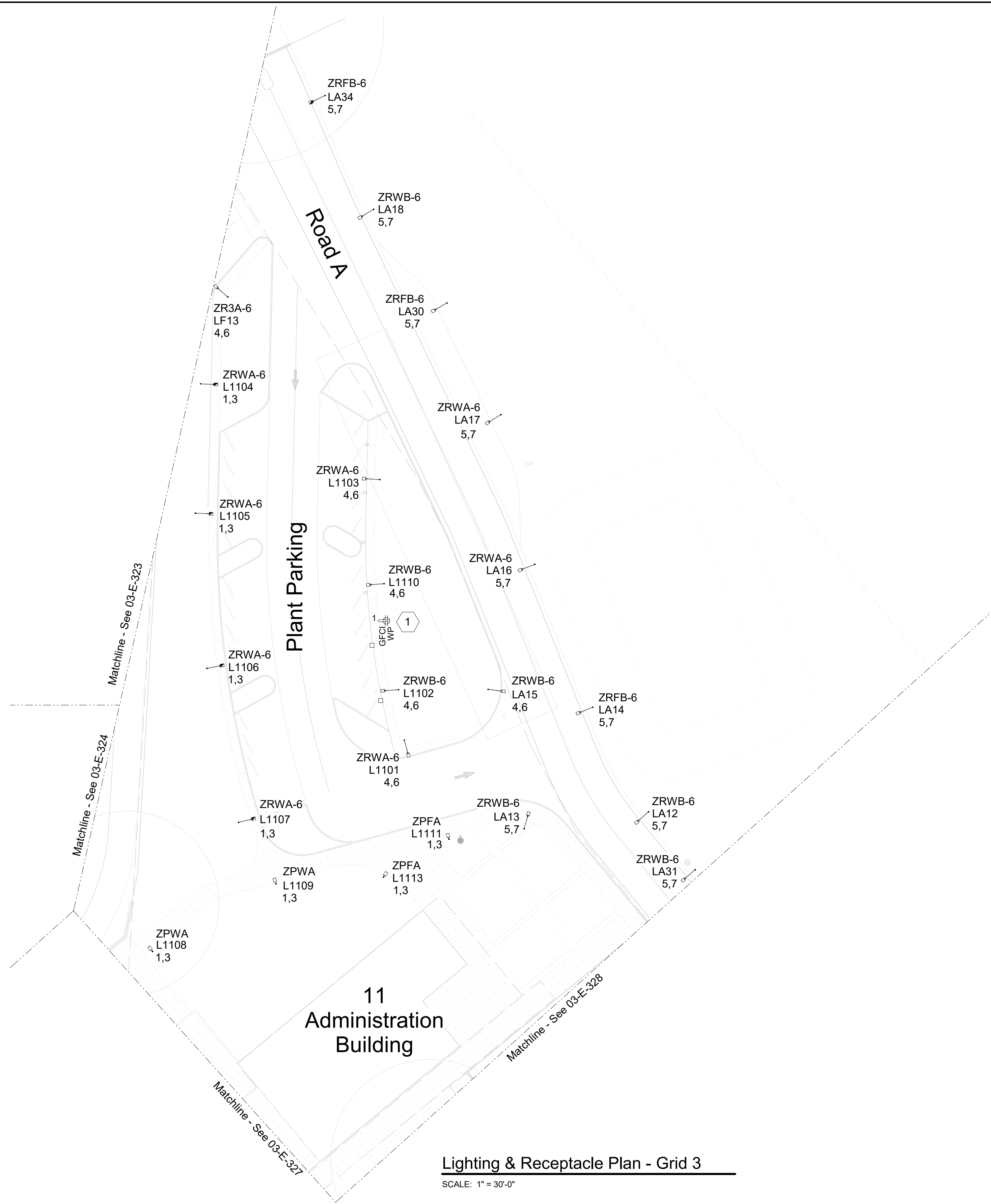

Lighting & Receptacle Plan - Grid 3

SCALE: 1" = 30'-0"

General Sheet Notes

1. All the light poles shown on this sheet are powered from building 11. Refer to area specific plans for the panel name and schedule.
2. Light pole fixture with the emergency symbol is circuited to 120V emergency panel in the building 11.
3. See sheet GEN-E-142 for Lighting Controls and Controlled Receptacles Schedule and 03-E-336 for Lighting Control Plan.
4. See sheets GEN-E-140 and GEN-E-141 for Luminaire Schedule.

Sheet Keynotes

1. Provide and install receptacle.

**PRELIMINARY
NOT FOR
CONSTRUCTION**

Not for permits, pricing or other official purposes. This document has not been completed or checked and is for general information or comment only.

C:\Users\jdfurnia\Documents\W02229_FF_03_E_ELCON_jdfurniaXJG5G.rvt

9/15/2022 3:04:05 PM

No	Date	Description	Appd
C	09/2022	Second Intermediate Design and BCOE Review - 90% Submittal	MRG
B	01/2022	Intermediate Design - 60% Submittal	MRG
A	07/2021	Initial Design - 30% Submittal	MRG
No			



Designed By	Program Mgr
Drawn By	Const Mgr
Checked By	Const Supvr
Project Mgr	Date
MRG	09/02/22

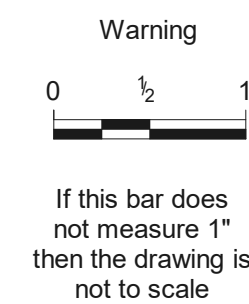

David W. Peters, Principal Engineer, PE No 16683



Date

Bull Run Filtration Facility

Electrical
Site Lighting
Lighting & Receptacle Plan
Grid 3 [Exhibit A.212.aa](#)

SAP Project No
W02229

1/4 Section

3765 / 3766

Sheet No
03-E-325

of

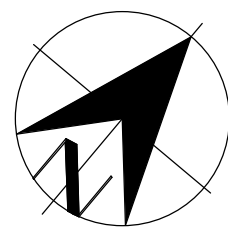

Site North

General Sheet Notes

- 480V roadway lightpoles with the road name tag shown on this sheet are powered from building 15 and 16.
- 480V pedestrian and roadway lightpoles with the area name tag are powered from the building feeding the area unless otherwise noted.
- See sheet GEN-E-142 for Lighting Controls and Controlled Receptacles Schedule and 03-E-337 for Lighting Control Plan.
- See sheets GEN-E-140 and GEN-E-141 for Luminaire Schedule.

Sheet Keynotes

- The fixture is circuited to the panel in building 15.
- The fixture is circuited to the panel in building 16.

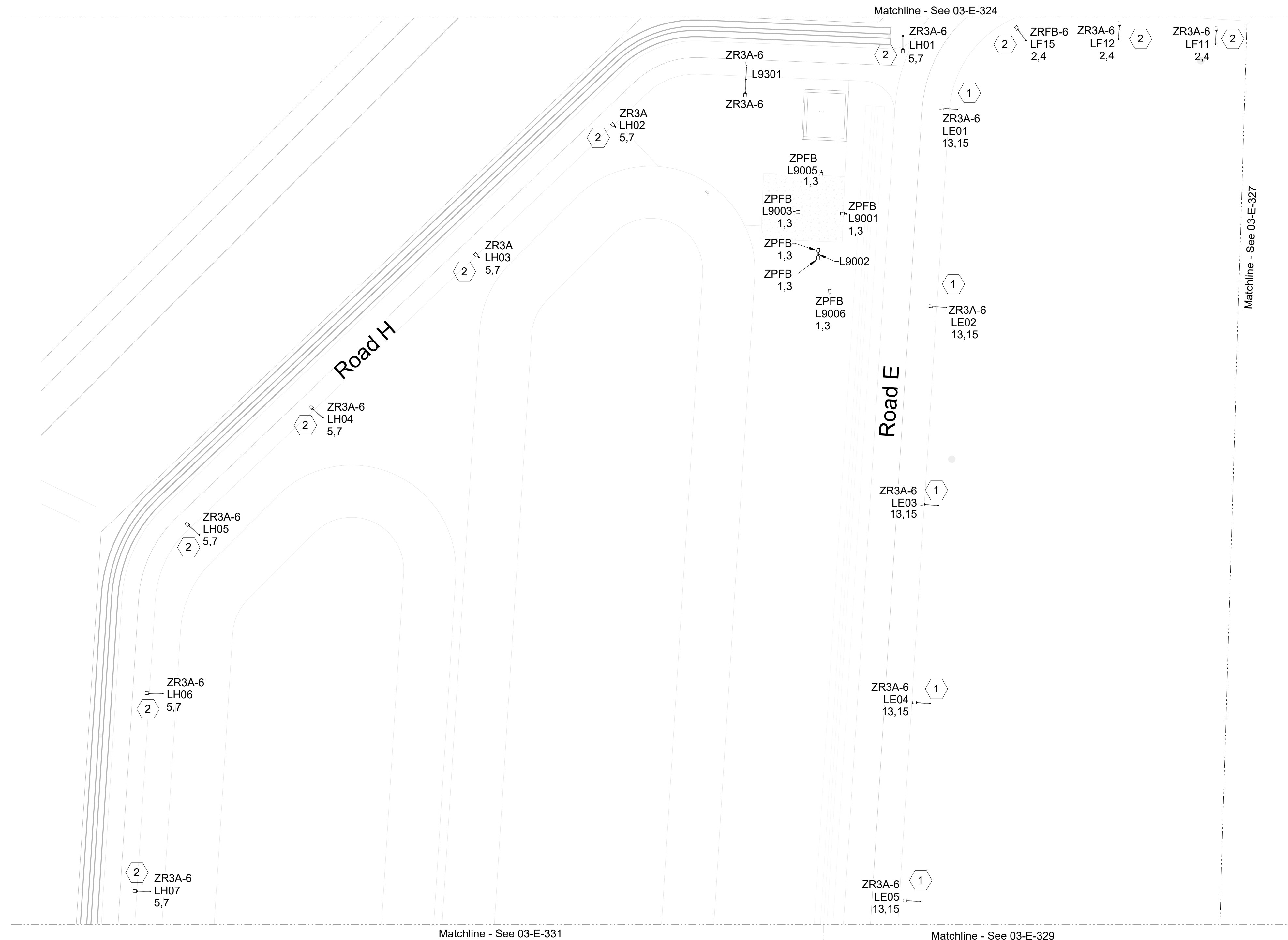

Lighting & Receptacle Plan - Grid 4

SCALE: 1" = 30'-0"

**PRELIMINARY
NOT FOR
CONSTRUCTION**

Not for permits, pricing or other official purposes. This document has not been completed or checked and is for general information or comment only.

C:\Users\jdfurina\Documents\W02229_FF_03_E_ELCON_jdfurinaXJG5G.rvt

9/15/2022 3:04:08 PM

No	Date	Description	Appd
C	09/2022	Second Intermediate Design and BCOE Review - 90% Submittal	MRG
B	01/2022	Intermediate Design - 60% Submittal	MRG
A	07/2021	Initial Design - 30% Submittal	MRG
Revision			
Survey			



Designed By	Program Mgr	MCK	DWP
Drawn By	Const Mgr	AMH	TC
Checked By	Const Supvr	TJA	RW
Project Mgr	Date	MRG	09/02/22

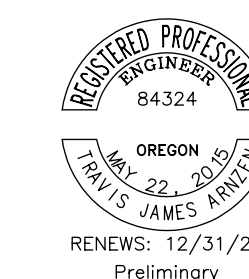
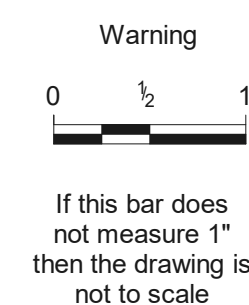

David W. Peters, Principal Engineer, PE No 16683



Bull Run Filtration Facility
Electrical
 Site Lighting
 Lighting & Receptacle Plan
 Grid 4 [Exhibit A.212.bb](#)

SAP Project No	W02229
1/4 Section	3765 / 3766
Sheet No	03-E-326
of	

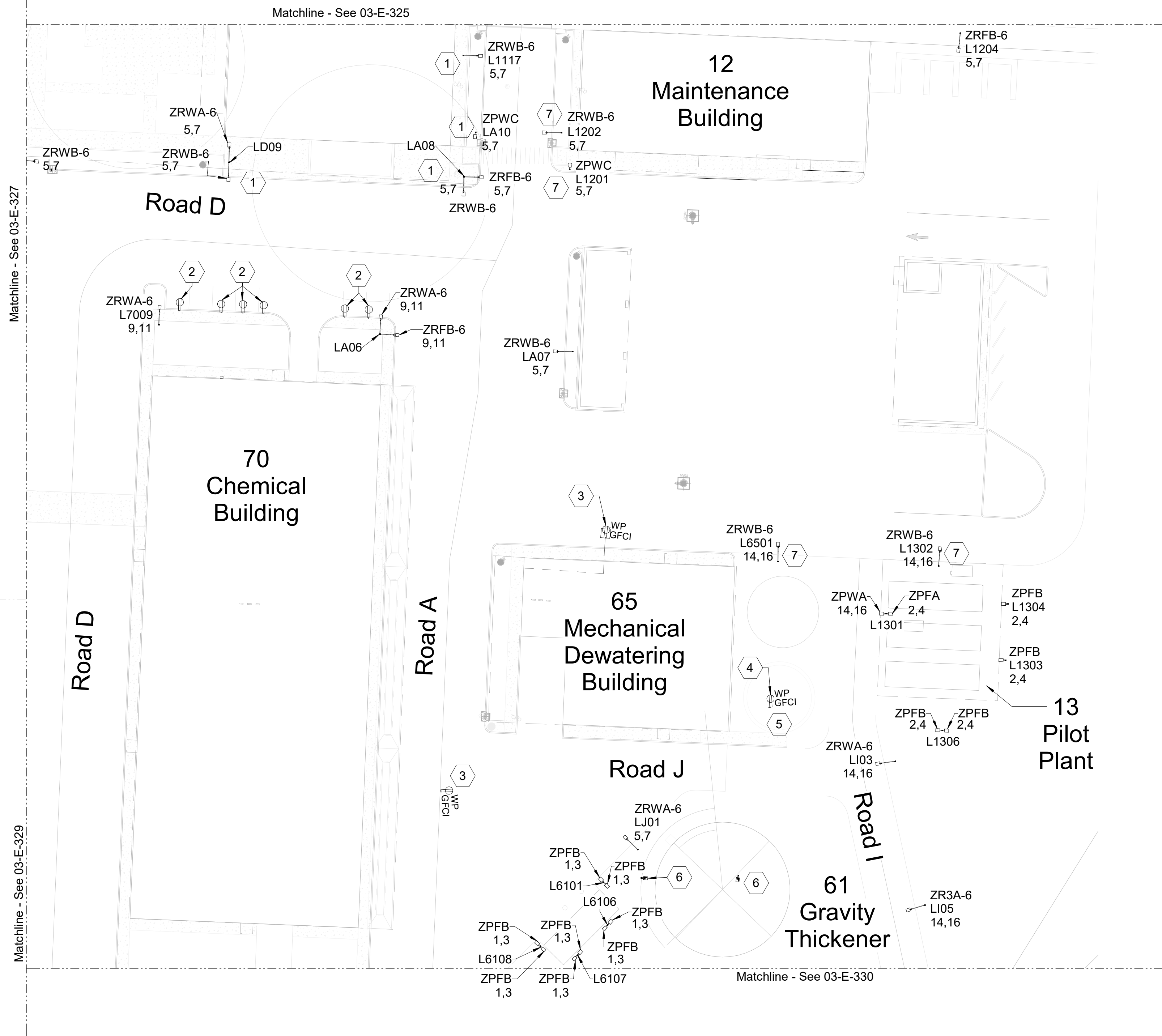
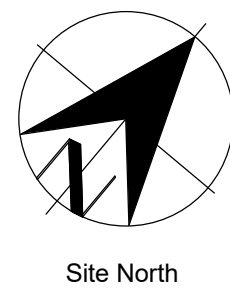

General Sheet Notes

- 480V roadway lightpoles with the road name tag shown on this sheet are powered from the building 15 panel.
- 480V pedestrian and roadway lightpoles with the area name tag are powered from the building feeding the area unless otherwise noted.
- Light pole fixture with the emergency symbol is circuited to 120V emergency panel in the building feeding power to that area. Refer to area specific plans for circuiting.
- See sheet GEN-E-142 for Lighting Controls and Controlled Receptacles Schedule and 03-E-339 for Lighting Control Plan.
- See sheets GEN-E-140 and GEN-E-141 for Luminaire Schedule.
- Task light pole fixtures in area 13, 61 and 51 are circuited to area 65 panel.

Sheet Keynotes

- This fixture is within LEED boundary. It is circuited to the panel in building 11.
- Provide and install dedicated receptacles for cart charger. Refer to area specific plans for circuiting.
- Provide and install a receptacle in the metering vault. Provide with weatherproof and gfcı features. Refer to area specific plans for circuiting.
- Provide and install the dedicated receptacle for 65 tank dewatering pump. See area 65 plans for circuiting.
- See Area 65 plans for lighting and circuiting information on 65 tank dewatering pump.
- See Area 61 plans for pole, light fixture, and circuiting information.
- The light pole is circuited to area 15 panel, FF15-DP-1001.

Lighting & Receptacle Plan - Grid 6

SCALE: 1" = 30'-0"

**PRELIMINARY
NOT FOR
CONSTRUCTION**

Not for permits, pricing or other official purposes. This document has not been completed or checked and is for general information or comment only.

C:\Users\jdfurnia\Documents\W02229_FF_03_E_ELCON_idifurniaXJG5G.rvt

9/15/2022 3:04:15 PM

No	Date	Description	Appd
C	09/2022	Second Intermediate Design and BCOE Review - 90% Submittal	MRG
B	01/2022	Intermediate Design - 60% Submittal	MRG
A	07/2021	Initial Design - 30% Submittal	MRG
No			

Revision	
Description	Appd
Survey	



Designed By	Program Mgr	MOCK	DWIP
Drawn By	Const Mgr	AMH	TC
Checked By	Const Supvr	TJA	RM
Project Mgr	Date	MRG	09/02/22

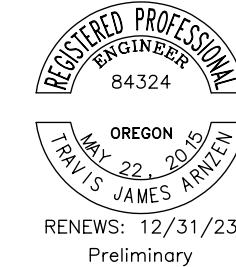
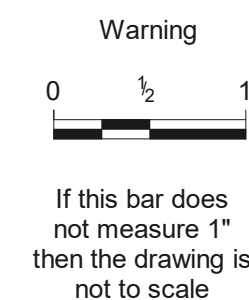

David W. Peters, Principal Engineer, PE No 16683

Date



Bull Run Filtration Facility
Electrical
Site Lighting
Lighting & Receptacle Plan
Grid 6 [Exhibit A.212.dd](#)

SAP Project No	W02229
1/4 Section	3765 / 3766
Sheet No	03-E-328
of	

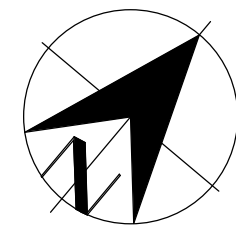

Site North

General Sheet Notes

- 480V roadway lightpoles with the road name tag shown on this sheet are powered from the building 15 panel.
- Area 20 fixtures are powered from the panels in building 31.
- 480V pedestrian and roadway lightpoles with the area name tag are powered from the building feeding the area unless otherwise noted.
- Light pole fixture with the emergency symbol is circuited to 120V emergency panel in the building feeding power to that area. Refer to area specific plans for circuiting.
- See sheet GEN-E-142 for Lighting Controls and Controlled Receptacles Schedule and 03-E-340 for Lighting Control Plan.
- See sheets GEN-E-140 and GEN-E-141 for Luminaire Schedule.

Sheet Keynotes

- Work in this area to be performed under Bid Alternate except as noted. See specification section 01_23_00 Alternates.
- See Area 20 plan for pole, light fixture, and circuit information.
- Fixture is circuited to the emergency panel in building 31; FF31-ELP-1001, CKT # 22.
- Fixture is circuited to the panel in building 81.
- See Area 31 plans for fixture, pole, circuiting information.
- The pole fixture is circuited to area 31 panel, FF31-DP-1001.

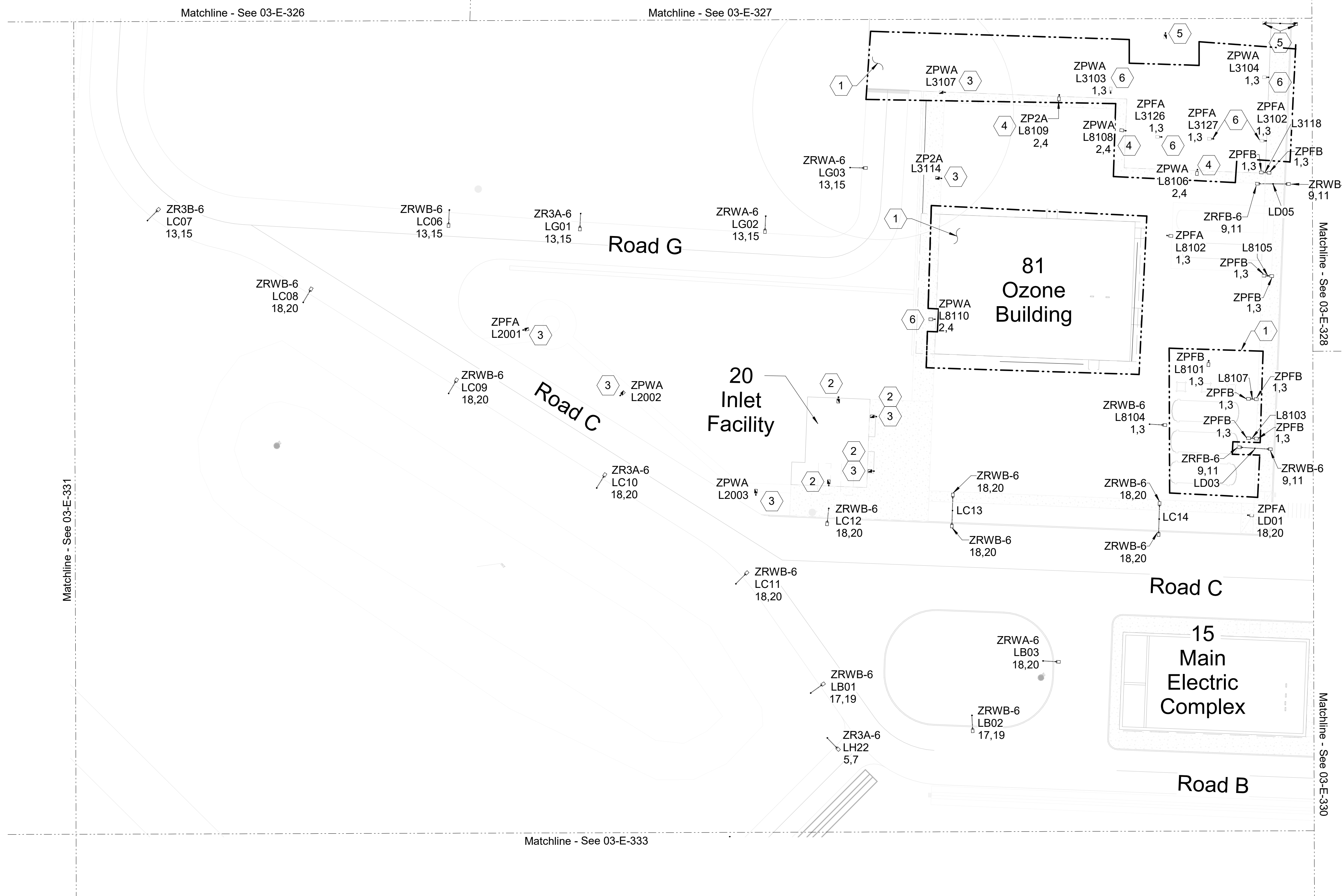

Lighting & Receptacle Plan - Grid 7

SCALE: 1" = 30'-0"

C:\Users\jdfurnia\Documents\W02229_FF_03_E_ELCON_idifurniaXJG5G.rvt

9/15/2022 3:21:01 PM

No	Date	Description	Appd
C	09/2022	Second Intermediate Design and BCOE Review - 90% Submittal	MRG
B	01/2022	Intermediate Design - 60% Submittal	MRG
A	07/2021	Initial Design - 30% Submittal	MRG
No		Revision	Appd
Survey			



Designed By	Program Mgr
Drawn By	Const Mgr
Checked By	Const Supvr
Project Mgr	Date
MRG	09/02/22

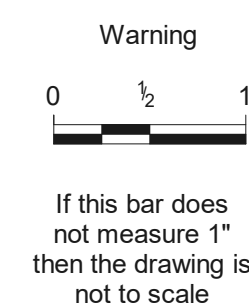

David W. Peters, Principal Engineer, PE No 16683



Date

Bull Run Filtration Facility
Electrical
 Site Lighting
 Lighting & Receptacle Plan
 Grid 7 [Exhibit A.212.ee](#)

**PRELIMINARY
NOT FOR
CONSTRUCTION**

Not for permits, pricing or other official purposes. This document has not been completed or checked and is for general information or comment only.

SAP Project No	W02229
1/4 Section	3765 / 3766
Sheet No	03-E-329
of	

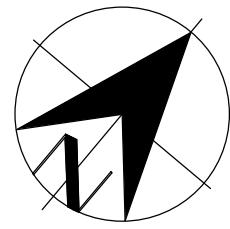

Site North

General Sheet Notes

- 480V roadway lightpoles with the road name tag shown on this sheet are powered from the building 15 panel.
- 480V pedestrian and roadway lightpoles with the area name tag are powered from the building feeding the area unless otherwise noted.
- Light pole fixture with the emergency symbol is circuited to 120V emergency panel in the building feeding power to that area. Refer to area specific plans for circuiting.
- See sheet GEN-E-142 for Lighting Controls and Controlled Receptacles Schedule and 03-E-341 for Lighting Control Plan.
- See sheets GEN-E-140 and GEN-E-141 for Luminaire Schedule.

Sheet Keynotes

- Generator enclosure exterior wallpacks and receptacle to be provided by generator manufacturer.
- See Area 51 plan for pole, light fixture, and circuiting information.
- Provide and install the light pole with fixtures under Bid Alternate except as noted. See specification section 01_23_00 Alternates.
- The light pole is circuited to area 15 panel, FF15-DP-1001.
- See Area 70 plan for pole, light fixture, and circuiting information.

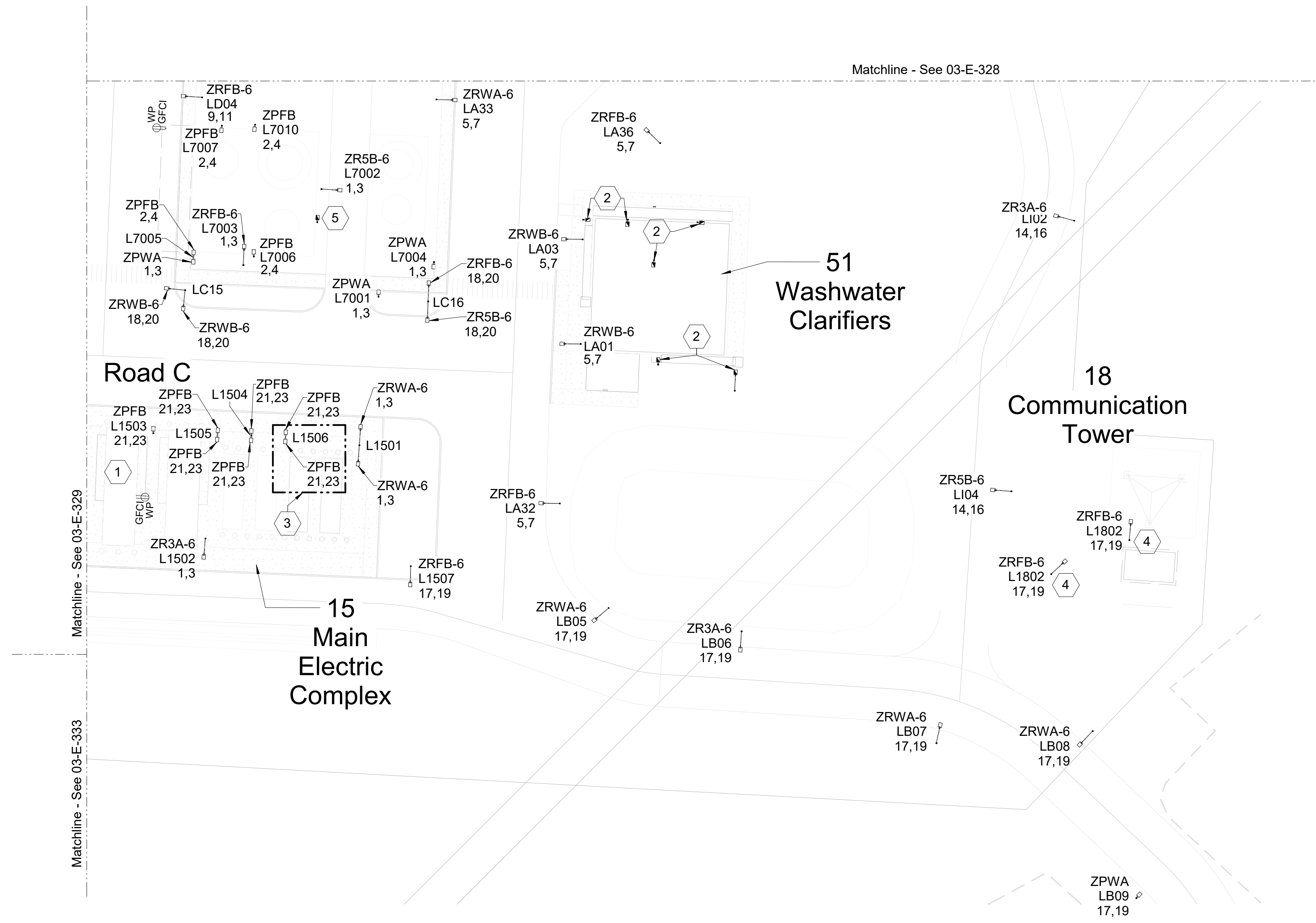

Lighting & Receptacle Plan - Grid 8

SCALE: 1" = 30'-0"

**PRELIMINARY
NOT FOR
CONSTRUCTION**

Not for permits, pricing or other official purposes. This document has not been completed or checked and is for general information or comment only.

C:\Users\jdfurina\Documents\W02229_FF_03_E_ELCON_idifurinaXJG5G.rvt

9/15/2022 3:04:22 PM

No	Date	Description	Appd
C	09/2022	Second Intermediate Design and BCOE Review - 90% Submittal	MRG
B	01/2022	Intermediate Design - 60% Submittal	MRG
A	07/2021	Initial Design - 30% Submittal	MRG
No			



Designed By	Program Mgr
Drawn By	Const Mgr
Checked By	Const Supvr
Project Mgr	Date
MRG	09/02/22

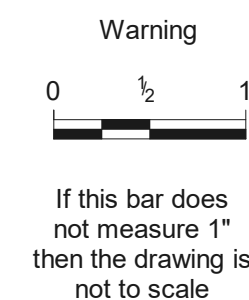

David W. Peters, Principal Engineer, PE No 16683



Bull Run Filtration Facility
Electrical
 Site Lighting
 Lighting & Receptacle Plan
 Grid 8 [Exhibit A.212.ff](#)

SAP Project No	W02229
1/4 Section	3765 / 3766
Sheet No	03-E-330
of	

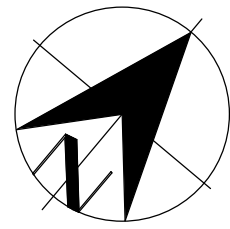

Site North

General Sheet Notes

1. 480V roadway lightpoles with the road name tag shown on this sheet are powered from building 16.
2. See sheet GEN-E-142 for Lighting Controls and Controlled Receptacles Schedule and 03-E-342 for Lighting Control Plan.
3. See sheets GEN-E-140 and GEN-E-141 for Luminaire Schedule.

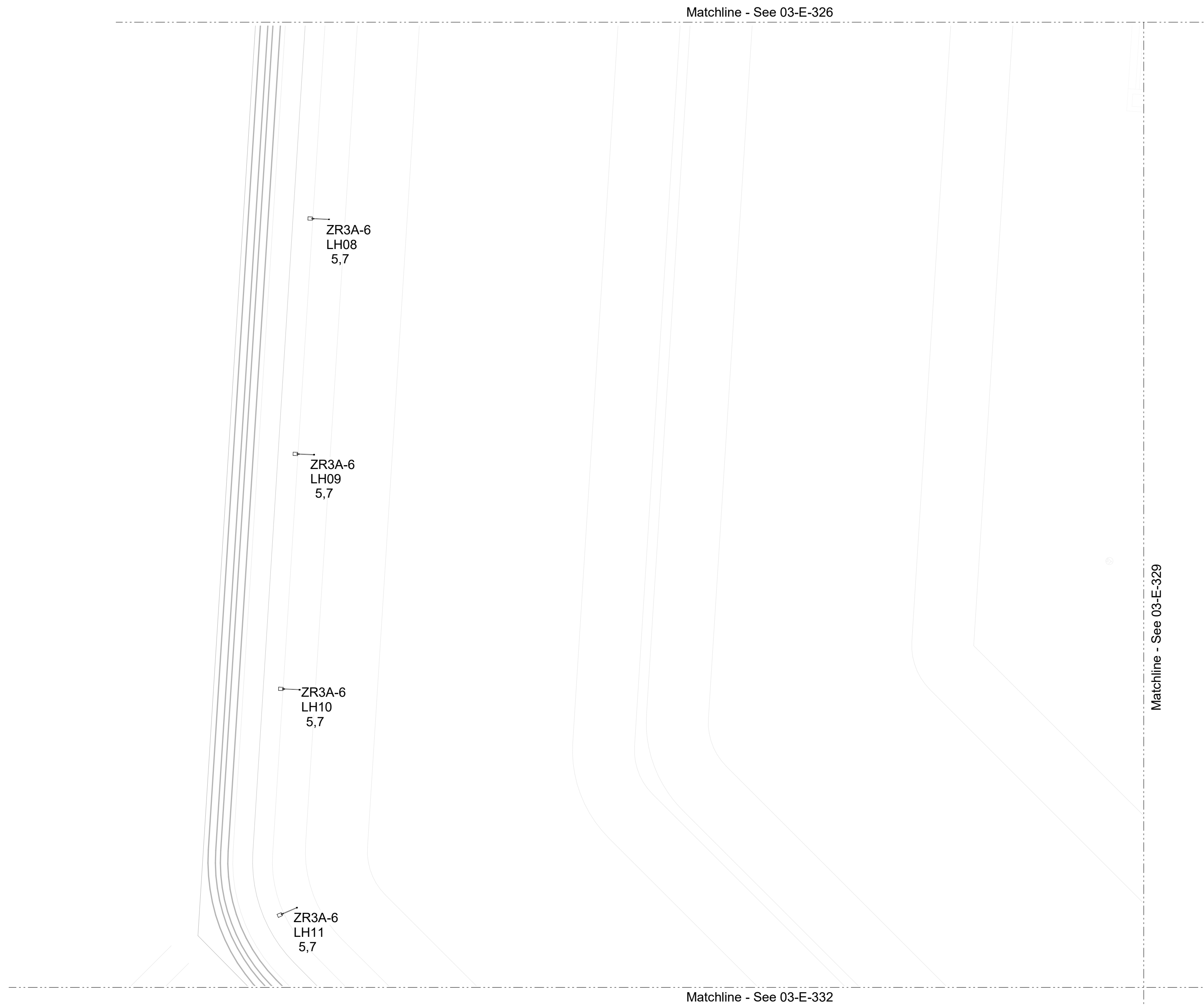

Lighting & Receptacle Plan - Grid 9

SCALE: 1" = 30'-0"

C:\Users\jdfurnia\Documents\W02229_FF_03_E_ELCON_jdfurniaXJG5G.rvt

9/15/2022 3:04:25 PM

No	Date	Description	Appd
C	09/2022	Second Intermediate Design and BCOE Review - 90% Submittal	MRG
B	01/2022	Intermediate Design - 60% Submittal	MRG
A	07/2021	Initial Design - 30% Submittal	MRG
Revision			
Survey		-	



Designed By	Program Mgr
Drawn By	Const Mgr
Checked By	Const Supvr
Project Mgr	Date
MRG	09/02/22

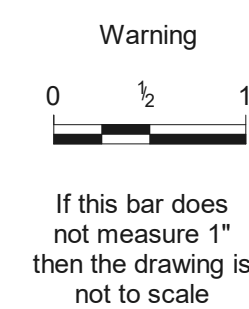

David W. Peters, Principal Engineer, PE No 16683



Date

Bull Run Filtration Facility

Electrical
 Site Lighting
 Lighting & Receptacle Plan
 Grid 9 [Exhibit A.212.gg](#)

SAP Project No	W02229
1/4 Section	3765 / 3766
Sheet No	03-E-331
of	

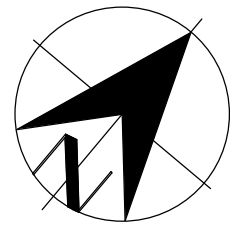

Site North

General Sheet Notes

1. 480V roadway lightpoles with the road name tag shown on this sheet are powered from building 16.
2. See sheet GEN-E-142 for Lighting Controls and Controlled Receptacles Schedule and 03-E-343 for Lighting Control Plan.
3. See sheets GEN-E-140 and GEN-E-141 for Luminaire Schedule.

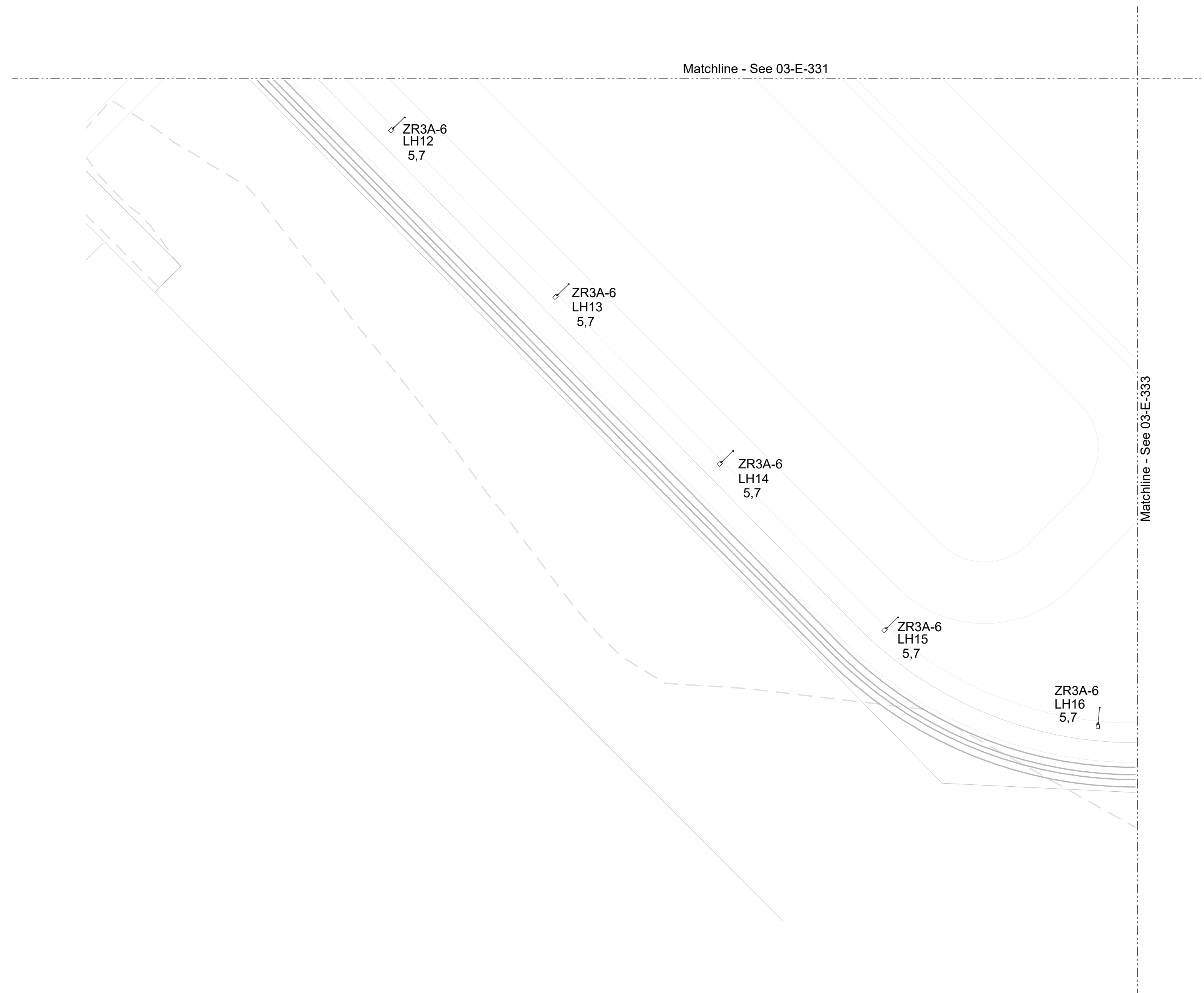

Lighting & Receptacle Plan - Grid 10

SCALE: 1" = 30'-0"

C:\Users\jdfurnia\Documents\W02229_FF_03_E_ELCON_jdfurniaXJG5G.rvt

9/15/2022 3:04:27 PM

No	Date	Description	Appd
C	09/2022	Second Intermediate Design and BCOE Review - 90% Submittal	MRG
B	01/2022	Intermediate Design - 60% Submittal	MRG
A	07/2021	Initial Design - 30% Submittal	MRG
Revision			
Survey		-	



Designed By	Program Mgr
Drawn By	Const Mgr
Checked By	Const Supvr
Project Mgr	Date
MRG	09/02/22

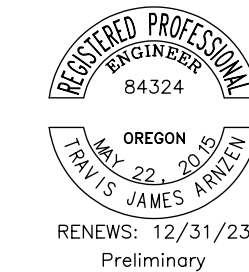
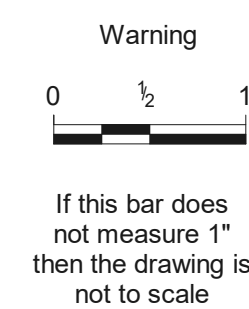

David W. Peters, Principal Engineer, PE No 16683

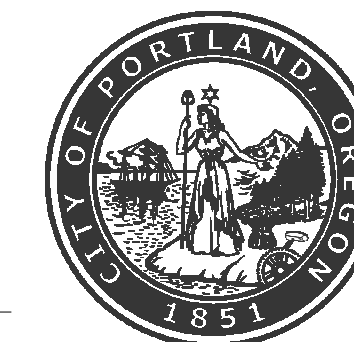

Date

Bull Run Filtration Facility

Electrical
 Site Lighting
 Lighting & Receptacle Plan
 Grid 10 [Exhibit A.212.hh](#)

SAP Project No	W02229
1/4 Section	3765 / 3766
Sheet No	03-E-332
of	

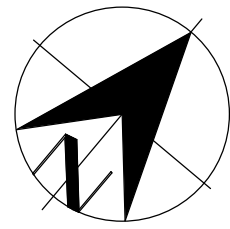

Site North

General Sheet Notes

1. 480V roadway lightpoles with the road name tag shown on this sheet are powered from building 16.
2. See sheet GEN-E-142 for Lighting Controls and Controlled Receptacles Schedule and 03-E-344 for Lighting Control Plan.
3. See sheets GEN-E-140 and GEN-E-141 for Luminaire Schedule.

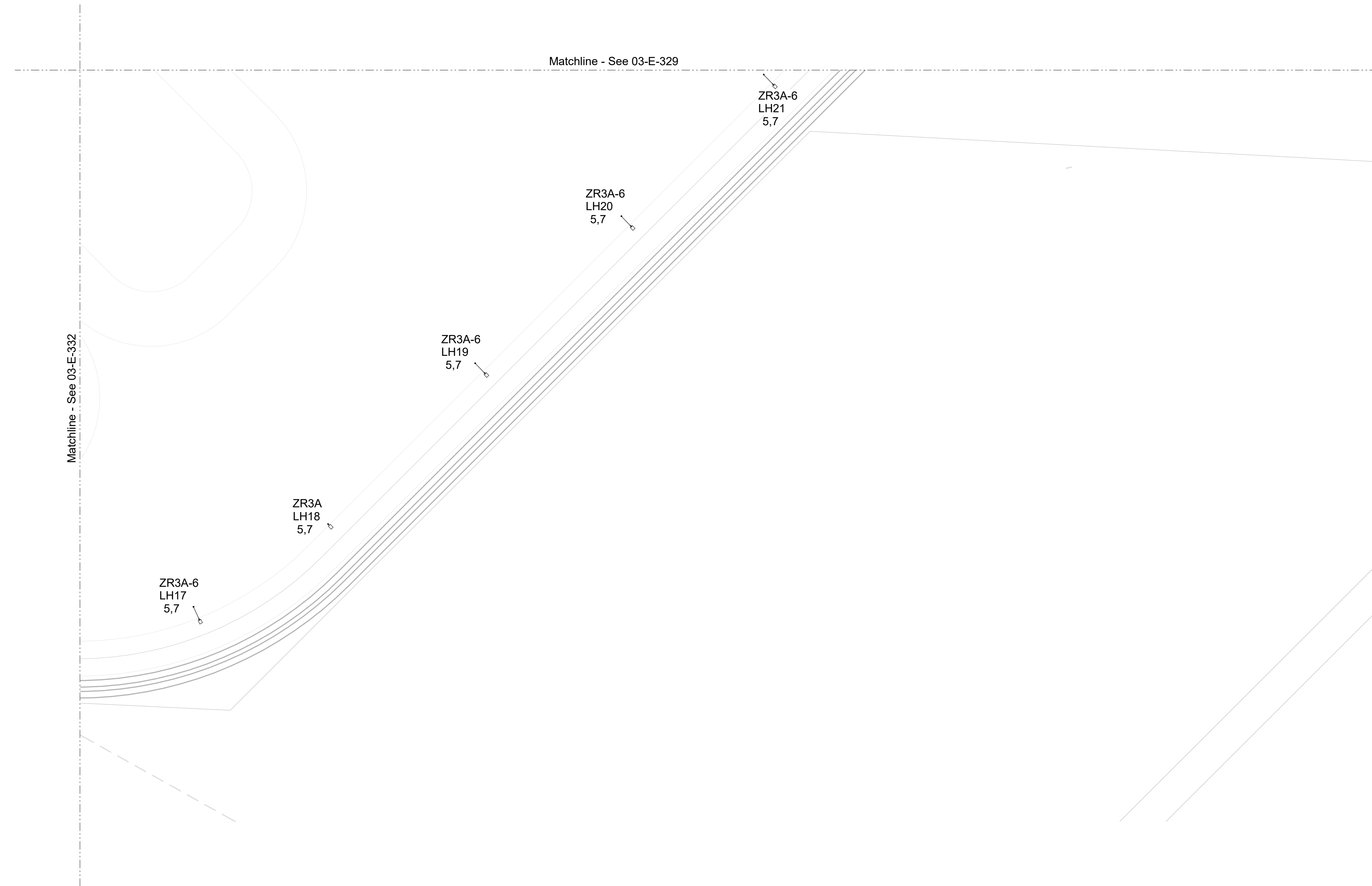

Lighting & Receptacle Plan - Grid 11

SCALE: 1" = 30'-0"

C:\Users\jdfurnia\Documents\W02229_FF_03_E_ELCON_jdfurniaXJG5G.rvt

9/15/2022 3:04:30 PM

No	Date	Description	Appd
C	09/2022	Second Intermediate Design and BCOE Review - 90% Submittal	MRG
B	01/2022	Intermediate Design - 60% Submittal	MRG
A	07/2021	Initial Design - 30% Submittal	MRG
Revision			
Survey		-	



Designed By	Program Mgr
Drawn By	Const Mgr
Checked By	Const Supvr
Project Mgr	Date
MRG	09/02/22

Warning
 0 1/2 1
 If this bar does not measure 1" then the drawing is not to scale



David W. Peters, Principal Engineer, PE No 16683



Date

Bull Run Filtration Facility
Electrical
 Site Lighting
 Lighting & Receptacle Plan
 Grid 11 [Exhibit A.212.ii](#)

SAP Project No	W02229
1/4 Section	3765 / 3766
Sheet No	03-E-333
of	

Lighting Fixture Schedule - 1

Type	Voltage	Input Power	Description	Color Temp	CRI	Delivered Lumens	Lumens Per Watt	B-U-G Rating	Finish	Mounting	Manufacturer	Series
D1	120V	13 VA	3" square recessed downlight, die-cast aluminum frame and body, flanged trim, 60deg beam spread, 0-10V 1% dimming driver.	3500	80	1100	85	N/A	White	Recessed	Zaniboni	Luna 3 AQ
D2	120V	9 VA	3" square recessed downlight, die-cast aluminum frame and body, flanged trim, 60deg beam spread, 0-10V 1% dimming driver.	3500	80	800	89	N/A	White	Recessed	Zaniboni	Luna 3 AQ
D3	120V	35 VA	5" round dead front shower downlight. Rustproof and gasketed trim assembly, white polycarbonate trim and lens, aluminum housing, 0-10V 1% dimming driver, wide beam distribution.	3500	80	1100	31	N/A	White	Recessed	Kiriln	LRR
HB1	120V	82 VA	1'x2' Linear high bay pendant, aluminum body with steel channel, DLC listed, frosted acrylic IP5X rated lens, wide distribution, 10% 0-10V dimming driver.	4000	80	11500	140	N/A	Arch to select from std finishes	Pendant	ILP	EDV
HB1D	120V	82 VA	Same as HB1 except with integral photocell.	4000	80	11500	140	N/A	Arch to select from std finishes	Pendant	ILP	EDV
HB2	120V	104 VA	1'x2' Linear high bay pendant, aluminum body with steel channel, DLC listed, frosted acrylic IP5X rated lens, wide distribution, 10% 0-10V dimming driver.	4000	80	14900	143	N/A	Arch to select from std finishes	Pendant	ILP	EDV
HB2D	120V	104 VA	Same as HB2 except with integral photocell.	4000	80	14900	143	N/A	Arch to select from std finishes	Pendant	ILP	EDV
HB3	120V	80 VA	1'x2' Vapor tight high bay pendant, fiberglass body, F1 weatherability rating, 1500 psi high pressure hosedown, 5VA flame rating, IP65, IP66, IP69 rated, DLC rated, frosted acrylic lens, wide distribution, 10% 0-10V dimming driver.	4000	80	12500	156	N/A	Arch to select from std finishes	Pendant	ILP	BL
HB4	120V	51 VA	1'x2' Linear high bay pendant, aluminum body with steel channel, DLC listed, frosted acrylic IP5X rated lens, wide distribution, 10% 0-10V dimming driver.	4000	80	7527	148	N/A	Arch to select from std finishes	Pendant	ILP	EDV
HB4D	120V	51 VA	Same as HB4 except with integral photocell.	4000	80	7527	148	N/A	Arch to select from std finishes	Pendant	ILP	EDV
L1	120V	5 VA	3" Recessed linear, high output, extruded aluminum trim with formed cold rolled 18-gauge steel back box housing, white painted steel reflector, satine acrylic high efficiency lens, powder coated trim, 0-10V 1% dimming driver. Wattage and lumens listed is per foot. See plans for fixture lengths.	3500	80	750	144	N/A	White	Recessed	Pinnacle	EV3D
L2	120V	4 VA	3" Recessed linear, standard output, extruded aluminum trim with formed cold rolled 18-gauge steel back box housing, white painted steel reflector, satine acrylic high efficiency lens, powder coated trim, 0-10V 1% dimming driver. Wattage and lumens listed is per foot. See plans for fixture lengths.	3500	80	500	143	N/A	White	Recessed	Pinnacle	EV3D
L3	120V	10 VA	3" Direct-indirect linear pendant, high output direct, standard output indirect, 6063-T6 extruded aluminum housing, die-formed white painted reflector, acrylic lens, powder coat finish, 0-10V 1% dimming driver, batwing distributions. Wattage and lumens listed is per foot. See plans for fixture lengths.	3500	80	1250	128	N/A	Arch to select from std finishes	Pendant	Pinnacle	EX3D
L4	120V	5 VA	3" Linear pendant, high output, 6063-T6 extruded aluminum housing, die-formed white painted reflector, acrylic lens, powder coat finish, 0-10V 1% dimming driver, batwing distribution. Wattage and lumens listed is per foot. See plans for fixture lengths.	3500	80	750	144	N/A	Arch to select from std finishes	Pendant	Pinnacle	EX3D
L5	120V	4 VA	3" Linear pendant, standard output, 6063-T6 extruded aluminum housing, die-formed white painted reflector, acrylic lens, powder coat finish, 0-10V 1% dimming driver, batwing distribution. Wattage and lumens listed is per foot. See plans for fixture lengths.	3500	80	500	122	N/A	Arch to select from std finishes	Pendant	Pinnacle	EX3D
L6H	120V	10 VA	3" Direct-indirect linear pendant, high output direct, standard output indirect, 6063-T6 extruded aluminum housing, die-formed white painted reflector, acrylic lens, powder coat finish, 0-10V 1% dimming driver, asymmetric distribution direct, batwing distribution indirect. Wattage and lumens listed is per foot. See plans for fixture lengths.	3500	80	1250	130	N/A	Arch to select from std finishes	Pendant	Pinnacle	EX3D
L6L	120V	8 VA	3" Direct-indirect linear pendant, standard output direct, standard output indirect, 6063-T6 extruded aluminum housing, die-formed white painted reflector, acrylic lens, powder coat finish, 0-10V 1% dimming driver, asymmetric distribution direct, batwing distribution indirect. Wattage and lumens listed is per foot. See plans for fixture lengths.	3500	80	1000	128	N/A	Arch to select from std finishes	Pendant	Pinnacle	EX3D
L7	120V	33 VA	4' Linear striplight, steel construction, frosted acrylic lens, DLC listed, 0-10V 10% dimming driver. Integral motion sensor where required. See Lighting Control Schedule.	4000	80	4300	130	N/A	Factory Standard	Pendant/Surface/Wall	ILP	FZ
L7D	120V	33 VA	Same as L7 except with integral photocell. Additional integral motion sensor where required. See Lighting Control Schedule.	4000	80	4300	130	N/A	Factory Standard	Pendant/Surface/Wall	ILP	FZ
L8	120V	54 VA	4' Linear striplight, steel construction, frosted acrylic lens, DLC listed, 0-10V 10% dimming driver. Integral motion sensor where required. See Lighting Control Schedule.	4000	80	7300	135	N/A	Factory Standard	Pendant/Surface/Wall	ILP	FZ
L8D	120V	54 VA	Same as L8 except with integral photocell. Additional integral motion sensor where required. See Lighting Control Schedule.	4000	80	7300	135	N/A	Factory Standard	Pendant/Surface/Wall	ILP	FZ
L9	120V	38 VA	48" Linear vapor tight, fiberglass body with 51 weatherability rating & 5VA flame rating, IP67, NEMA4x, & 1500 PSI Hosedown, ETL listed for wet location, DLC listed, shallow acrylic frosted lens, 0-10V 10% dimming driver.	4000	80	5100	134	N/A	Factory Standard		ILP	
L10	120V	6 VA	3" Led linear wall wash, standard output, extruded aluminum flanged trim with formed cold rolled 20 gauge steel back box housing, die-formed white painted steel reflector, diffuse acrylic lens, powder-coat textured finish, 0-10V 1% dimming driver, wall wash distribution. Wattage and lumens listed is per foot. See plans for fixture lengths.	3500	80	343	57	N/A	White	Recessed	Pinnacle	EV3WW
L11	120V	10 VA	3" Led linear wall wash, high output, extruded aluminum flanged trim with formed cold rolled 20 gauge steel back box housing, die-formed white painted steel reflector, diffuse acrylic lens, powder-coat textured finish, 0-10V 1% dimming driver, wall wash distribution. Wattage and lumens listed is per foot. See plans for fixture lengths.	3500	80	534	52	N/A	White	Recessed	Pinnacle	EV3WW
LP1	120V	45 VA	2'x4' Flat lens volumetric troffer, lightweight aluminum body, impact & scratch resistant PMMA frosted acrylic lens, 0-10v 1% dimming driver.	4000	80	4800	107	N/A	White	Recessed	ILP	FLT
LP1D	120V	45 VA	2'x4' Flat lens volumetric troffer, lightweight aluminum body, impact & scratch resistant PMMA frosted acrylic lens, integral photocell, 0-10v 1% dimming driver.	4000	80	4800	107	N/A	White	Recessed	ILP	FLT
LP2	120V	30 VA	2'x2' flat lens volumetric troffer, lightweight aluminum body, impact & scratch resistant PMMA frosted acrylic lens, 0-10V 1% dimming driver.	4000	80	3500	117	N/A	White	Recessed	ILP	FLT
LP2D	120V	30 VA	2'x2' flat lens volumetric troffer, lightweight aluminum body, impact & scratch resistant PMMA frosted acrylic lens, integral photocell, 0-10V 1% dimming driver.	4000	80	3500	117	N/A	White	Recessed	ILP	FLT
P1	120V	3 VA	2.5" Dia round cylinder pendant, die-cast aluminum body, 60deg beam spread, solite lens, 0-10V 1% dimming driver integral to canopy.	3500	80	370	123	N/A	Arch to select from std finishes	Pendant	Zaniboni	
P2	120V	154 VA	6'x6'x3" Linear square direct-indirect pendant, medium output direct, low output direct, one-piece heavy gauge 6063 extruded aluminum housing, microstructure edge tech optics, batwing distributions, 0-10V 1% dimming driver.	3500	80	18600	121	N/A	Arch to select from std finishes	Pendant	Extant	Huntington 3
P3	120V	17 VA	24" Direct round led pendant, low output, rolled and welded aluminum housing, die-formed white painted steel reflector, single piece flush satine lens, powder-coat textured finish, 0-10v dimming driver.	3500	80	1800	108	N/A	Arch to select from std finishes	Pendant	Pinnacle	Fina F24D
P4	120V	12 VA	18" Direct round led pendant, low output, rolled and welded aluminum housing, die-formed white painted steel reflector, single piece flush satine lens, powder-coat textured finish, 0-10V dimming driver.	3500	80	1300	107	N/A	Arch to select from std finishes	Pendant	Pinnacle	Fina F18D
R1	120V	9 VA	14" Recessed direct architectural round pendant, low output, extruded aluminum housing, highly reflective die-formed white painted steel reflector, flush satine lens, flanged trim, 0-10V 1% dimming driver.	80	80	800	88	N/A	Arch to select from std finishes		Pinnacle	Fina F14D
R2	120V	17 VA	24" Recessed direct architectural round pendant, low output, extruded aluminum housing, highly reflective die-formed white painted steel reflector, flush satine lens, flanged trim, 0-10V 1% dimming driver.	3500	80	1800	108	N/A	White	Recessed	Pinnacle	Fina F24D
R3	120V	44 VA	36" Recessed direct architectural round pendant, low output, extruded aluminum housing, highly reflective die-formed white painted steel reflector, flush satine lens, flanged trim, 0-10V 1% dimming driver.	3500	80	4800	109	N/A	Arch to select from std finishes	Recessed	Pinnacle	Fina F36D
UC1	120V	8 VA	18" Surface mount undercabinet light, extruded aluminum low profile housing, integral pir sensor, 5% ELV dimming.	3500	90	440	54	N/A	Arch to select from std finishes	Surface	Halo	HU30
UC2	120V	4 VA	9" Surface mount undercabinet light, extruded aluminum low profile housing, integral pir sensor, 5% ELV dimming.	3500	90	220	59	N/A	Arch to select from std finishes	Surface	Halo	HU30
W1	120V	18 VA	24" Wall mount vanity, high output, heavy gauge extruded aluminum, impact resistant co-extruded frosted white lens, 0-10V 1% dimming driver.	3500	80	1900	106	N/A	Arch to select from std finishes	Wall Mount	Birchwood	NOL-LED
WA1D	120V	129 VA	Wall pack, die-cast aluminum heat sink, patented high-efficiency injection-molded Acculed optics, TGIC polyester powder coat paint, 0-10V dimming driver, Type 4 forward throw distribution.	4000	70	16200	126	B2-U0-G3	Arch to select from std finishes	Wall	McGraw-Edison	GWC
X1B	120V	1 VA	Illuminated Exit Sign, aluminum housing, high impact acrylic panel, single & double sided lenses included, clear, mirror, & white insert included, field installed and NFPA 101 compliant chevron directional indicators, 6" red letters.						Brushed Aluminum	Back Mounted	Cooper AtLite	AUX
X1S	120V	1 VA	Illuminated Exit Sign, aluminum housing, high impact acrylic panel, single & double sided lenses included, clear, mirror, & white insert included, field installed and NFPA 101 compliant chevron directional indicators, 6" red letters.						Brushed Aluminum	Side Mounted	Cooper AtLite	AUX
ZA1	120V	21 VA	Adjustable accent, nominal 12.6" long x 3.6" dia, cylindrical die cast aluminum housing, 20 degree 50% beamsread, 9500 max candela, 180 degree tilt, 0-10v dimming capability, integral driver, 45 degree angle cut cap, softening lens, IP66 wet location rated, thermoset powder coat finish. See lighting drawings for number of heads on pole.	3000	80	1300	62	N/A	Arch to select from std finishes	Pole	Hydrel	SAF1 (fixture) AMHM (mount) AMPC (pole clamp)
ZC1	120V	28 VA	18" Diameter led pendant, die-cast aluminum housing, integral motion sensor and photocell for bi-level switching, solite glass lens, powder coat finish, 0-10v dimming driver, concentrated type CQ distribution, integral wavelinx wireless sensor, bird guard, pendant stem with 30 degree hang straight swivel at canopy, contractor to specify quantity and location of threaded taps on j-boxes.	3000	80	3400	121	B1-U0-G1	Arch to select from std finishes	Pendant	McGraw-Edison (fixture) HK Lighting (j-box)	Top Tier (fixture) CCB5.3 (j-box)

**PRELIMINARY
NOT FOR
CONSTRUCTION**

Not for permits, pricing or other official purposes. This document has not been completed or checked and is for general information or comment only.

C:\Users\jifuria\Documents\Lighting_Junkyard_jifuriaX\IG5G.nt

8/31/2022 3:21:32 PM

No	Date	Description	Appd
C	09/2022	Second Intermediate Design and BCOE Review - 90% Submittal	MRG
B	01/2022	Intermediate Design - 60% Submittal	MRG
A	07/2021	Initial Design - 30% Submittal	MRG
Revision			
Survey			



Designed By	Program Mgr
Drawn By	Const Mgr
Checked By	Const Supvr
Project Mgr	Date
MRG	09/02/22

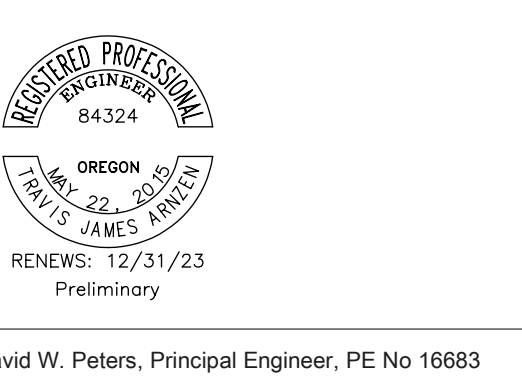
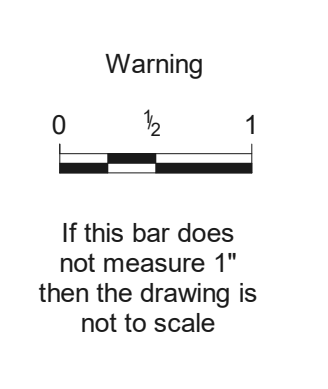

Bull Run Filtration Facility

Electrical

General
Lighting Schedule - 1

SAP Project No
W02229

1/4 Section
3765 / 3766

Sheet No
GEN-E-140

of

Exhibit A.212.jj

Lighting Fixture Schedule - 2

Type	Voltage	Input Power	Description	Color Temp	CRI	Delivered Lumens	Lumens Per Watt	B-U-G Rating	Finish	Mounting	Manufacturer	Series
ZC1H	120V	75 VA	18" Diameter led pendant, die-cast aluminum housing, integral motion sensor and photocell for bi-level switching, solite glass lens, powder coat finish, 0-10v dimming driver, concentrated type CQ distribution, integral wavelinx wireless sensor, bird guard, pendant stem with 30 degree hang straight swivel at canopy, contractor to specify quantity and location of threaded taps on j-boxes.	3000	80	8300	111	B3-U0-G1	Arch to select from std finishes	Pendant	Mcgraw-Edison (fixture) HK Lighting (j-box)	Top Tier (fixture) CCB5.3 (j-box)
ZC2	120V	11 VA	4" Shallow square downlight, 2.75" max depth above ceiling, UL wet listed, rustproof acrylic enameled aluminum housing, white self-flanged regressed trim with clear microprismatic lens, 0-10V 1% dimming driver, wide 65 degree 50% beam distribution.	3000	80	1000	91	B2-U0-G0	Arch to select from std finishes	Recessed	Kirlin	LRC-04SDN
ZC4H	120V	36 VA	Exterior 4" linear direct fixture, heavy gauge 4" square extruded aluminum housing, frosted white impact resistant extruded lens, UL listed for wet locations, 0-10v dimming drive. Provide bird spikes on top surface of fixture.	3000	80	2800	78	B1-U0-G1	Arch to select from std finishes	Cable Suspension	Birchwood	VAN-LED-400
ZC4M	120V	36 VA	Exterior 4" linear direct fixture, heavy gauge 4" square extruded aluminum housing, frosted white impact resistant extruded lens, powder coat finish, UL listed for wet locations, 0-10v dimming driver, provide bird spikes on top surface of fixture.	3000	80	2800	78	B1-U0-G1	Arch to select from std finishes	Mullion / Side mount	Birchwood	VAN-LED-400
ZC4S	120V	36 VA	Exterior 4" linear direct fixture, heavy gauge 4" square extruded aluminum housing, frosted white impact resistant extruded lens, powder coat finish, UL listed for wet locations, 0-10v dimming driver.	3000	80	2800	78	B1-U0-G1	Arch to select from std finishes	Mullion / Side mount	Birchwood	VAN-LED-400
ZD2F	120V	10 VA	Exterior decorative door light, nominal 9" wide x 8" tall x 5.5" deep die cast aluminum housing, thermoset powder coat finish, wedge profile, non-pixelated light source, forward throw beamspread, UL listed for wet locations, 0-10v dimming capability, full cutoff. Provide back box option as needed for surface mounted conduit connection.	3000	80	1100	110	B0-U0-G0	Arch to select from std finishes	Wall	Lithonia	WDGE1
ZD2W	120V	10 VA	Exterior decorative door light, nominal 9" wide x 8" tall x 5.5" deep die cast aluminum housing, thermoset powder coat finish, wedge profile, non-pixelated light source, wide beamspread, UL listed for wet locations, 0-10v dimming capability, full cutoff. Provide back box option as needed for surface mounted conduit connection.	3000	80	1100	110	B0-U0-G0	Arch to select from std finishes	Wall	Lithonia	WDGE1
ZD3	120V	15 VA	Exterior ADA door light, nominal 11-7/8" wide x 4-3/8" tall x 3-3/8" deep die cast aluminum housing, convex arc top profile, matte safety glass lens, Type 2 very short distribution, UL listed for wet locations, 0-10v dimming driver, nominal 85 degree 50% beamspread, full cutoff.	3000	80	1050	70	B1-U0-G0	Arch to select from std finishes	Wall	Bega	24374
ZEP2	120V	34 VA	Exterior pedestrian light, die-cast aluminum housing and heat sink, houseside shield, 7-pin nema receptacle, integral outdoor control module and wireless sensor, patented high-efficiency injection molded Acculed optics, TGIC polyester powder coat finish, 0-10V dimming driver, Type 2 with spill control distribution, quick mount 5" arm.	3000	80	3200	94	B0-U0-G1	Arch to select from std finishes	Pole / Arm	McGraw-Edison	GPC
ZEPC	120V	17 VA	Exterior pedestrian light, die-cast aluminum housing and heat sink, houseside shield, 7-pin nema receptacle, integral outdoor control module and wireless sensor, patented high-efficiency injection molded Acculed optics, TGIC polyester powder coat finish, 0-10V dimming driver, Type 4 wide distribution, modified lumen output, quick mount 5" arm.	3000	80	1400	82	B0-U0-G1	Arch to select from std finishes	Pole / Arm	McGraw-Edison	GPC
ZEPF	120V	34 VA	Exterior pedestrian light, die-cast aluminum housing and heat sink, houseside shield, 7-pin nema receptacle, integral outdoor control module and wireless sensor, patented high-efficiency injection molded Acculed optics, TGIC polyester powder coat finish, 0-10V dimming driver, Type 4 forward throw distribution, quick mount 5" arm.	3000	80	2800	82	B0-U0-G1	Arch to select from std finishes	Pole / Arm	McGraw-Edison	GPC
ZEPG	120V	44 VA	Exterior pedestrian light, die-cast aluminum housing and heat sink, houseside shield, 7-pin nema receptacle, integral outdoor control module and wireless sensor, patented high-efficiency injection molded Acculed optics, TGIC polyester powder coat finish, 0-10v dimming driver, Type 4 forward throw distribution, quick mount 5" arm.	3000	80	3400	77	B1-U0-G1	Arch to select from std finishes	Pole / Arm	McGraw-Edison	GPC
ZEPW	120V	34 VA	Exterior pedestrian light, die-cast aluminum housing and heat sink, houseside shield, 7-pin nema receptacle, integral outdoor control module and wireless sensor, patented high-efficiency injection molded Acculed optics, TGIC polyester powder coat finish, 0-10v dimming driver, Type 4 wide distribution, quick mount 5" arm.	3000	80	2800	82	B0-U0-G1	Arch to select from std finishes	Pole / Arm	McGraw-Edison	GPC
ZERW-6	120V	44 VA	Exterior area light, die-cast aluminum housing and heat sink, houseside shield, 7-pin nema receptacle, integral wireless sensor, patented high-efficiency injection molded Acculed optics, TGIC polyester powder coat finish, 0-10v dimming driver, Type 4 wide distribution, 6 ft steel mast arm.	3000	80	3300	75	B0-U0-G1	Arch to select from std finishes	Pole / Arm	McGraw-Edison	GALN
ZF1	120V	52 VA	Exterior floodlight, nominal 17" long x 10.35" wide x 4" deep extruded aluminum housing, 0-90 degree tilt, trunnion mount bracket, UV stable clear polycarb lens, powder coat finish, 0-10V dimming driver, 7-pin NEMA receptacle, type 4 beamspread, nominal 0.58 EPA at 0 degree tilt above nadir, full cutoff aiming angle.	3000	70	8100	156		Arch to select from std finishes	Surface / Eaves	Linmore LED	LL-SL1
ZP2A	480V	34 VA	Exterior pedestrian light, die-cast aluminum housing and heat sink, houseside shield, 7-pin nema receptacle, integral outdoor control module and wireless sensor, patented high-efficiency injection molded Acculed optics, TGIC polyester powder coat finish, 0-10v dimming driver, Type 2 with spill control distribution, quick mount 5" arm.	3000	80	3200	94	B0-U0-G1	Arch to select from std finishes	Pole / Arm	McGraw-Edison	GPC
ZP2C	480V	17 VA	Exterior pedestrian light, die-cast aluminum housing and heat sink, houseside shield, 7-pin nema receptacle, integral wireless sensor, patented high-efficiency injection molded Acculed optics, TGIC polyester powder coat finish, 0-10v dimming driver, Type 2 with spill control distribution, modified lumen output, quick mount 5" arm.	3000	80	1600	94	B0-U0-G1	Arch to select from std finishes	Pole / Arm	McGraw-Edison	GPC
ZPFA	480V	34 VA	Exterior pedestrian light, die-cast aluminum housing and heat sink, houseside shield, 7-pin nema receptacle, integral outdoor control module and wireless sensor, patented high-efficiency injection molded Acculed optics, TGIC polyester powder coat finish, 0-10v dimming driver, Type 4 forward throw distribution, quick mount 5" arm.	3000	80	2800	82	B0-U0-G1	Arch to select from std finishes	Pole / Arm	McGraw-Edison	GPC
ZPFB	480V	44 VA	Exterior pedestrian light, die-cast aluminum housing and heat sink, houseside shield, 7-pin nema receptacle, integral outdoor control module and wireless sensor, patented high-efficiency injection molded Acculed optics, TGIC polyester powder coat finish, 0-10v dimming driver, Type 4 forward throw distribution, quick mount 5" arm.	3000	80	3400	77	B1-U0-G1	Arch to select from std finishes	Pole / Arm	McGraw-Edison	GPC
ZPWA	480V	34 VA	Exterior pedestrian light, die-cast aluminum housing and heat sink, houseside shield, 7-pin nema receptacle, integral outdoor control module and wireless sensor, patented high-efficiency injection molded Acculed optics, TGIC polyester powder coat finish, 0-10v dimming driver, Type 4 wide distribution, quick mount 5" arm.	3000	80	2800	82	B0-U0-G1	Arch to select from std finishes	Pole / Arm	McGraw-Edison	GPC
ZPWC	480V	17 VA	Exterior pedestrian light, die-cast aluminum housing and heat sink, houseside shield, 7-pin nema receptacle, integral outdoor control module and wireless sensor, patented high-efficiency injection molded Acculed optics, TGIC polyester powder coat finish, 0-10v dimming driver, Type 4 wide distribution, modified lumen output, quick mount 5" arm.	3000	80	1400	82	B0-U0-G1	Arch to select from std finishes	Pole / Arm	McGraw-Edison	GPC
ZR3A	480V	33 VA	Exterior area light, die-cast aluminum housing and heat sink, houseside shield, 7-pin nema receptacle, integral wireless sensor, patented high-efficiency injection molded Acculed optics, TGIC polyester powder coat finish, 0-10v dimming driver, Type 3R roadway distribution, quick mount 9" arm.	3000	80	2800	85	B0-U0-G1	Arch to select from std finishes	Pole / Arm	McGraw-Edison	GALN
ZR3A-6	480V	33 VA	Exterior area light, die-cast aluminum housing and heat sink, houseside shield, 7-pin nema receptacle, integral wireless sensor, patented high-efficiency injection molded Acculed optics, TGIC polyester powder coat finish, 0-10v dimming driver, Type 3R roadway distribution, 6 ft steel mast arm.	3000	80	2800	85	B0-U0-G1	Arch to select from std finishes	Pole / Arm	McGraw-Edison	GALN
ZR3B-6	480V	44 VA	Exterior area light, die-cast aluminum housing and heat sink, houseside shield, 7-pin nema receptacle, integral wireless sensor, patented high-efficiency injection molded Acculed optics, TGIC polyester powder coat finish, 0-10v dimming driver, Type 3R roadway distribution, 6 ft steel mast arm.	3000	80	3500	80	B1-U0-G1	Arch to select from std finishes	Pole / Arm	McGraw-Edison	GALN
ZR5B-6	480V	44 VA	Exterior area light, die-cast aluminum housing and heat sink, houseside shield, 7-pin nema receptacle, integral wireless sensor, patented high-efficiency injection molded Acculed optics, TGIC polyester powder coat finish, 0-10v dimming driver, Type 5 wide distribution, 6 ft steel mast arm.	3000	80	4700	107	B3-U0-G1	Arch to select from std finishes	Pole / Arm	McGraw-Edison	GALN
ZRFB-6	480V	44 VA	Exterior area light, die-cast aluminum housing and heat sink, houseside shield, 7-pin nema receptacle, integral wireless sensor, patented high-efficiency injection molded Acculed optics, TGIC polyester powder coat finish, 0-10v dimming driver, Type 4 forward throw distribution, 6 ft steel mast arm.	3000	80	3200	73	B0-U0-G1	Arch to select from std finishes	Pole / Arm	McGraw-Edison	GALN
ZRWA-6	480V	33 VA	Exterior area light, die-cast aluminum housing and heat sink, houseside shield, 7-pin nema receptacle, integral wireless sensor, patented high-efficiency injection molded Acculed optics, TGIC polyester powder coat finish, 0-10v dimming driver, Type 4 wide distribution, 6 ft steel mast arm.	3000	80	2800	85	B0-U0-G1	Arch to select from std finishes	Pole / Arm	McGraw-Edison	GALN
ZRWB-6	480V	44 VA	Exterior area light, die-cast aluminum housing and heat sink, houseside shield, 7-pin nema receptacle, integral wireless sensor, patented high-efficiency injection molded Acculed optics, TGIC polyester powder coat finish, 0-10v dimming driver, Type 4 wide distribution, 6 ft steel mast arm.	3000	80	3300	75	B0-U0-G1	Arch to select from std finishes	Pole / Arm	McGraw-Edison	GALN
ZS1	120V	22 VA	Submersible floodlight, 316 marine grade stainless steel housing, 300 degree tilt, fully sealed and gasketed, IP68 at 10m/32.8 ft, powered by remote 100 watt transformer in stainless steel nema 3r housing (1 fixture per transformer), 20x40 degree horizontal 50% beamspread. See lighting details for fixture mounting to column/winch assembly to adjust mounting height. See lighting details for transformer mounting.	4300	80	1100	50	N/A	Arch to select from std finishes	Custom Column / Winch (fixture), Rail (Transformer)	Lumascap	LS365LED (fixture) LS-TSS-100 (Transformer)
ZWFA	120V	34 VA	Exterior wall pack, die-cast aluminum housing and heat sink, houseside shield, integral motion sensor and photocell for bi-level switching, patented high-efficiency injection molded Acculed optics, TGIC polyester powder coat finish, Type 4 forward throw distribution.	3000	80	2800	82	B0-U0-G1	Arch to select from std finishes	Wall	McGraw-Edison	GWC
ZWFB	120V	44 VA	Exterior wall pack, die-cast aluminum heat sink, patented high-efficiency injection-molded Acculed optics, TGIC polyester powder coat paint, 0-10V dimming driver, Type 4 forward throw distribution.	3000	80	3400	77	B1-U0-G1	Arch to select from std finishes	Wall	McGraw-Edison	GWC
ZWWA	120V	34 VA	Exterior wall pack, die-cast aluminum heat sink, patented high-efficiency injection-molded Acculed optics, TGIC polyester powder coat paint, 0-10V dimming driver, Type 4 wide distribution.	3000	80	2800	82	B0-U0-G1	Arch to select from std finishes	Wall	McGraw-Edison	GWC
ZWWB	120V	44 VA	Exterior wall pack, die-cast aluminum housing and heat sink, houseside shield, 7-pin Nema receptacle, integral motion sensor and photocell for bi-level switching, patented high-efficiency injection molded Acculed optics, TGIC polyester powder coat finish, 0-10V dimming driver, Type 4 wide distribution.	3000	80	3500	80	B0-U0-G1	Arch to select from std finishes	Wall	McGraw-Edison	GWC

**PRELIMINARY
NOT FOR
CONSTRUCTION**

Not for permits, pricing or other official purposes. This document has not been completed or checked and is for general information or comment only.

C:\Users\jdfurria\Documents\Lighting_Junkyard_jdfurriaX\IG5G.nt

9/15/2022 3:43:41 PM

C	09/2022	Second Intermediate Design and BCOE Review - 90% Submittal	MRG
B	01/2022	Intermediate Design - 60% Submittal	MRG
A	07/2021	Initial Design - 30% Submittal	MRG
No	Date	Description	Appd
Revision			
Survey			



Stantec



ELCON ASSOCIATES, INC.

Designed By	Program Mgr	DVP
Drawn By	Const Mgr	TC
Checked By	Const Supvr	RM
Project Mgr	Date	09/02/22



PORTLAND WATER BUREAU

FROM FOREST TO FAUCET

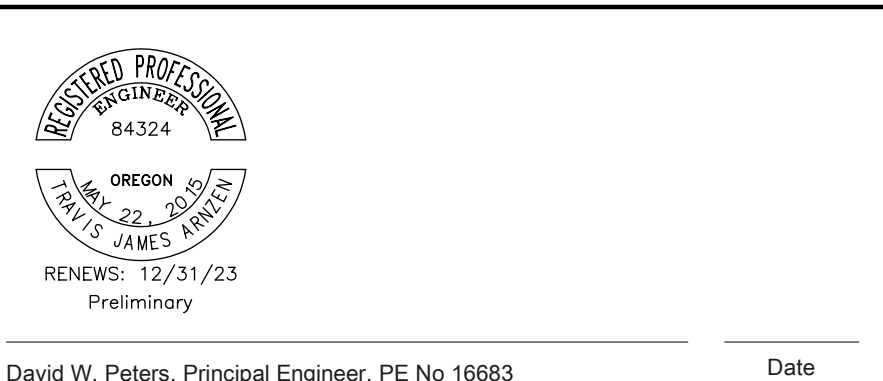

REGISTERED PROFESSIONAL ENGINEER
84324
OREGON
EXPIRES 12/31/23
Preliminary

David W. Peters, Principal Engineer, PE No 16683



Bull Run Filtration Facility

Electrical

General Lighting Schedule - 2

Exhibit A.212.kk

SAP Project No
W02229

1/4 Section
3765 / 3766

Sheet No
GEN-E-141

of

Lighting Fixture Schedule - 3

Type	Voltage	Input Power	Description	Color Temp	CRI	Delivered Lumens	Lumens Per Watt	B-U-G Rating	Finish	Mounting	Manufacturer	Series
ZX1B	120V	1 VA	Exterior exit sign, single-face, pvc frame, polycarbonate faceplate, heavy aluminum backplate, white with green letters, field selectable chevrons, UL listed for wet locations, back mounted.						Arch to select from std finishes	Back Mounted	Emergi-lite	SVX
ZX1P	120V	1 VA	Exterior exit sign, single-face, pvc frame, polycarbonate faceplate, heavy aluminum backplate, white with green letters, field selectable chevrons, UL listed for wet locations, pendant mounted.						Arch to select from std finishes	Pendant	Emergi-lite	SVX
ZX1S	120V	1 VA	Exterior exit sign, single-face, pvc frame, polycarbonate faceplate, heavy aluminum backplate, white with green letters, field selectable chevrons, UL listed for wet locations, side mounted.						Arch to select from std finishes	Side Mounted	Emergi-lite	SVX
ZX2P	120V	1 VA	Exterior exit sign, double-face, pvc frame, polycarbonate faceplate, heavy aluminum backplate, white with green letters, field selectable chevrons, UL listed for wet locations, pendant mounted.						Arch to select from std finishes	Pendant	Emergi-lite	SVX
ZX2S	120V	1 VA	Exterior exit sign, double-face, pvc frame, polycarbonate faceplate, heavy aluminum backplate, white with green letters, field selectable chevrons, UL listed for wet locations, side mounted.						Arch to select from std finishes	Side Mounted	Emergi-lite	SVX

C:\Users\jdfurria\Documents\Lighting_Junkyard_jdfurriaXIG5G.nt

8/31/2022 3:21:35 PM

No	Date	Description	Appd
C	09/2022	Second Intermediate Design and BCOE Review - 90% Submittal	MRG
B	01/2022	Intermediate Design - 60% Submittal	MRG
A	07/2021	Initial Design - 30% Submittal	MRG
Revision			
Survey		-	



Designed By	Program Mgr
Drawn By	Const Mgr
Checked By	Const Supvr
Project Mgr	Date
MRG	09/02/22

Warning

If this bar does not measure 1" then the drawing is not to scale



David W. Peters, Principal Engineer, PE No 16683

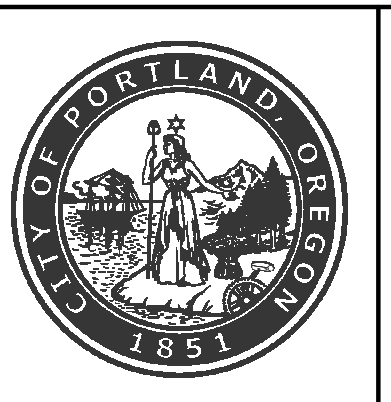

Bull Run Filtration Facility

Electrical

General
Lighting Schedule - 3

[Exhibit A.212.11](#)

SAP Project No	W02229
1/4 Section	3765 / 3766
Sheet No	GEN-E-142
of	