

NOTICE OF DECISION



www.multco.us/landuse ▪ Email: land.use.planning@multco.us ▪ Phone: (503) 988-3043

Application for Planning Director's Decision, New Forest Dwelling, Forest Development Standards, and Exception to the Secondary Fire Safety Zone

Case File: T2-2025-0035

Applicant: Andrew Lightcap

Proposal: Request for a Planning Director's Decision to establish a farm use and agricultural building and New Forest Dwelling, Forest Development Standards, and Exception to the Secondary Fire Safety Zone to establish a new single-family dwelling utilizing the template test, accessory buildings, accessory structures (septic system including pipes and drainfield and stormwater drainage control system), and private driveway.

Location: No situs address along NW Newberry Road, Portland **Property ID #** R325446

Map, Tax lot: 2N1W33A -00600

Alt. Acct. # R971330150

Base Zone: Commercial Forest Use – 2 (CFU-2)

Overlays: Geologic Hazards (GH)
Significant Wildlife Habitats (SEC-h)
Significant Streams (SEC-s)
Significant Scenic Views (SEC-v)

Decision: Approved with Conditions

This decision is final at the close of the appeal period, unless appealed. The deadline for filing an appeal is Tuesday, June 23, 2026 at 4:00 pm.

Issued by:

A handwritten signature in black ink, appearing to read "RITHY KHUT", written over a horizontal line.

Digitally signed by Rithy Khut
DN: cn=Rithy Khut, o=Multnomah
County, ou=Department of
Community Services,
email=rithy.khut@multco.us, c=US

Rithy Khut, Senior Planner

For: Megan Gibb,
Planning Director

Date: Tuesday, June 9, 2026

Instrument Number for Recording
Purposes: # 2011-138576

Opportunity to Review the Record: The complete case file and all evidence associated with this application is available for review by contacting LUP-comments@multco.us. Paper copies of all documents are available at the rate of \$0.71/page.

Opportunity to Appeal: The appeal form is available at www.multco.us/landuse/application-materials-and-forms. Email the completed appeal form to LUP-submittals@multco.us. An appeal requires a \$250.00 fee and must state the specific legal grounds on which it is based. This decision is not appealable to the Land Use Board of Appeals until all local appeals are exhausted.

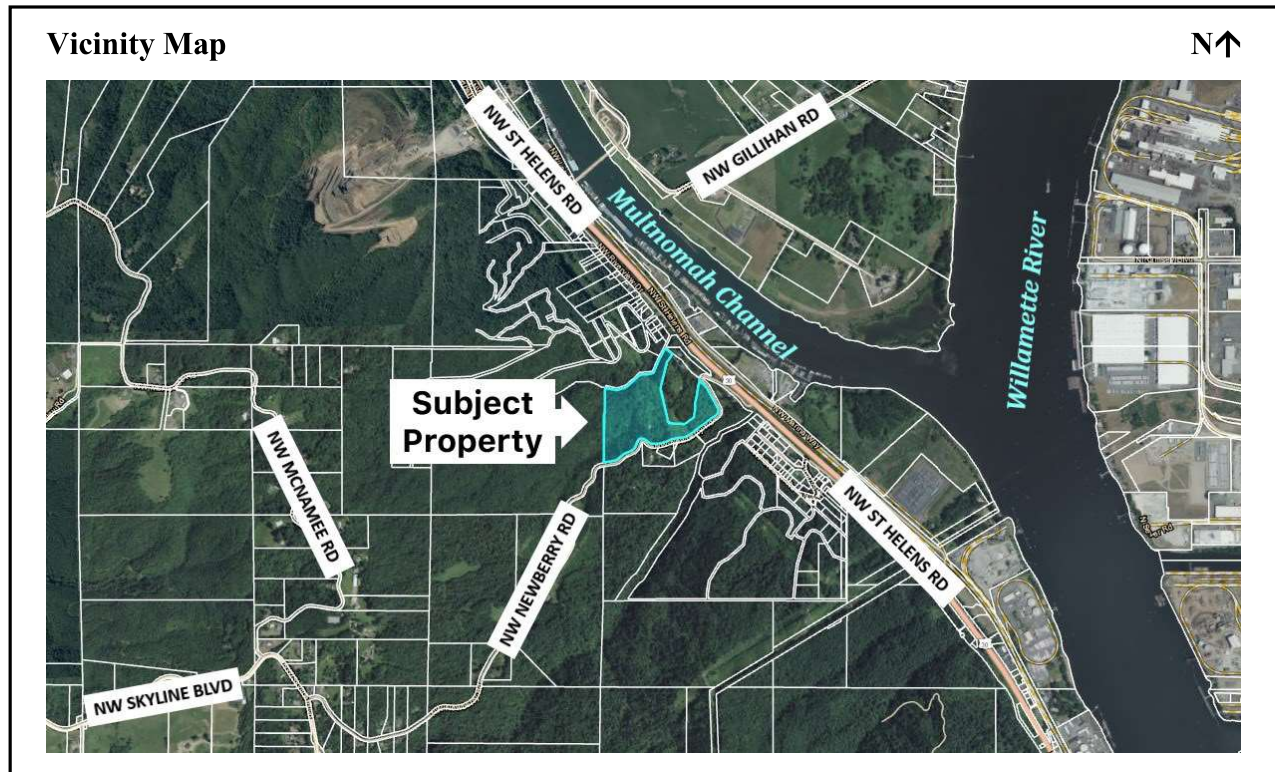

Applicable Approval Criteria:

Multnomah County Code (MCC): General Provisions: MCC 39.1250 Code Compliance and Applications, MCC 39.2000 Definitions, MCC 39.6850 Dark Sky Lighting Standards

Lot of Record: MCC 39.3005 Lot of Record – Generally, MCC 39.3030 Lot of Record – Commercial Forest Use-2 (CFU-2)

Commercial Forest Use Districts (CFU): MCC 39.4070(C) Allowed Uses - Farm use, as defined in ORS 215.203, MCC 39.4070(T) Allowed Uses - Accessory Structures..., MCC 39.4075(B) Review Uses - Template Dwelling..., MCC 39.4090 Template Dwelling Standards, MCC 39.4105 Building Height Requirements, MCC 39.4110 Forest Practices Setbacks and Fire Safety Zones, MCC 39.4115 Development Standards for Dwellings and Structures, MCC 39.4150 Single Family Dwellings Condition of Approval - Prohibition on Claims Alleging Injury from Farm or Forest Practices, MCC 39.4155 Exceptions to Secondary Fire Safety Zones

Copies of the referenced Multnomah County Code sections are available by visiting <https://www.multco.us/landuse/zoning-codes> under the link **Chapter 39: Multnomah County Zoning Code** or by contacting our office at (503) 988-3043.

Conditions of Approval

The conditions listed are necessary to ensure that approval criteria for this land use permit are satisfied. Where a condition relates to a specific approval criterion, the code citation for that criterion follows in parenthesis.

1. **Permit Expiration** – This land use permit shall expire as follows:
 - a. Within **four (4) years** of the date of the final decision for residential development on land zoned for Commercial Forest Use outside of an urban growth boundary when construction has not commenced. [MCC 39.1185(C)]
 - i. For the purposes of 1.a, commencement of construction shall mean actual construction of the foundation or frame of the approved structure, a single-family dwelling.
 - ii. For purposes of 1.a, notification of commencement of construction shall be given to Multnomah County Land Use Planning Division a minimum of seven (7) days prior to the date of commencement. Notification shall be sent via email to LUP-submittals@multco.us with the case no. T2-2025-0035 referenced in the subject line. [MCC 39.1185]
 - b. Within **four (4) years** of the date of commencement of construction when the structure has not been completed. [MCC 39.1185(C)]
 - i. For the purposes of 1.b, completion of the structure shall mean completion of the exterior surface(s) of the structure, a single-family dwelling and compliance with all conditions of approval in the land use approval.
 - ii. For purposes of 1.b, the property owner shall provide building permit status in support of completion of exterior surfaces of the structure and demonstrate compliance with all conditions of approval. The written notification and documentation of compliance with the conditions shall be sent to LUP-submittals@multco.us with case no. T2-2025-0035 referenced in the subject line. [MCC 39.1185]

Note: The property owner may request to extend the timeframe within which this permit is valid, as provided under MCC 39.1195, as applicable. The request for a permit extension must be submitted prior to the expiration of the approval period.

2. Approval of this land use permit is based on the submitted written narrative(s) and plan(s). No work shall occur under this permit other than that which complies with this approval and is consistent with supporting documents. It shall be the responsibility of the property owner(s) to comply with these documents and the limitations of approval described herein. [MCC 39.1170(B)]
3. **Prior to submitting Building Plans for Zoning Review and Conditions of Approval Verification**, the property owner(s) or their representatives shall:
 - a. Acknowledge in writing that they have read and understand the conditions of approval and intend to comply with them. A Letter of Acknowledgement has been provided to assist you. The signed document shall be submitted and uploaded when submitting Building Plans for Zoning Review and Review of Conditions of Approval. [MCC 39.1170(A) & (B)]

- b. Record with the County Recorder a document binding owner and the successors in interest acknowledge the rights of owners of nearby property to conduct forest operations consistent with the Forest Practices Act and Rules, and to conduct accepted farming practices. [MCC 39.4090(A)(8)]
- c. Record with the County Recorder a document binding the landowner, and the landowner's successors in interest, prohibiting them from pursuing a claim for relief or cause of action alleging injury from farming or forest practices for which no action or claim is allowed under ORS 30.936 or 30.937. [MCC 39.4150]
- d. Record with the County Recorder the covenants, conditions and restrictions form adopted as "Exhibit A" to the Oregon Administrative Rules (OAR), Chapter 660, Division 6 (December, 1995), or a similar form approved by the Planning Director:
 - i. The covenants, conditions and restrictions shall specify that:
 - 1. All lots (or parcels) that are part of the tract shall be precluded from all future rights to site a dwelling; and
 - 2. No lot (or parcel) that is part of the tract may be used to qualify another tract for the siting of a dwelling. [MCC 39.4090(A)(9)]
- e. Record a covenant with the County Recorder that states that the owner understands and agrees that the buildings labeled "Exist Barn" ("Barn"), "Pump Building," and "Shed" in Exhibit A.32 cannot be occupied as a dwelling or for any other form of permanent or temporary residential use. [MCC 39.4070(T), MCC 39.4075(L), and MCC 39.8860]
- f. Prepare a new site plan demonstrating compliance with primary and secondary fire safety zones ("PFSZ" and SFSZ") for the dwelling, barn, pump building, and shed. [MCC 39.4110(D)(1) & (2)]
 - i. The PFSZ shall be extended 50 feet down the slope from each building. The total PFSZ shall 80 feet from the building down the slope.
 - ii. The SFSZ shall extend 100 feet from the end of the PFSZ for the dwelling, barn, and shed. No SFSZ is required for the pump building. The PFSZ and SFSZ shall be a total of 180 as measured from the dwelling, barn, and shed down the slope.
- g. Plant a sufficient number of trees on the tract to demonstrate that the tract is reasonably expected to meet Department of Forestry stocking requirements at the time specified in Department of Forestry administrative rules. If a sufficient number of trees cannot be planted, the Assessor shall be notified to determine whether the subject property is being managed as forest land and eligible for forest land designation pursuant to ORS 321.359. [MCC 39.4090(A)(6)]
 - i. A stocking survey report shall be submitted to the County Assessor ("Division of Assessment, Recording, and Taxation") to verify that the minimum stocking requirements have or have not been met by the time required by Department of Forestry rules.
- h. Record pages 1 through 7; Exhibits A.3, A.4, A.5, A.29, A.30, A31, and A.32 (Sheet 2 and 3); and the new site plan as required by Condition of Approval 3.f. of this Notice of Decision with the County Recorder. The Notice of Decision shall run with the land. Proof of recording shall be made prior to the issuance of any permits and shall be filed with the Land Use Planning Division. Recording shall be at the applicant's expense. [MCC 39.1175]

- i. Demonstrate compliance with Significant Wildlife Habitat (SEC-h) and Significant Scenic Views (SEC-v) regulations by obtaining SEC-h and SEC-v permits. [MCC 39.1250 and MCC 39.5510]
- j. Demonstrate compliance with the County’s Ground Disturbance regulations by either obtaining an Erosion and Sediment Control (ESC) permit or a Minimal Impact Project (MIP) permit. [MCC 39.1250 and MCC 39.6210]

4. When submitting Building Plans for Zoning Review and Conditions of Approval

Verification, the property owner(s) or their representatives shall:

- a. Provide a Letter of Acknowledgement, recorded Notice of Decision, other documents as required in Condition 3.a through 3.j. [MCC 39.1170(A) & (B)]
- b. Submit and obtain an Agricultural Building Registration for the barn to ensure compliance with the requirements of MCC 39.4070(C) and MCC 39.4070(T). [MCC 39.1250, MCC 39.4070(C), and MCC 39.4070(T)]
- c. Submit a building plan for the dwelling that demonstrates compliance with applicant’s Narrative and Tualatin Valley Fire and Rescue (TVF&R) requirements. The plan must show a fire sprinkler system meeting Section 903.1.3 (NFPA13D) of the Oregon Fire Code in the dwelling. [MCC 39.4115(B)(1)(e)]
- d. Submit a building plan for the dwelling that demonstrates compliance with the standards of the applicable building code or as prescribed in ORS 446.003 through 446.200 relating to mobile homes. [MCC 39.4115(C)]
- e. Submit plans, including floor plans and building elevations for the shed. [MCC 39.4070(T) & MCC 39.4105]
- f. Submit a building plan for the pump building demonstrating that the building will be constructed or modified in accordance with the International Fire Code Institute Urban-Wildland Interface Code Section 504 Class 1 Ignition Resistant Construction as adopted August, 1996, or as later amended. The property owners shall have the designer or architect certify or stamp the building plan drawings showing that the building meets these standards. [MCC 39.4155(B)(2)]
- g. Submit a final Lighting Plan including cut sheets and specifications showing the location and details for all exterior lighting on the dwelling, barn, pump building, shed, and supporting the subject property. [MCC 39.4115 & MCC 39.6850]
 - i. All exterior lighting shall be a fixture type that is fully shielded with opaque materials and directed downwards.
 - 1. “Fully shielded” means no light is emitted above the horizontal plane located at the lowest point of the fixture’s shielding.
 - 2. Shielding must be permanently attached.

Note: Land Use Planning collects additional fees at the time of submitting Building Plans for Zoning Review and Conditions of Approval Verification review.

5. During construction, the property owner(s) or their representatives shall:

- a. Construct the mobile home, if applicable so the dwelling is attached to a foundation for which a building permit has been obtained. [MCC 39.4115(C)]

- b. Construct the pump building so the building complies with the International Fire Code Institute Urban-Wildland Interface Code Section 504 Class 1 Ignition Resistant Construction as adopted August, 1996, or as later amended. [MCC 39.4155(B)(2)]
 - c. Construct the storm water drainage control system described in Exhibit A.6 and A.7. [MCC 39.4115(E)(2)]
6. **Prior to issuance of the Certification of Occupancy**, the property owner(s) or their representatives shall:
- a. Establish the Primary Fire Safety Zone and the Secondary Fire Safety Zone around the dwelling, barn, pump building, and shed. [MCC 39.4110(D)]
 - b. Demonstrate that the pump building has been constructed in accordance with the International Fire Code Institute Urban-Wildland Interface Code Section 504 Class 1 Ignition Resistant Construction as adopted August, 1996, or as later amended. The property owners shall provide as-built plans stamped and certified by the architect demonstrating that the physical improvements are consistent with the International Fire Code. The as-built plans shall be sent to LUP-submittals@multco.us with case no. T2-2025-0035 referenced in the subject line. [MCC 39.4155(B)(1) & (6)]
7. **As an on-going condition**, the property owner(s) shall:
- a. Be precluded from all future rights to site a new dwelling on the subject property, except as provided for a replacement dwelling. [MCC 39.4090(A)(3)(g)]
 - b. Not alter or install the following features: cooking facilities, toilet, bathing facilities, or closets built into a wall in the barn, pump building, or shed without first obtaining Land Use Planning approval. [MCC 39.4070(T) & MCC 39.4075(L)]
 - c. Not use the barn, pump building, or shed, whether temporarily or permanently, as a primary dwelling, accessory dwelling unit, apartment, guesthouse, housing rental unit, sleeping quarters or any other residential use. A mattress, bed, Murphy bed, cot, or any other similar item designed to aid in sleep as a primary purpose may be stored in the building, if it is disassembled for storage. [MCC 39.4070(T) & MCC 39.4075(L)]
 - d. Maintain the trees, shrubs, and other vegetation on the subject property to meet the PFSZ requirements: Trees within the PFSZ shall be spaced with greater than 15 feet between the crowns. The trees shall also be pruned to remove low branches within 8 feet of the ground as the maturity of the tree and accepted silviculture practices may allow. All other vegetation should be kept less than 2 feet in height. [MCC 39.4110 Table 1, MCC 39.4110(D)(1), and MCC 39.4110(D)(5)]
 - e. Maintain the vegetation on the subject property to meet the SFSZ requirements. The vegetation within the SFSZ shall be pruned and spaced so that fire will not spread between crowns of trees. Small trees and brush growing underneath larger trees should be removed to prevent the spread of fire up into the crowns of the larger trees. [MCC 39.4110 Table 1, MCC 39.4110(D)(2), and MCC 39.4110(D)(5)]
 - f. Not construct combustible fences without first obtaining land use approval for any fence. At no time shall a combustible fence be located within 12 feet of the exterior surface of the pump building. [MCC 39.4155(B)(3)]
 - g. Maintain the stormwater drainage control system for the life of the dwelling in compliance with Exhibit A.6 and A.7. [MCC 39.4115(E)(2)]

- h. Maintain the exterior lighting so that the light source is fully shielded with opaque materials, directed downwards, and the lighting is contained within the boundaries of the Lot of Record on which it is located. [MCC 39.4115 & MCC 39.6850]
 - i. “Fully shielded” means no light is emitted above the horizontal plane located at the lowest point of the fixture’s shielding.
 - ii. Shielding must be permanently attached.

Note: Land Use Planning must sign off on the building plans before you can go to the Building Department. When ready to submit Building Plans for Zoning Review, complete the following steps:

1. Read your land use decision, the conditions of approval and modify your plans, if necessary, to meet any condition that states, “Prior to submitting Building Plans for Zoning Review and Conditions of Approval Verification...” Be ready to demonstrate compliance with the conditions.
2. You will need to provide a copy of your Transportation Planning Review (TPR) sign-off with your building plans. If you have not yet received sign-off, visit the following webpage for instructions on how to request a review of your plans: <https://www.multco.us/planreview>. Failure to obtain TPR sign-off of your plans will result in delaying your zoning review.
3. Contact the City of Portland, Bureau of Development Services, On-site Sanitation at 503-823-6892 or e-mail septic@portlandoregon.gov for information on completing the Septic Permit or Evaluation process for the proposed development. All existing and/or proposed septic system components (including septic tank and drainfield) must be accurately shown on the site plan.
4. Visit <https://www.multco.us/landuse/submitting-building-plan> for instructions regarding the submission of your building plans for zoning review and review of conditions of approval. Please ensure that any items required under, “When submitting Building Plans for Zoning Review and Conditions of Approval Verification ...” are ready for review. Land Use Planning collects additional fees at the time of zoning review.

Once you have obtained an approved zoning review, application for building permits may be made with the City of Portland.

<p>Notice to Mortgagee, Lien Holder, Vendor, or Seller: ORS Chapter 215 requires that if you receive this notice it must be promptly forwarded to the purchaser.</p>

Findings of Fact

FINDINGS: Written findings are contained herein. The Multnomah County Code (MCC) criteria and Comprehensive Plan Policies are in **bold** font. Staff analysis and comments are identified as ‘**Staff:**’ and address the applicable criteria. Staff comments may include a conclusionary statement in *italic*.

1.0 Project Description:

Staff: The applicant requests a Planning Director’s Decision to establish a farm use and agricultural building and New Forest Dwelling, Forest Development Standards, and Exception to the Secondary Fire Safety Zone permits to establish a new single-family dwelling utilizing the template test, accessory buildings, accessory structures (septic system including pipes and drainfield and stormwater drainage control system), and private driveway.

2.0 Property Description & History:

Staff: This application is for 2N1W33A -00600. The subject property is located on the north side of NW Newberry Road in unincorporated west Multnomah County outside of Metro’s Urban Growth Boundary (UGB). The subject property is zoned Commercial Forest Use – 2 (CFU-2) and has four (4) overlays: Geologic Hazards (GH), Significant Wildlife Habitats (SEC-h), Significant Streams (SEC-s), and Significant Scenic Views (SEC-v).

The property is occupied by two (2) buildings that are assessed as “farm buildings” according to the County Assessor. The property is approximately 22.88 acres. The most current aerial photo shows a heavily forested property with one building/structure (Exhibit B.3).

3.0 Public Comment:

Staff: Staff mailed a notice of application and invitation to comment on the proposed application to the required parties pursuant to MCC 39.1105 (Exhibit C.4). Staff did not receive public comments during the 14-day comment period.

4.0 Code Compliance and Applications Criteria:

4.1 § 39.1250 CODE COMPLIANCE AND APPLICATIONS.

Except as provided in subsection (A), the County shall not make a land use decision approving development, including land divisions and property line adjustments, or issue a building permit or zoning review approval of development or any other approvals authorized by this code for any property that is not in full compliance with all applicable provisions of the Multnomah County Zoning Code and/or any permit approvals previously issued by the County.

(A) A permit or other approval, including building permit applications, may be authorized if:

(1) It results in the property coming into full compliance with all applicable provisions of the Multnomah County Zoning Code. This includes sequencing of permits or other approvals as part of a voluntary compliance agreement; or

*** * * * ***

Staff: This standard provides that the County shall not make a land use decision approving development for a property that is not in full compliance with County Code or previously issued

County approvals, except in the following instances: approval will result in the property coming into full compliance, approval is necessary to protect public safety, or the approval is for work related to or within a valid easement.

A finding of satisfaction of this standard does not mean that a property is in full compliance with the Zoning Code and all prior permit approvals (and, accordingly, does not preclude future enforcement actions relating to uses and structures existing at the time the finding is made). Instead, a finding of satisfaction of this standard simply means that there is not substantial evidence in the record affirmatively establishing one or more specific instances of noncompliance.

For purposes of the current application, Staff identified a code compliance issue relating to the construction of two buildings/structures (labeled as “Exist. Barn” and “Shed” in Exhibit A.32) that were not reviewed by the County. Based on aerial photos, it appears that Barn and Shed were built at some point between 1986 and 1990.

Aerial Photo 1986

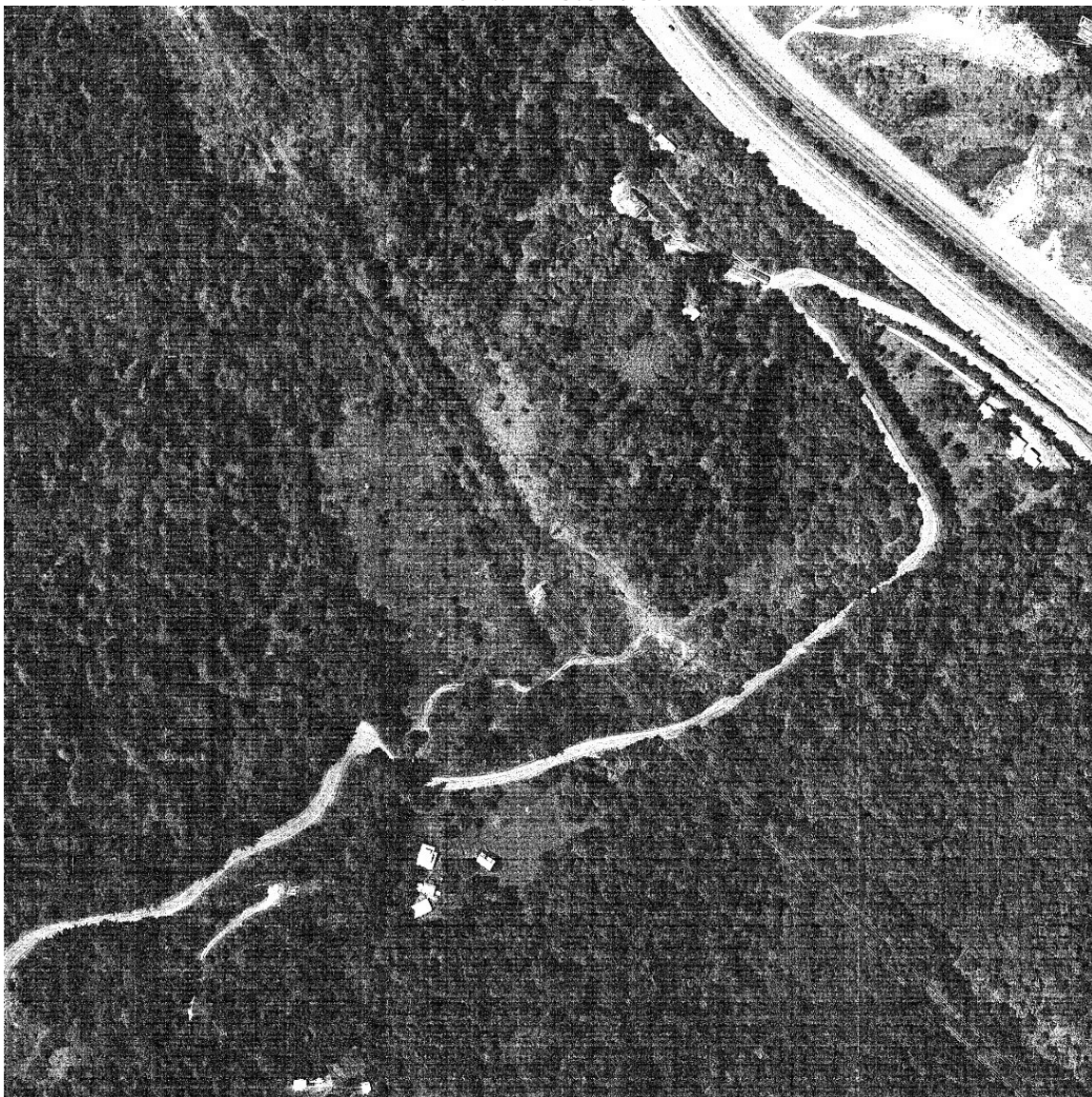

Aerial Photo 1990



Staff described this issue to applicant during a pre-file meeting, PF-2024-0001 on February 1, 2024 (Exhibit B.4).

The applicant responded by submitting this application for review of a Planning Director's Decision, Forest Development Standards, and Exception to the Secondary Fire Safety Zone to establish an agricultural use, an agricultural building, and an accessory building to address the above compliance issues. This application, a Type II application, is the first part of a sequencing of permits needed to resolve the code compliance issues relating to non-permitted development. The second application request that would be required is for Significant Scenic Views (SEC-v), Significant Wildlife Habitats (SEC-h), and either Erosion and Sediment Control (ESC) or Minimal Impact Project (MIP) permits, which are potentially Type I permit requests. In completing the required Conditions of Approval, the applicant will continue towards sequencing of permits to return the subject property into full compliance with Multnomah County Code. *As conditioned, criterion met.*

5.0 Lot of Record Criteria:

5.1 § 39.3005- LOT OF RECORD – GENERALLY.

(A) An area of land is a “Lot of Record” if it meets the standards in Subsection (B) of this Section and meets the standards set forth in this Part for the Zoning District in which the area of land is located.

(B) A Lot of Record is a parcel, lot, or a group thereof that, when created or reconfigured, either satisfied all applicable zoning laws and satisfied all applicable land division laws, or complies with the criteria for the creation of new lots or parcels described in MCC 39.9700. Those laws shall include all required zoning and land division review procedures, decisions, and conditions of approval.

(1) “Satisfied all applicable zoning laws” shall mean: the parcel, lot, or group thereof was created and, if applicable, reconfigured in full compliance with all zoning minimum lot size, dimensional standards, and access requirements.

(2) “Satisfied all applicable land division laws” shall mean the parcel or lot was created:

*** * * * ***

(b) By a deed, or a sales contract dated and signed by the parties to the transaction, that was recorded with the Recording Section of the public office responsible for public records prior to October 19, 1978; or

(c) By a deed, or a sales contract dated and signed by the parties to the transaction, that was in recordable form prior to October 19, 1978; or

*** * * * ***

5.2 § 39.3030 LOT OF RECORD – COMMERCIAL FOREST USE-2 (CFU-2).

(A) In addition to the standards in MCC 39.3005, for the purposes of the CFU-2 district a Lot of Record is either:

*** * * * ***

(B) In this district, significant dates and ordinances applicable for verifying zoning compliance may include, but are not limited to, the following:

*** * * * ***

(C) A Lot of Record which has less than the minimum lot size for new parcels, less than the front lot line minimums required, or which does not meet the access requirements of MCC 39.4135, may be occupied by any allowed use, review use or conditional use when in compliance with the other requirements of this district.

(D) The following shall not be deemed a Lot of Record:

*** * * * ***

Staff: The subject property was previously found to be a Lot of Record in land use case, T2-2022-16204. As the subject property has not been subject to a subsequent boundary reconfiguration since those findings were written, the subject property continues to satisfy all applicable zoning and land division laws. *Criteria met.*

6.0 Commercial Forest Use Districts (CFU) Criteria:

6.1 § 39.4070 ALLOWED USES.

The following uses and their accessory uses are allowed, subject to all applicable supplementary regulations contained in MCC Chapter 39.

* * * * *

6.1.1 (C) Farm use, as defined in ORS 215.203.

Staff: The applicant is requesting a discretionary decision that a Farm Use is occurring on the subject property. As outlined in the Approval Process Table contained in MCC 39.1105, “All Other Discretionary Decisions” are processed as a Planning Director Decision.

As allowed above, a farm use as defined in ORS 215.203 is an allowed use. As defined in ORS 215.203, a farm use is:

“(2)(a) As used in this section, “farm use” means the current employment of land for the primary purpose of obtaining a profit in money by raising, harvesting and selling crops or the feeding, breeding, management and sale of, or the produce of, livestock, poultry, fur-bearing animals or honeybees or for dairying and the sale of dairy products or any other agricultural or horticultural use or animal husbandry or any combination thereof. “Farm use” includes the preparation, storage and disposal by marketing or otherwise of the products or by-products raised on such land for human or animal use. * * *.

(b) As used in this subsection, “current employment” of land for farm use includes:

* * * * *

(C) Land planted in orchards or other perennials, other than land specified in subparagraph (D) of this paragraph, prior to maturity;

* * * * *

To demonstrate that a farm use is occurring on the subject property, the applicant provided a narrative describing the farm use on the property. Currently, the applicant is raising livestock, primarily sheep for wool and hides, and the growing and harvesting of hay and various fruit crops (Exhibit A.35). The Assessor classifies 4.48 acres of the property as being used under farm use land assessment (Exhibit B.1).

To support the farm use on the property, the applicant is seeking to establish a building that was not previously reviewed by the County. The building, labeled as “Exist Barn.” The floor plan shows areas for storage, processing (i.e. cleaning and preparing crops), hay storage, animal pens, and wool/hide processing/storage (Exhibit A.29). To ensure that the building is properly reviewed and permitted, a condition will be required that the agricultural building be registered. *As conditioned, criterion met.*

* * * * *

6.1.2 (T) Accessory Structures subject to the following:

(1) The accessory structure is customarily accessory or incidental to any use permitted or approved in this base zone, is located within 100 feet of the dwelling and is a structure identified in the following list:

* * * * *

(b) Pump houses;

* * * * *

(e) Storage sheds, including shipping containers used for storage only;

* * * * *

(n) Similar structures.

Staff: The applicant is requesting new accessory structures associated with the single-family dwelling. The structures include a septic system (tank, piping, and drainfield) and stormwater drainage control system. Additionally, two structures are buildings, labeled as a “pump building” and “shed” (Exhibit A.32 and A.35). The pump building and shed are listed in the above list; however, the other structures are not. The other structures could be considered as similar structures as they are associated with the single-family dwelling. All the proposed structures can be customarily found and incidental to the primary use of the property, which is a single-family dwelling.

As shown on the site plan, the pump building is more than 100 feet from the dwelling; therefore, will also need to meet the approval criteria in MCC 39.4075(L), which is discussed in Section 6.2.

(2) The Accessory Structure shall not be designed or used, whether temporarily or permanently, as a primary dwelling, accessory dwelling unit, apartment, guesthouse, housing rental unit, sleeping quarters or any other residential use.

(3) The Accessory Structure may contain one sink.

(4) The Accessory Structure shall not contain:

(a) More than one story;

(b) Cooking Facilities;

(c) A toilet;

(d) Bathing facilities such as a shower or bathing tub;

(e) A mattress, bed, Murphy bed, cot, or any other similar item designed to aid in sleep as a primary purpose, unless such item is disassembled for storage; or

(f) A closet built into a wall.

Staff: The plan of the pump building shows a single-story open room with a door (Exhibit A.31). No plans were provided for the shed. A condition will be required that a plan showing the floor plan of the shed be provided during Zoning Plan Review. As proposed and designed, the pump building is not designed temporarily or permanently; as a primary dwelling, accessory dwelling unit, apartment, guesthouse, housing rental unit, sleeping quarters or any other residential use. The plans do not show any of the features above. *As conditioned, criterion met.*

(5) Compliance with MCC 39.8860 is required.

Staff: The applicant is proposing review of accessory buildings; therefore, compliance with MCC 39.8860 is required. A condition of approval has been included requiring recording of the covenant. *As conditioned, criterion met.*

(6) The combined footprints of all Accessory Buildings on a Lot of Record shall not exceed 2,500 square feet.

Staff: As measured on the site plan, the pump building is approximately 130 square feet and the shed is approximately 286 square feet (Exhibit A.32). There are no additional accessory buildings. *Criterion met.*

(7) An Accessory Building exceeding any of the Allowed Use provisions above shall be considered through the Review Use provisions.

Staff: As discussed above, the pump building is more than 100 feet from the dwelling; therefore, the Review Use provisions are applicable. Those provisions are discussed below.

(8) Buildings in conjunction with farm uses as defined in ORS 215.203 are not subject to these provisions. Such buildings shall be used for their allowed farm purposes only and, unless so authorized, shall not be used, whether temporarily or permanently, as a primary dwelling, accessory dwelling unit, apartment, guesthouse, housing rental unit, sleeping quarters or any other residential use.

Staff: The applicant is proposing one building in conjunction with farm uses as defined in ORS 215.203. That building is not subject to the accessory structure provisions above. However, a condition will be required that the building in conjunction with the farm use be only used as described above. *As conditioned, criterion met.*

6.2 § 39.4075 REVIEW USES.

The following uses may be permitted when found by the approval authority to satisfy the applicable standards of this Chapter:

*** * * * ***

6.2.1 (B) The following dwellings:

Base Zone	Template Dwelling -pursuant to MCC 39.4090 and all other applicable criteria.
CFU-2	YES

Staff: The applicant is proposing a new single-family dwelling. A new dwelling can be established using the template dwelling provisions in MCC 39.4090. Those criteria are discussed in Section 6.3. The dwelling is also required to meet Building Height Requirements, Forest Practice Setbacks, Fire Safety Zone requirements, and Development Standards discussed in Section 6.4 through 6.6.

*** * * * ***

6.2.2 (L) Structures or uses customarily accessory or incidental to any use permitted or approved in the CFU, which do not meet the “accessory structures” standard in MCC 39.4070 Allowed Uses, but which meet the following provisions:

- (1) The Accessory Structure shall not be designed or used, whether temporarily or permanently, as a primary dwelling, accessory dwelling unit, apartment, guesthouse, housing rental unit, sleeping quarters or any other residential unit.**
- (2) The Accessory Structure shall not contain a bathing tub.**
- (3) Any toilet or bathing facilities, such as a shower, shall be located on the ground floor of any multi-story building.**
- (4) An Accessory Structure containing a toilet or bathing facilities shall not contain Cooking Facilities.**
- (5) The Accessory Structure shall not contain a mattress, bed, Murphy bed, cot, or any other similar item designed to aid in sleep as a primary purpose, unless such item is disassembled for storage.**

- (6) The applicant must show that building features or combined building footprints exceeding the Allowed Use provisions are the minimum possible departure from the Allowed Use standards to accommodate the use.**
- (7) Compliance with MCC 39.8860 is required.**

Staff: As previously discussed in Section 6.1, the applicant is proposing a new accessory building (Exhibit A.32 and A.35). The accessory building, labeled as a “pump building” exceeds the requirement that the building be located within 100 feet of the dwelling. As previously discussed, the pump building is not designed, whether temporarily or permanently, as a primary dwelling, accessory dwelling unit, apartment, guesthouse, housing rental unit, sleeping quarters or any other residential unit. Additionally, the floor plan shows that it does not contain a bathing tub, cooking facilities, toilet, or a shower bathing facility.

Lastly, a condition will be required to ensure compliance with MCC 39.8860. *As conditioned, criteria met.*

6.3 § 39.4090 TEMPLATE DWELLINGS STANDARDS.

(A) As used in this section, “center of the subject tract” means the mathematical centroid of the tract. A template dwelling may be sited on a tract, subject to the following:

Staff: The applicant has prepared a map showing the center of the subject property. With a 160-acre square centered on the center of the subject property (Exhibit A.14). The map matches the map created by the County (Exhibit B.6). As discussed below, the proposed dwelling must meet the provisions below.

(1) The lot or lots in the tract shall meet the applicable Lot of Record standards of Part 3 of this Chapter.

Staff: As discussed in Section 5.0, the subject property has met the applicable Lot of Record standards of Part 3. *Criterion met.*

(2) The tract shall be of sufficient size to accommodate siting the dwelling in accordance with MCC 39.4110 and 39.4115;

Staff: The subject property is approximately 22.88 acres, which is sufficiently large for the proposed dwelling. The requirements of MCC 39.4110 Forest Practice Setbacks and Fire Safety Zones and MCC 39.4415 Development Standards for Dwellings and Structures are discussed in Section 6.5 and 6.6 below. *Criterion met.*

(3) The tract shall meet the following standards:

* * * * *

(c) If the tract is predominantly composed of soils which are capable of producing above 85 cf/ac/yr of Douglas Fir timber; and

Staff: Using United States Department of Agriculture: Natural Resources Conservation Service – Web Soil Survey Mapper, the subject property is comprised of 17D/17E Goble silt loam, 20F Haplumbrepts, and 37C/37D Quatama loam soils (Exhibit B.7). Goble silt loam can produce between 135-145 cf/ac of Douglas-fir timber and Haplumbrepts 100-125 cf/ac. (Exhibit B.8). Quatama soils are similar in mapping to Cascade, Aloha (Prime Class 1/2 soil), Powell (Prime

Class 1/2 soil), and Latourell (Prime Class 1/2 soil) soils. (Exhibit B.8). As described, Quatama soils are like Cascade silt loam in that they have slow permeability, are a dark brown silt loam about 8-9 inches thick with a subsoil that is dark brown silt loam about 19 inches thick. The site index of Cascade silt loam is 150-165, which translates to a potential yield of 140-164 cf/ac/year.

As the subject property can produce above 85 cf/ac/year of Douglas fir, the proposal application request must meet the provisions below.

1. The lot upon which the dwelling is proposed to be sited and at least all or part of 11 other lawfully created lots existed on January 1, 1993 within a 160-acre square when centered on the center of the subject tract parallel and perpendicular to section lines; and

Staff: The applicant has provided a map showing the 160-acre square template and documentation demonstrating that there are at least 11 lawfully created lots that existed on January 1, 1993 within the template (Exhibit A.14 through A.20).

Staff confirmed that there are more than 11 lawfully created lots that existed on January 1, 1993 and are at least all or partly within the 160-acre square. Many of the lots are in the Armona Subdivision, which contains that contains 34 lots in Blocks 2, 3, 4, 5, 6 and 7 available to count from to meet the requirement above. *Criterion met.*

2. At least five dwellings lawfully existed on January 1, 1993 within the 160-acre square and those dwellings either continue to exist or have been replaced by lawful replacement dwellings.

Staff: The applicant has provided a map showing the 160-acre square template and documentation demonstrating that there are at least five dwellings that lawfully existed on January 1, 1993 (Exhibit A.14 and Exhibits A.21 through A.28).

1. Dwelling 1 on 2N1W33A -01500 was built in 1933 (Exhibit A.21). Aerial photos and Google Street View images show that the dwelling continues to exist (Exhibit A.22).
2. Dwelling 2 and 5 on 2N1W33A -00700 were built in 1895 and 1932. A third dwelling was constructed prior to 1939 was found to exist under land use permit #T2-2015-3906 (Exhibit A.23 and B.11). Aerial photos and Google Street View images show that the dwellings continue to exist (Exhibit A.24).
3. Dwelling 3 on 2N1W33A -00800 was built in 1932 (Exhibit A.25). Aerial photos and Google Street View images show that the dwelling continues to exist (Exhibit A.27).
4. Dwelling 4 on 2N1W28DC -01400 was built in 1941 (Exhibit A.27). Aerial photos and Google Street View images show that the dwelling continues to exist (Exhibit A.28).

Based on the above information, there are six dwellings lawfully existed on January 1, 1993 within the template. *Criterion met.*

(d) Lots and dwellings within urban growth boundaries shall not be counted to satisfy Subsections (a) through (c) above.

Staff: None of the lots or dwelling within the template are located within an Urban Growth Boundary. *Criterion met.*

(e) There is no other dwelling on the tract.

Staff: The subject property does not currently contain a dwelling. *Criterion met.*

(f) No other dwellings are allowed on other lots (or parcels) that make up the tract and deed restrictions established under ORS 215.740(3) for the other lots or parcels that make up the tract are met.

Staff: The subject property is not part of a tract and currently does not contain a dwelling. *Criterion met.*

(g) Except as provided for a replacement dwelling, all lots (or parcels) that are part of the tract shall be precluded from all future rights to site a dwelling.

Staff: A condition will be required to ensure that no other dwellings are allowed on the subject property, except as provided for a replacement dwelling. *As conditioned, criterion met.*

(h) No lot (or parcel) that is part of the tract may be used to qualify another tract for the siting of a dwelling.

Staff: The subject property is not part of a tract. The applicant is requesting to site one single-family dwelling. *Criterion met.*

(i) Pursuant to the definition of “Date of Creation and Existence” in MCC 39.2000, if the lot, parcel or tract does not qualify for a dwelling under the standards in this section, any reconfiguration after November 4, 1993 cannot in any way enable the tract to meet the criteria for a new dwelling.

Staff: As was found in land use case #T2-2022-16204, the Hearings Officer stated in their conclusion:

“Based on the above findings the hearings officer concludes that the land described as “Parcel 1” in the 1985 deed from Miller to Bernet (Exhibit I.2) was a Lot of Record prior to recording of the Looney partition and the roughly 31.57-acre portion of Parcel 1 remaining after recording of the Looney partition, now known as tax lot 600, remains a Lot of Record” (Exhibit B.5).

Based on the above land use case, the date of creation of the subject property is October 30, 1985; therefore, the subject property is eligible for a new forest dwelling through the template test provisions. *Criterion met.*

(j) Pursuant to the definition of “Date of Creation and Existence” in MCC 39.2000, lots, parcels and tracts that are reconfigured after November 4, 1993 cannot be counted as meeting the “other lawfully created lots” existing on January 1, 1993 standard in subsections (A)(3)(a), (b), and (c) of this Section above: 3, 7, and 11 lots respectively.

Staff: No lots created after 1993 are counted in the establishment of the template dwelling area. *Criterion met.*

(k) “Within” as used in the context of Subsections (a)2., (b)2. and (c)2. of this Section shall mean that all of the dwellings or any part of the dwellings are in the 160-acre square.

Staff: All lawful dwellings are located within the 160-acre square. *Criterion met.*

(4) The dwelling will be located outside a big game winter habitat area as defined by the Oregon Department of Fish and Wildlife, or that agency has certified that the impacts of the additional dwelling, considered with approvals of other dwellings in the area since acknowledgment of the Comprehensive Plan in 1980, will be acceptable.

Staff: The dwelling is located outside of Sensitive Big Game Wintering Areas (Exhibit B.9). *Criterion met.*

(5) Proof of a long-term road access use permit or agreement shall be provided if road access to the dwelling is by a road owned and maintained by a private party or by the Oregon Department of Forestry, the Bureau of Land Management, or the United States Forest Service. The road use permit may require the applicant to agree to accept responsibility for road maintenance.

Staff: The subject property abuts NW Newberry Road and does not require any agreements or easements for road access; therefore, this criterion is not applicable. *Criterion not applicable.*

(6) A condition of approval requires the owner of the tract to plant a sufficient number of trees on the tract to demonstrate that the tract is reasonably expected to meet Department of Forestry stocking requirements at the time specified in Department of Forestry administrative rules, provided, however, that:

(a) The planning department shall notify the county assessor of the above condition at the time the dwelling is approved;

(b) The property owner shall submit a stocking survey report to the county assessor and the assessor will verify that the minimum stocking requirements have been met by the time required by Department of Forestry rules. The assessor will inform the Department of Forestry in cases where the property owner has not submitted a stocking survey report or where the survey report indicates that minimum stocking requirements have not been met;

(c) Upon notification by the assessor the Department of Forestry will determine whether the tract meets minimum stocking requirements of the Forest Practices Act. If the department determines that the tract does not meet those requirements, the department will notify the owner and the assessor that the land is not being managed as forest land. The assessor will then remove the forest land designation pursuant to ORS 321.359 and impose the additional tax pursuant to state law;

Staff: A condition will be required that prior to Zoning Plan Review, the subject property be planted with a sufficient number of trees to meet Department of Forestry stocking requirements. If a sufficient number of trees cannot be planted, the Assessor shall be notified to determine whether the subject property is being managed as forest land and eligible for forest land designation pursuant to ORS 321.359. *As conditioned, criterion met.*

(7) The dwelling meets the applicable development standards of MCC 39.4110 and 39.4115;

Staff: As discussed below, the proposed dwelling will need to meet the requirements of MCC 39.4110 Forest Practice Setbacks and Fire Safety Zones and MCC 39.4415 Development Standards for Dwellings and Structures, which are discussed in Section 6.5 and 6.6.

(8) A statement has been recorded with the Division of Records that the owner and the successors in interest acknowledge the rights of owners of nearby property to conduct forest operations consistent with the Forest Practices Act and Rules, and to conduct accepted farming practices;

Staff: A condition will be required that a statement be recorded with the Division of Records as required above. *As conditioned, criterion met.*

(9) Evidence is provided, prior to the issuance of a building permit, that the covenants, conditions and restrictions form adopted as "Exhibit A" to the Oregon Administrative Rules (OAR), Chapter 660, Division 6 (December, 1995), or a similar form approved by the Planning Director, has been recorded with the county Division of Records;

(a) The covenants, conditions and restrictions shall specify that:

1. All lots (or parcels) that are part of the tract shall be precluded from all future rights to site a dwelling; and

2. No lot (or parcel) that is part of the tract may be used to qualify another tract for the siting of a dwelling;

(b) The covenants, conditions and restrictions are irrevocable, unless a statement of release is signed by an authorized representative of Multnomah County. That release may be given if the tract is no longer subject to protection under Statewide Planning Goals for forest or agricultural lands;

(c) Enforcement of the covenants, conditions and restrictions shall be as specified in OAR 660-06-027 (December, 1995).

Staff: A condition will be required that a statement be recorded with the Division of Records as required above. *As conditioned, criterion met.*

6.4 § 39.4105 BUILDING HEIGHT REQUIREMENTS.

(A) Maximum structure height – 35 feet.

(B) Structures such as barns, silos, windmills, antennae, chimneys, or similar structures may exceed the height requirements.

Staff: The elevation plans show the height of the proposed single-family dwelling, pump building, and barn are all less than 35 feet in height (Exhibit A.5 and A.31). No plans were provided for the shed. A condition will be required that a plan showing the elevation of the shed be provided during Zoning Plan Review. *As conditioned, criterion met.*

6.5 § 39.4110 FOREST PRACTICES SETBACKS AND FIRE SAFETY ZONES.

The Forest Practice Setbacks and applicability of the Fire Safety Zones is based upon existing conditions, deviations are allowed through the exception process and the nature and location of the proposed use. The following requirements apply to all structures as specified:

Table 1.

Use	Forest Practice Setbacks			Fire Safety Zones
	Description of use and location	Nonconforming Setbacks	Front Property Line Adjacent to County Maintained Road (feet)	All Other Setbacks (feet)
Template Dwelling	N/A	30	130	Primary & Secondary required
Accessory structures within 100 ft. of the dwelling	N/A	30	30	Primary required
Accessory structures located more than 100 ft. from the dwelling	N/A	30	130	Primary & Secondary required

(A) Reductions to a Forest Practices Setback dimension shall only be allowed pursuant to approval of an adjustment or variance.

Staff: The proposed dwelling, barn, pump building, and shed are required to meet the Forest Practice Setbacks in Table 1 above. The applicant is not requesting a reduction. Further, as discussed below, the required setback of 30 feet is sufficient because the right-of-way width exceeds the minimum required for a rural local road.

The site plan shows that the all structures meet or exceed the minimum of 30 feet from the Front Property Line adjacent to the County maintained road, NW Newberry Road (Exhibit A.32). The site plan also shows that the structures are more than 130 feet from all other property lines.
Criteria met.

(B) Exception to the Secondary Fire Safety Zone shall be pursuant to MCC 39.4155 only. No reduction is permitted for a required Primary Fire Safety Zone through a nonconforming, adjustment or variance process.

Staff: The applicant is requesting an Exception to the Secondary Fire Safety Zone (SFSZ). Those criteria are discussed below in Section 6.8.

(C) The minimum forest practices setback requirement shall be increased where the setback abuts a street having insufficient right-of-way width to serve the area. The county Road Official shall determine the necessary right-of-way widths based upon the county “Design and Construction Manual” and the Planning Director shall determine any additional setback requirements in consultation with the Road Official.

Staff: The right-of-way (ROW) adjacent to the subject property is NW Newberry Road. The road is classified as a rural local road. A rural local road requires a ROW width of 50 feet. NW Newberry Road is 60 feet in width, so no additional right-of way width is needed and the yard does not need to be increased (Exhibit B.2).

(D) Fire Safety Zones on the Subject Tract.

(1) Primary Fire Safety Zone.

(a) A primary fire safety zone is a fire break extending a minimum of 30 feet in all directions around a dwelling or structure. Trees within this safety zone shall be spaced with greater than 15 feet between the crowns. The trees shall also be pruned to remove low branches within 8 feet of the ground as the maturity of the tree and accepted silviculture practices may allow. All other vegetation should be kept less than 2 feet in height.

(b) On lands with 10 percent or greater slope the primary fire safety zone shall be extended farther down the slope from a dwelling or structure as follows:

Percent Slope	Distance In Feet
Less than 10	No additional required
Less than 20	50 additional
Less than 25	75 additional
Less than 40	100 additional

(c) The building site must have a slope less than 40 percent.

Staff: The proposed dwelling, barn, pump building, and shed are required to have a primary fire safety zone (“PFSZ”) in Table 1 above. As measured on the site plan, the proposed dwelling, barn, shed, and pump building are in sloped areas of approximately 12% to 15%. As the slope is less than 20%, the PFSZ must be extended by an additional 50 feet on the downslope (Exhibit A.32 and B.10). A condition will be required that a new site plan be provided showing the correct PFSZ. Additionally, a second condition requires on-going FSZ vegetation maintenance. *As conditioned, criteria met.*

(2) Secondary Fire Safety Zone.

A secondary fire safety zone is a fire break extending a minimum of 100 feet in all directions around the primary safety zone. The goal of this safety zone is to reduce fuels so that the overall intensity of any wildfire is lessened. Vegetation should be pruned and spaced so that fire will not spread between crowns of trees. Small trees and brush growing underneath larger trees should be removed to prevent the spread of fire up into the crowns of the larger trees. Assistance with planning forestry practices which meet these objectives may be obtained from the State of Oregon Department of Forestry or the local Rural Fire Protection District. The secondary fire safety zone required for any dwelling or structure may be reduced under the provisions of MCC 39.4155.

Staff: As required by Table 1, a secondary fire safety zone (“SFSZ”) is required for the proposed dwelling and pump building. As the barn and shed are within 100 feet of the proposed dwelling, no SFSZ is required. As shown on the site plans, there is sufficient area for the SFSZ on the property for the proposed dwelling after extending the PFSZ an addition 50 feet as discussed previously (Exhibit A.32). However, there is insufficient area on the property as required by Table 1 for the pump building. The applicant has requested that the SFSZ be reduced pursuant to the

provisions of MCC 39.4155, which is discussed in Section 6.8. A condition will be required that a new site plan be provided showing the correct SFSZ for the dwelling. A condition requires on-going vegetation maintenance for the SFSZ. *As conditioned, these criteria are met.*

(3) No requirement in (1) or (2) above may restrict or contradict a forest management plan approved by the State of Oregon Department of Forestry pursuant to the State Forest Practice Rules; and

Staff: The applicant has not indicated that the subject property is subject to a forest management plan and the Oregon Department of Forestry Forest Activity Electronic Notification and Reporting System (FERNS) does not show that a Forest management Plan is active; therefore, this criterion is not applicable. *Criteria met.*

(4) Required Primary and Secondary Fire Safety Zones shall be established within the subject tract as required by Table 1 above.

Staff: As previously discussed, there is enough area for the PFSZ as modified (Exhibit A.32). The applicant is requesting an Exception to the SFSZ, which is discussed in Section 6.8. *Criterion met.*

(5) Required Primary and Secondary Fire Safety Zones shall be maintained by the property owner in compliance with the above criteria listed under (1) and (2).

Staff: A condition requires compliance with (5) above for the PSFZ. A SFSZ is not required. *As conditioned, criterion met.*

6.6 § 39.4115 DEVELOPMENT STANDARDS FOR DWELLINGS AND STRUCTURES.

All dwellings and structures shall comply with the approval criteria in (B) through (E) below except as provided in (A). All exterior lighting shall comply with MCC 39.6850:

Staff: As required, all dwelling and structures will need to comply with the approval criteria below. Further, the applicant has not included a lighting plan or samples/technical specifications for the exterior lighting. A condition will be required that when submitting building plans for zoning review, a finalized exterior lighting plan be provided for all exterior lighting on the subject property with technical specifications of the lighting demonstrating compliance with MCC 39.4115(A) and MCC 39.6850. *As conditioned, criterion met.*

* * * * *

(B) New dwellings shall meet the following standards in (1) and (3) or (2) and (3); restored or replacement dwellings greater than 100-feet from an existing dwelling, and accessory buildings (or similar structures) greater than 100-feet from the existing dwelling shall meet the following standards in (1) and (3) or (2) and (3):

Staff: Based on the location of the dwelling and structures (barn, shed, pump building, septic system with drainfield, and stormwater drainage system), the proposal will need to meet the standards in (1) and (3) as discussed below.

(1) The structure shall satisfy the following requirements:

(a) To meet the Forest Practices Setback, the structure shall be located a minimum of 30-feet from a front property line adjacent to a county maintained road and 130-feet from all other property lines;

Staff: The dwelling and structures (barn, shed, pump building, septic system with drainfield, and stormwater drainage system) are located a minimum of 30 feet from the front property line adjacent to the NW Newberry Road, a County maintained road (Exhibit A.32). The dwelling, barn, shed, and pump building are also more than 130 feet from all other property lines. The septic system with drainfield, and stormwater drainage system are either low to the ground or underground; therefore, do not need to meet setback requirements. *Criterion met.*

(b) The structure shall be located in a cleared area of at least 10,000 square feet that meets the tree spacing standards of a primary fire safety zone;

Staff: As measured on the site plan, the dwelling, accessory buildings, and stormwater drainage control system are clustered in a cleared area. The septic system drainfield will need to be in an area that will be cleared. The drainfield will be approximately 7,000 square feet in area (Exhibit A.32). *Criterion met.*

(c) The entirety of the development site is less than 30,000 square feet in total cleared area, not including the driveway;

Staff: As measured on the site plan, the development not including the driveway is approximately 25,000 square feet in area (Exhibit A.32). *Criterion met.*

(d) The structure is sited within 300-feet of frontage on a public road and the driveway from the public road to the structure is a maximum of 500-feet in length;

Staff: The structures are all sited within 300 feet of frontage of NW Newberry Road, a public road (Exhibit A.32). The private driveway is also less than 500 feet in length. *Criterion met.*

(e) The local Fire Protection District verifies that their fire apparatus are able to reach the structure using the proposed driveway; or

Staff: A Fire Service Agency Review Form was reviewed by Jeff Galvan, Fire Inspector Senior Specialist, Portland Fire & Rescue. The review stated, “The proposed development is in compliance with the fire apparatus access standards of the Oregon Fire Code standards as implanted by our Provider” (Exhibit A.11). Further, the review stated:

“The existing fire-flow & flow duration available from public water lines or private well is not adequate to serve the proposed non-commercial structure in compliance with the Oregon Fire Code. The following mitigation measures are necessary* and must be installed prior to occupancy or use of the structure.

* * * * *

Class A or non-combustible roof materials must be installed.

Defensible space of 30 feet around the structure/building/addition.

A fire sprinkler system meeting Section 903.1.3 (NFPA13D) of the Oregon Fire Code shall be installed.”

As required, conditions of approval will be required for the above. *As conditioned, criterion met.*

* * * * *

(3) The risks associated with wildfire are minimized. Provisions for reducing such risk shall include:

- (a) Access roadways shall be approved, developed and maintained in accordance with the requirements of the structural fire service provider that serves the property. Where no structural fire service provider provides fire protection service, the access roadway shall meet the Oregon Fire Code requirements for fire apparatus access;**
- (b) Access for a pumping fire truck to within 15 feet of any perennial water source of 4,000 gallons or more within 100 feet of the driveway or road on the lot. The access shall meet the fire apparatus access standards of the Oregon Fire Code with permanent signs posted along the access route to indicate the location of the emergency water source;**

Staff: As previously discussed, Portland Fire & Rescue has reviewed the access roadways. The review stated, “The proposed development is in compliance with the fire apparatus access standards of the Oregon Fire Code standards as implanted by our Provider” (Exhibit A.11). The site plan shows one fire department turn around will be constructed (Exhibit A.32). *Criteria met.*

(C) The dwelling or structure shall:

- (1) Comply with the standards of the applicable building code or as prescribed in ORS 446.003 through 446.200 relating to mobile homes;**

Staff: The floor plan indicates that the dwelling will be a doublewide manufactured dwelling, which is a type of mobile home (Exhibit A.3). A condition will be required that the manufactured dwelling comply with the applicable building code or as prescribed in ORS 446. *As conditioned, criterion met.*

- (2) If a mobile home, have a minimum floor area of 600 square feet and be attached to a foundation for which a building permit has been obtained;**

Staff: The floor plan indicates that the dwelling will be approximately 1,404 square feet (Exhibit A.3). A condition will be required that the manufactured dwelling be attached to a foundation as part of a building permit authorization. *As conditioned, criterion met.*

- (3) Have a fire retardant roof; and**

Staff: The technical specifications of the “Halsey: West Ridge Doublewide Series” manufactured dwelling indicate that the roof will have Class “A” Fire Rated Architectural Shingles. *Criterion met.*

- (4) Have a spark arrester on each chimney.**

Staff: The floor plan indicates that the dwelling will not have a fireplace or chimney; therefore, this criterion is not applicable. *Criterion not applicable.*

(D) The applicant shall provide evidence that the domestic water supply is from a source authorized in accordance with the Department of Water Resources Oregon Administrative Rules for the appropriation of ground water (OAR 690, Division 10) or surface water (OAR 690, Division 20) and not from a Class 1 stream as defined in the Forest Practices Rules.

* * * * *

(2) Evidence of a domestic water supply means:

* * * * *

(b) A water use permit issued by the Water Resources Department for the use described in the application; or

Staff: The subject property obtains water via a well. Originally drilled in 1992, the State of Oregon Water Well Report #MULT 3209 indicates that the well produces 25 gallons/minute (Exhibit A.12). The site plan shows the well is located south of the proposed dwelling (Exhibit A.32). *Criterion met.*

(E) On-site sewage disposal, storm water/drainage control, water systems unless these services are provided by public or community source, shall be provided on the Lot of Record.

(1) Sewage and stormwater disposal systems for existing development may be off-site in easement areas reserved for that purpose.

(2) Stormwater/drainage control systems are required for new impervious surfaces. The system shall be adequate to ensure that the rate of runoff from the lot for the 10 year 24-hour storm event is no greater than that before the development.

Staff: The applicant has provided a Site Evaluation Report, Septic Review Certification, and Stormwater Drainage Control Certificate. The Site Evaluation Report was drafted by Erin Mick, REHS on September 20, 2012. The Report stated, “this site is suitable for the use of a standard septic tank and drainfield disposal system” (Exhibit A.10). Subsequently, the Septic Review Certification was reviewed Nicole Blais, Multnomah County Sanitarian. The Sanitarian stated, “Proposed 2-bedroom dwelling with new septic system pose no concern to septic.” (Exhibit A.33).

The storm water/drainage control was reviewed and certified by John Middleton, P.E. The Certificate recommends, “Use of gutter, downspout, and splash block drainage control system” (Exhibit A.6 and A.7). The plan shows that rain from the roof will drain to the north into a storm discharge outlet made of 4” rip-rap. This system will ensure that the rate of runoff from the subject property during a 10-year/24-hour storm event is no greater than that before the development. A condition will require that the system be construct as designed and maintain for the life of the dwelling as described.

Lastly, the subject property obtains water via a well. Originally drilled in 1992, the State of Oregon Water Well Report #MULT 3209 indicates that the well produces 25 gallons/minute (Exhibit A.12). The site plan shows the well is located south of the proposed dwelling (Exhibit A.32). *As conditioned, criteria met.*

6.7 § 39.4150 SINGLE FAMILY DWELLINGS CONDITION OF APPROVAL - PROHIBITION ON CLAIMS ALLEGING INJURY FROM FARM OR FOREST PRACTICES.

As a condition of approval of a single family dwelling, the landowner for the dwelling shall sign and record in the deed records for the county a document binding the landowner, and

the landowner's successors in interest, prohibiting them from pursuing a claim for relief or cause of action alleging injury from farming or forest practices for which no action or claim is allowed under ORS 30.936 or 30.937.

Staff: A condition will be required that a document be recorded in the deed records of the County as required above. *As conditioned, criterion met.*

6.8 § 39.4155 EXCEPTIONS TO SECONDARY FIRE SAFETY ZONES.

(A) The secondary fire safety zone for dwellings and structures may be reduced pursuant to the provisions of MCC 39.4155 (B) when:

Staff: The applicant is seeking to reduce the secondary fire safety zone for a structure, a pump building.” The pump building is located too close to the road to allow for enough space to accommodate the 100-foot SFSZ (Exhibit A.32). To be eligible for an exception to the SFSZ, the tract or structure must demonstrate it meets one of the requirements below.

* * * * *

(2) The dwelling or structure will be located within 130 feet of the centerline of a public or private road serving two or more properties including the subject site; or

Staff: The pump building is located within 130 feet from the centerline of a public road serving the property (Exhibit A.32). Therefore, the pump building is eligible for an exception to the SFSZ as discussed below.

* * * * *

(B) Exceptions to secondary fire safety zones shall only be granted upon satisfaction of the following standards:

* * * * *

(2) If the proposed secondary fire safety zone is less than fifty feet, the dwelling or structure shall be constructed in accordance with the International Fire Code Institute Urban-Wildland Interface Code Section 504 Class 1 Ignition Resistant Construction as adopted August, 1996, or as later amended, and

Staff: The pump building does not have a SFSZ. As the pump building has a SFSZ of less than fifty feet, a condition requires that the structure be constructed in accordance with International Fire Code Institute Urban-Wildland Interface Code Section 504 Class 1 Ignition Resistant Construction as adopted August, 1996, or as later amended. A second condition will be required that plans be provided showing the pump building meets this standard prior to obtaining all necessary permits through the City of Portland Permitting & Development (PP&D). *As conditioned, criterion met.*

(3) There shall be no combustible fences within 12 feet of the exterior surface of the dwelling or structure; and

Staff: The site plan shows that there are no combustible fences within 12 feet of the exterior surface of the pump building (Exhibit A.32). An on-going condition requires compliance with this criterion. *As conditioned, criterion met.*

(4) A dwelling shall have a central station monitored alarm system if the secondary fire safety zone equivalents of subsection (B) (1) above are utilized, or

Staff: The exception is for the pump building. The pump building is not a dwelling; therefore, this criterion is not applicable. *Criterion not applicable.*

(5) A dwelling shall have a central station monitored 13D sprinkler system if the secondary fire safety zone equivalents of subsection (B) (2) above are utilized. Expansions of existing single family dwellings as allowed by MCC 39.4075 (A) shall not be required to meet this standard, but shall satisfy the standard of MCC 39.4115(C)(3) and (E).

Staff: The exception is for the pump building. The pump building is not a dwelling; therefore, this criterion is not applicable. *Criterion not applicable.*

(6) All accessory structures within the fire safety zone setbacks required by MCC 39.4110, and all accessory structures within 50 feet of a dwelling, shall have a central monitored alarm system.

Staff: The pump building is not within the fire safety zone setbacks of the other buildings and is more than 50 feet from the dwelling (Exhibit A.32). Therefore, this criterion is not applicable. *Criterion not applicable.*

(7) All accessory structures within 50 feet of a building shall have exterior walls constructed with materials approved for a minimum of one-hour-rated fire-resistive construction, heavy timber, log wall construction or constructed with noncombustible materials on the exterior side.

Staff: The pump building is not within 50 feet of building (Exhibit A.32). Therefore, this criterion is not applicable. *Criterion not applicable.*

(8) When a detached accessory structure is proposed to be located so that the structure or any portion thereof projects over a descending slope surface greater than 10 percent, the area below the structure shall have all underfloor areas enclosed to within 6 inches of the ground, with exterior wall construction in accordance with Section 504.5 of the International Fire Code Institute Urban-Wildland Interface Code Class 1 Ignition Resistant Construction as adopted August, 1996, or as later amended, or underfloor protection in accordance with Section 504.6 of that same publication. Exception: The enclosure may be omitted where the underside of all exposed floors and all exposed structural columns, beams and supporting walls are protected as required for exterior one-hour-rated fire-resistive construction or heavy-timber construction.

Staff: The pump building is not located over a descending slope surface greater than 10 percent; therefore, this criterion is not applicable. *Criterion not applicable.*

7.0 Conclusion

Based on the findings and other information provided above, the applicant has carried the burden in the Commercial Forest Use – 2 (CFU-2) zone necessary for:

1. A Planning Director’s Decision to establish a farm use and;
2. New Forest Dwelling, Forest Development Standards, and Exception to the Secondary Fire Safety Zone to establish a new single-family dwelling utilizing the template test, accessory buildings, accessory structures (septic system including pipes and drainfield and stormwater drainage control system), and private driveway.

This approval is subject to the conditions of approval established in this report.

8.0 Exhibits

‘A’ Applicant’s Exhibits

‘B’ Staff Exhibits

‘C’ Procedural Exhibits

Exhibits with an ‘*’ have been reduced in size and included with the mailed decision. All exhibits are available for digital review by sending a request to LUP-comments@multco.us.

Exhibit #	# of Pages	Description of Exhibit	Date Received / Submitted
A.1	2	Application Form	07/08/2025
A.2	33	Narrative	07/08/2025
A.3*	1	Floor Plan	07/08/2025
A.4*	1	Sheet SP-1: Fire Sprinkler Plan	07/08/2025
A.5*	1	Exterior Elevation Plan	07/08/2025
A.6	4	Stormwater Drainage Control Certificate prepared by John Middleton, Oregon Registered Professional Engineer	07/08/2025
A.7	1	Storm Water Plan	07/08/2025
A.8	1	Sewage Discharge Line Plan	07/08/2025
A.9	1	Septic Drainfield System Detail Plan	07/08/2025
A.10	1	City of Portland – Bureau of Development Services: On-site Sanitation Site Evaluation Report #12-173202-SE / Land Feasibility Study #22-12	07/08/2025
A.11	2	Fire Service Agency Review	07/08/2025
A.12	1	State of Oregon Water Well Report	07/08/2025
A.13	2	Transportation Compatibility Memo	07/08/2025
A.14	1	Map showing the Template	07/08/2025

A.15	4	<p>Ticor Title Company Parcel Information:</p> <ul style="list-style-type: none"> ▪ 2N1W28DC -01500 (Property ID #R108982) ▪ Statutory Warrant Deed recorded as Instrument #2020-111679 on August 1, 2020 ▪ Assessor Map ▪ Full Assessor Map 	07/08/2025
A.16	8	<p>Revised Ticor Title Company Parcel Information:</p> <ul style="list-style-type: none"> ▪ 2N1W28DC -01500 (Property ID #R108982) ▪ Statutory Warrant Deed recorded as Instrument #2020-111679 on August 1, 2020 ▪ Assessor Map ▪ Full Assessor Map ▪ Aerial Map ▪ Flood Map – 100 Year ▪ Soil Map ▪ Zoning Map 	07/08/2025
A.17	5	<p>Ticor Title Company Parcel Information:</p> <ul style="list-style-type: none"> ▪ 2N1W28DC -01600 (Property ID #R108984) ▪ Assessor Map ▪ Full Assessor Map ▪ Aerial Map ▪ Statutory Warrant Deed recorded as Instrument #2020-111679 on August 1, 2020 	07/08/2025
A.18	10	<p>Revised Ticor Title Company Parcel Information:</p> <ul style="list-style-type: none"> ▪ 2N1W28DC -01600 (Property ID #R108984) ▪ Assessor Map ▪ Full Assessor Map ▪ Aerial Map ▪ Flood Map – 100 Year ▪ Soil Map ▪ Zoning Map ▪ Statutory Warrant Deed recorded as Instrument #2020-111679 on August 1, 2020 ▪ Assessment and Taxation Property Information for 2N1W28DC -01600 (Alt Acct #R038501240 / Property ID #R108984) 	07/08/2025

A.19	10	<p>Revised Ticor Title Company Parcel Information:</p> <ul style="list-style-type: none"> ▪ 2N1W33A -00600 (Property ID #R325446) ▪ Warrant Deed recorded as Instrument #2011-138576 on December 09, 2011 ▪ Oregon Department of Human Resources Certificate of Death for Christine Ann Lightcap ▪ Assessor Map ▪ Full Assessor Map ▪ Aerial Map ▪ Flood Map – 100 Year ▪ Soil Map ▪ Zoning Map 	07/08/2025
A.20	12	<p>Revised Ticor Title Company Parcel Information:</p> <ul style="list-style-type: none"> ▪ 2N1W33A -00700 (Property ID #R325444) ▪ Bargain and Sale Deed recorded as Instrument #2021-175813 on December 06, 2021 ▪ Bargain and Sale Deed recorded as Instrument #2020-114277 on September 08, 2020 ▪ Assessor Map ▪ Full Assessor Map ▪ Aerial Map ▪ Flood Map – 100 Year ▪ Soil Map ▪ Zoning Map 	07/08/2025
A.21	5	PortlandMaps: 13220 NW Newbery Road	07/08/2025
A.22	3	Google Maps Street View: 13220 NW Newbery Road	07/08/2025
A.23	5	PortlandMaps: 12941 NW Newbery Road	07/08/2025
A.24	1	PortlandMaps Snapshot: 12941 NW Newbery Road	07/08/2025
A.25	5	PortlandMaps: 12928 NW Newbery Road	07/08/2025
A.26	1	Google Maps Street View: 12928 NW Newbery Road	07/08/2025
A.27	5	PortlandMaps: 13510 NW Riverview Drive	07/08/2025
A.28	1	Assessment and Taxation Property Information for 2N1W33A -00600 (Alt Acct #R971330150 / Property ID #R325446)	07/08/2025
A.29*	3	Floor Plan for Barn	07/08/2025
A.30*	1	Elevation Plan for Barn	12/29/2025
A.31*	1	Well House Building Elevation	12/29/2025
A.32*	3	<p>Revised Site Plans</p> <ul style="list-style-type: none"> ▪ Sheet 1: Storm Water Plan ▪ Sheet 2: Sewage Discharge Line ▪ Sheet 3: Septic Drainfield System Detail 	12/29/2025
A.33	9	Septic Review Certification	12/29/2025

A.34	2	Revised Application Form	01/02/2026
A.35	33	Revised Narrative	01/02/2026
'B'	#	Staff Exhibits	Date
B.1	2	Assessment and Taxation Property Information for 2N1W33A-00600 (Alt Acct #R971330150 / Property ID #R325446)	07/08/2025
B.2	1	Current Tax Map for 2N1W33A	07/08/2025
B.3	2	Aerial Photo taken on August 9, 2025	07/08/2025
B.4	16	Pre-file meeting conference notes, PF-2024-0001	07/08/2025
B.5	9	Notice of Decision for land use case no. T2-2022-16204	07/08/2025
B.6	1	Map showing the 160-acre template	07/08/2025
B.7	3	United States Department of Agriculture: Natural Resources Conservation Service – Web Soil Survey	05/14/2026
B.8	1	Productivity Ratings and Classifications for Douglas Fir Yields	05/14/2026
B.9	1	Map showing Sensitive Big Game Winter Habitat Areas	05/14/2026
B.10	1	Metro Map map showing the contours of the property	05/18/2026
B.11	11	Notice of Decision for land use case #T2-2015-3906	05/29/2026
'C'	#	Administration & Procedures	Date
C.1	8	Incomplete letter	08/06/2025
C.2	1	Applicant's acceptance of 180-day clock	09/03/2025
C.3	2	Complete letter (day 1) sent on February 11, 2026	01/03/2026
C.4	14	Opportunity to Comment	03/10/2026
C.5	1	Extension of the 150-Day Deadline Request	04/22/2026
C.6	19	Short Decision	06/09/2026
C.7	43	Decision	06/09/2026

Halsey

West Ridge Doublewide Series

1,354 SQ. FT. (Approximate) 2 Bedroom, 2 Bath



Last Updated: 11-10-20

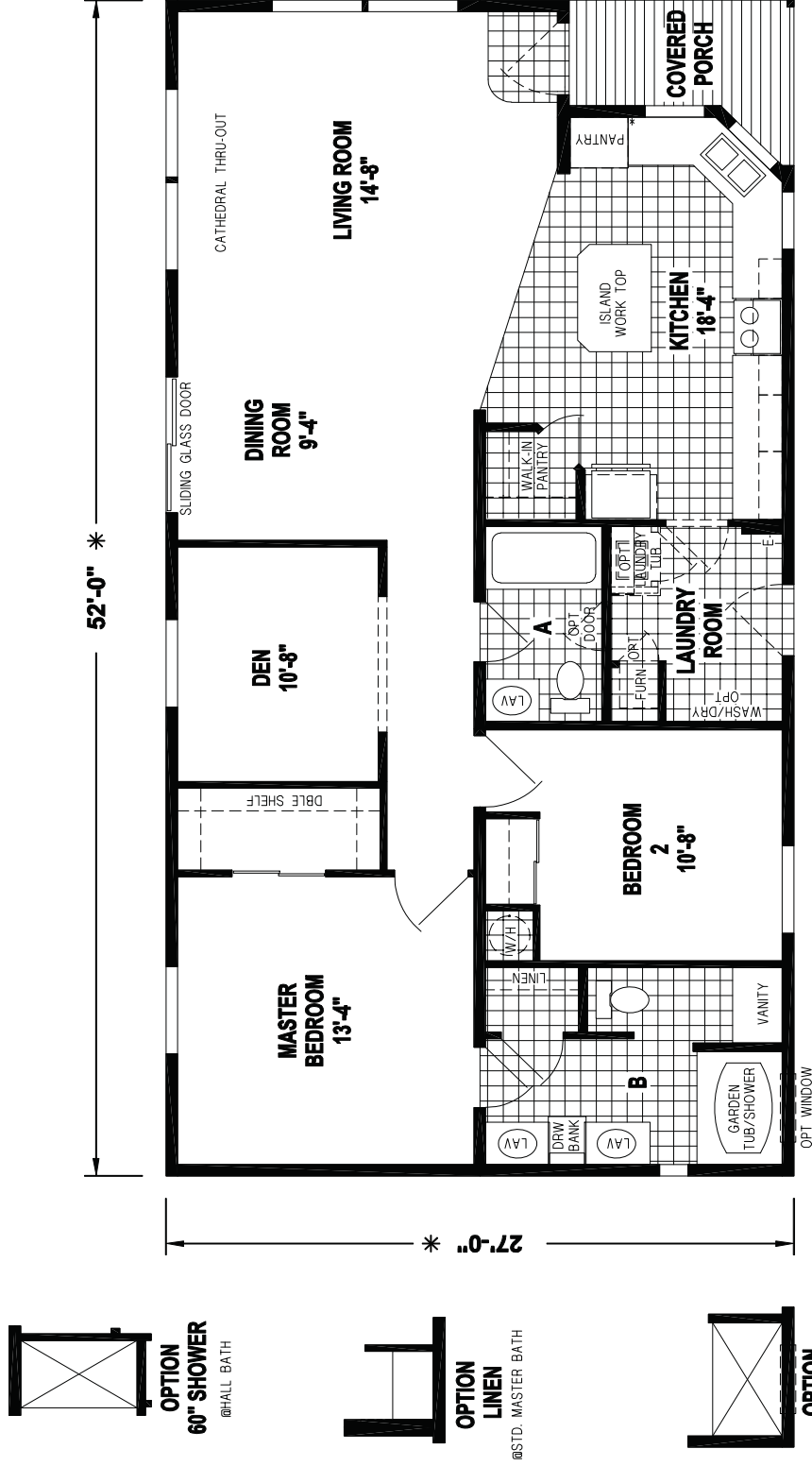

FACTORY EXPO HOME CENTERS
550 Booth Bend Rd.
McMinnville, OR 97128

NorthWestFactoryDirectHomes.com | 1-800-645-4943

IMPORTANT: Alta Cima Corp reserves the right to modify, cancel or substitute products or features of this event at any time without prior notice or obligation. Pictures and other promotional materials are representative and may depict or contain floor plans, square footages, elevations, options, upgrades, extra design features, decorations, floor coverings, specialty light fixtures, custom paint and wall coverings, window treatments, landscaping, sound and alarm systems, furnishings, appliances, and other designer/decorator features and amenities that are not included as part of the home and/or may not be available at all locations. Home, pricing and community information is subject to change, and homes to prior sale, at any time without notice or obligation. ©2020 Alta Cima Corp. All rights reserved.

MANUFACTURED BY:



I authorize Factory Expo Home Centers to build my house, per this plan.

X _____
Customer Signature/Date

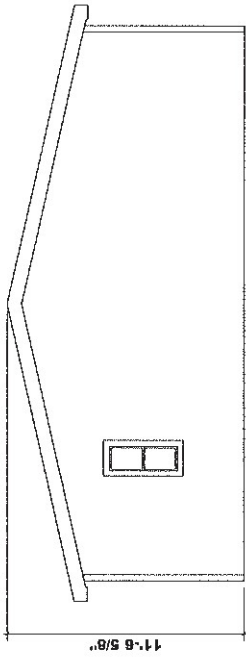

FRONT ENDWALL ELEVATION

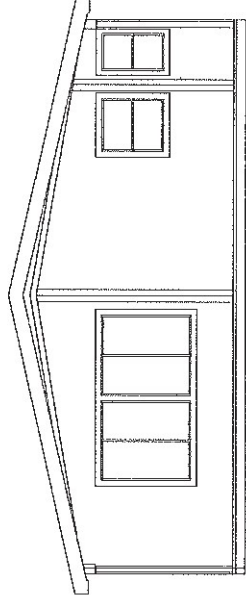

REAR ENDWALL ELEVATION

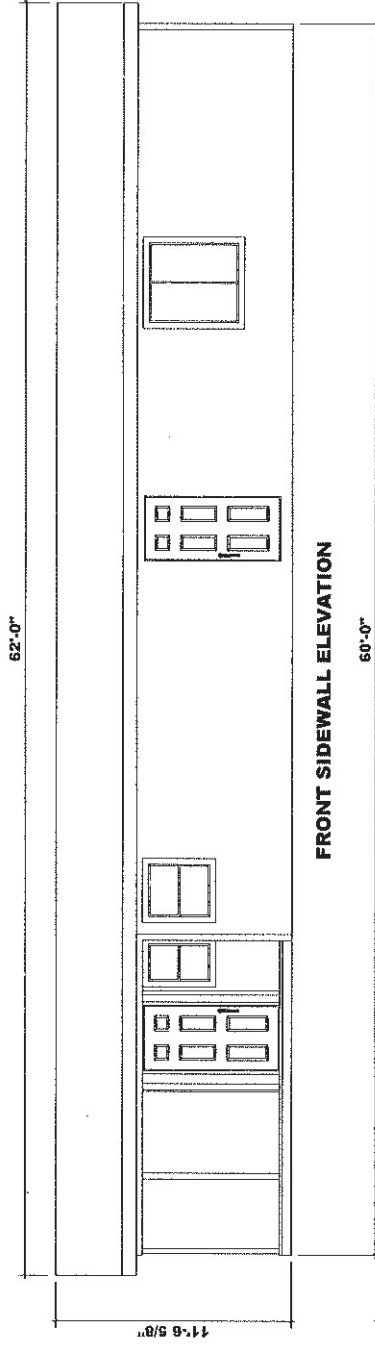

FRONT SIDEWALL ELEVATION

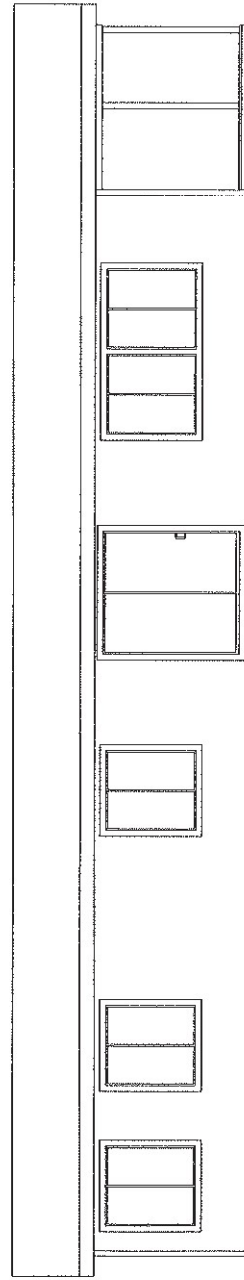

REAR SIDEWALL ELEVATION

SKYLINE
 HOMETTE CORPORATION (503) 472-3181, FAX (503) 472-6463

Division 591, 550 S. Booth Bend Rd.
 McMinnville, OR 97128-9314

DRAWING TITLE
EXTERIOR ELEVATION

ORIGINAL DRAWING BY:
 E. COLVIN

PRODUCT
 WEST RIDGE

6" WALLS

1,355 SQ. FT.

DATE
 03-11-2011

REVISIONS
 SHEET 2-A
 MODEL NO. 1218-CT

GROUND FLOOR BARN

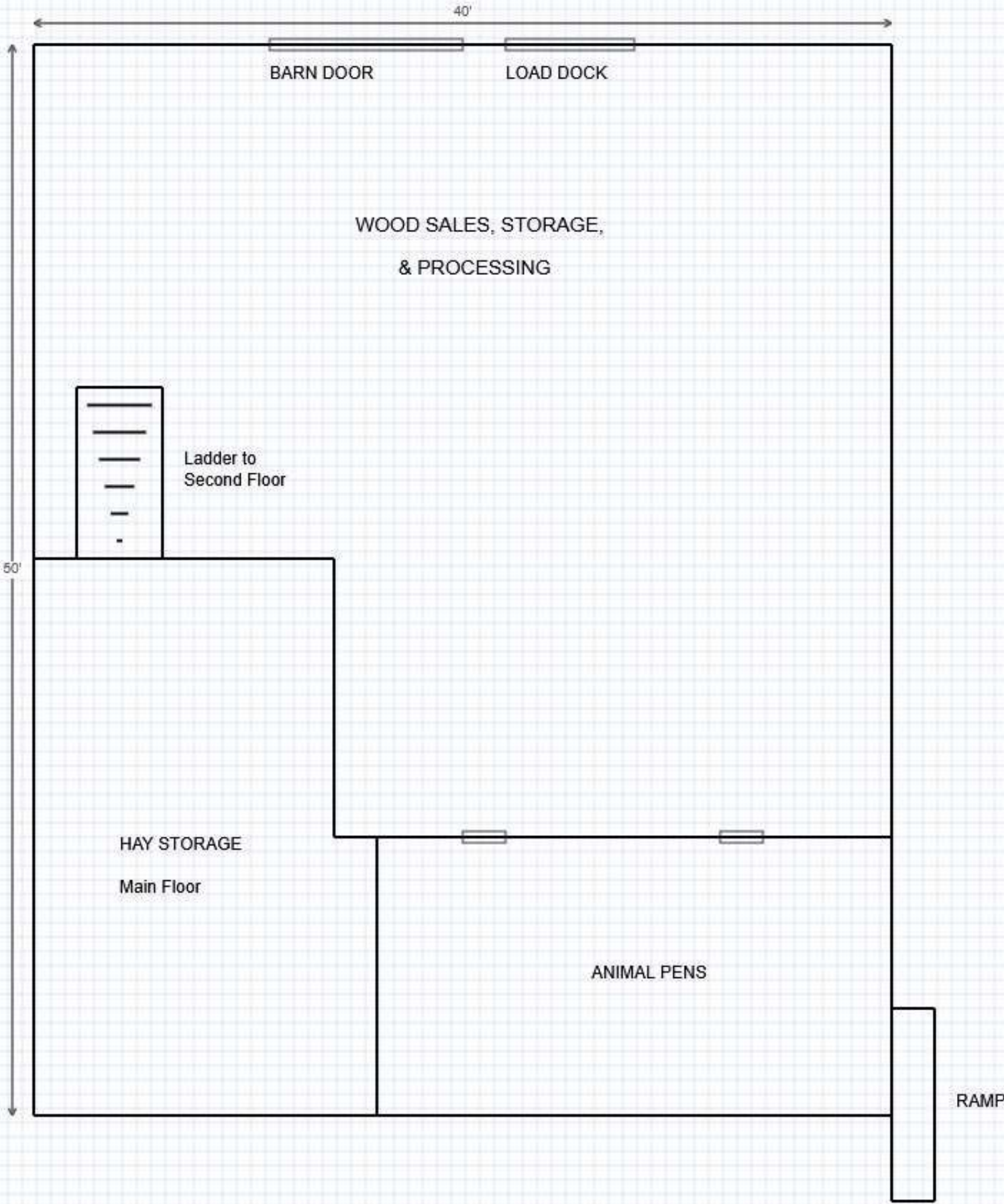

SECOND FLOOR

40'

OPEN TO
BELOW

Ladder to Main Floor

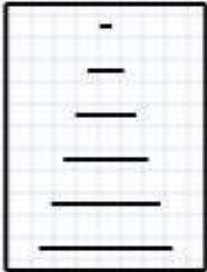

Stairs to Third Level

50'

THIRD FLOOR

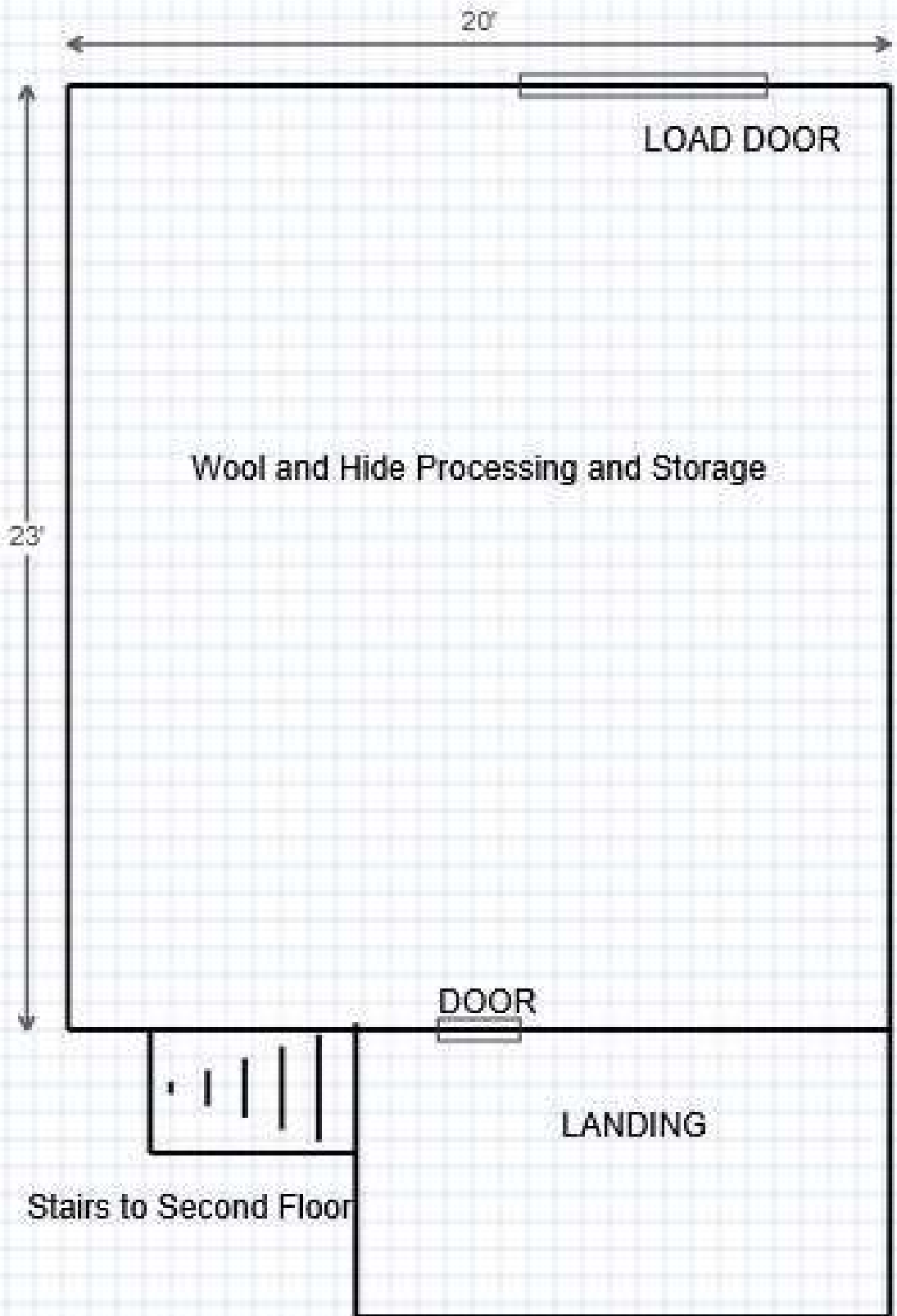

Barn Elevations

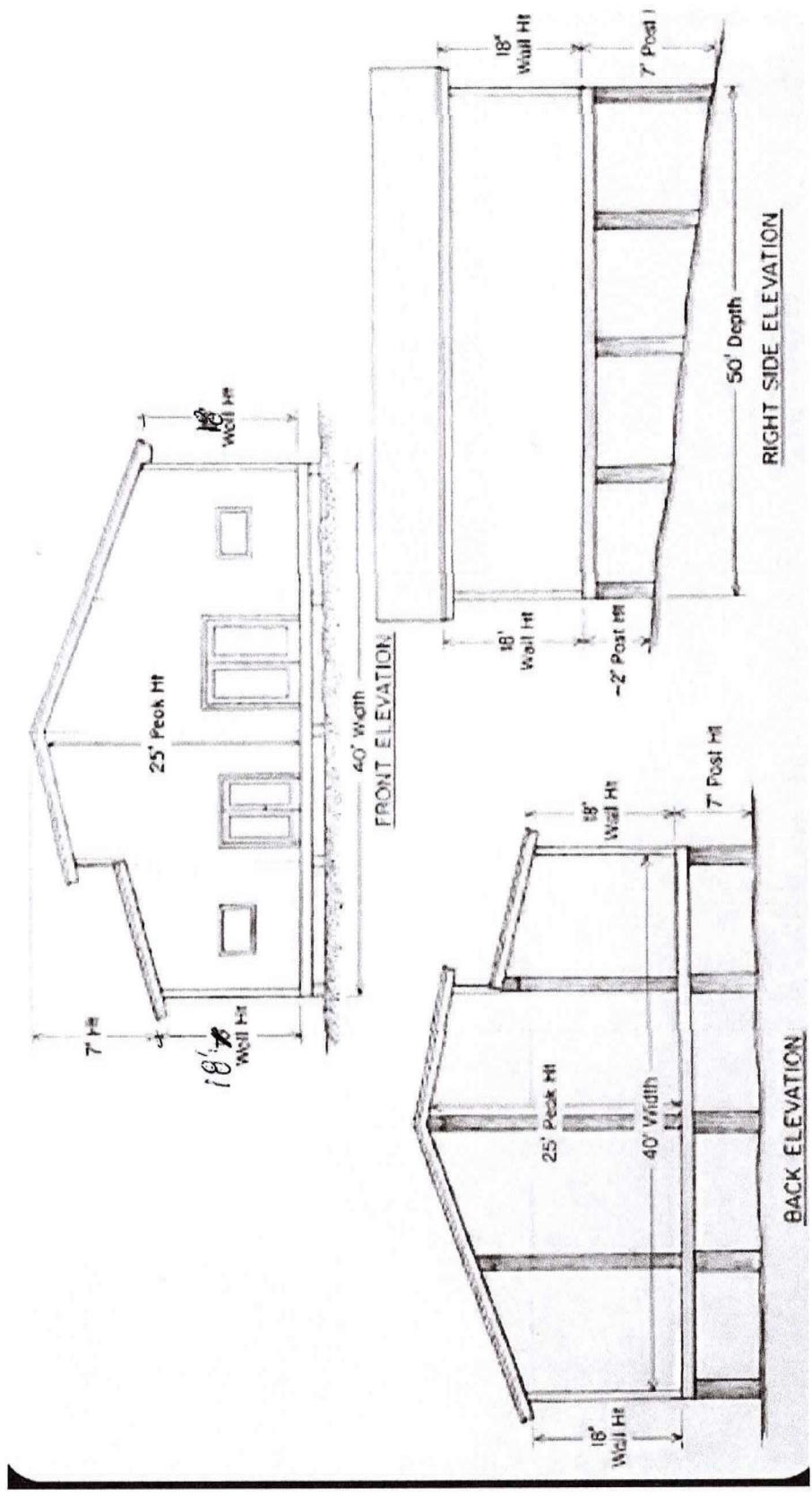

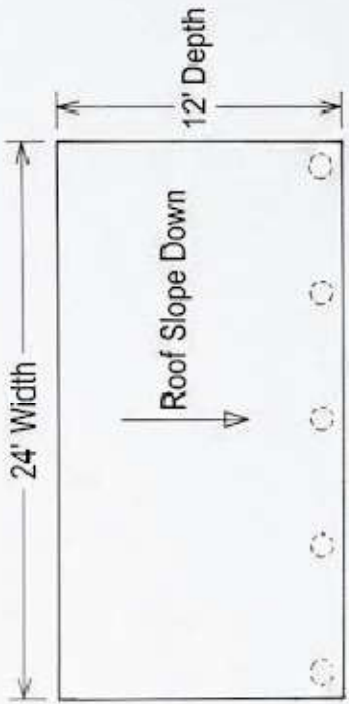

TOP PLAN

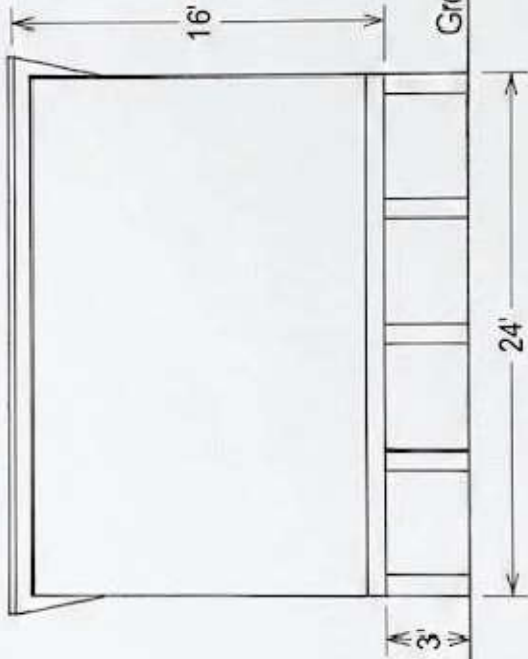

FRONT ELEVATION

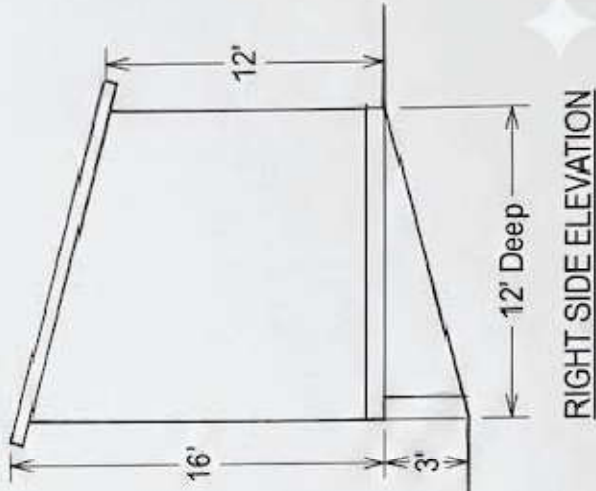

RIGHT SIDE ELEVATION

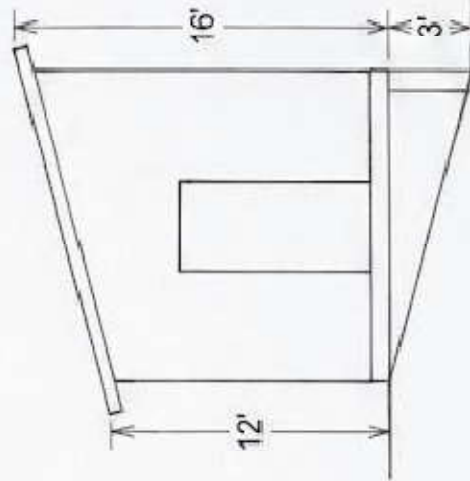

LEFT SIDE ELEVATION

